

A11100 985721

NAT'L INST OF STANDARDS & TECH R.I.C.



A11100985721

Rubin, Arthur I/Building for people : be  
QC100 .U57 V474:1980 C.1 NBS-PUB-C 1980

PUBLICATIONS

# BUILDING FOR PEOPLE

BEHAVIORAL RESEARCH  
APPROACHES AND DIRECTIONS

U.S. DEPARTMENT OF COMMERCE National Bureau of Standards SP 474











# BUILDING FOR PEOPLE

## Behavioral Research Approaches and Directions

*Special publication*

Arthur I. Rubin  
Jacqueline Elder

Environmental Design Research Division  
Center for Building Technology  
National Engineering Laboratory  
National Bureau of Standards  
Washington, DC 20234



U.S. DEPARTMENT OF COMMERCE  
Philip M. Klutznick, Secretary  
Luther H. Hodges, Jr., Deputy Secretary  
Jordan J. Baruch, Assistant Secretary  
for Productivity, Technology and Innovation

NATIONAL BUREAU OF STANDARDS  
Ernest Ambler, Director

Issued June 1980

NATIONAL BUREAU  
OF STANDARDS  
LIBRARY

APR 17 1981  
191350

QC100  
.U57  
no. 474  
1980  
J.2

Library of Congress Catalog Card Number: 80-600065

**National Bureau of Standards Special Publication 474**

Nat. Bur. Stand. (U.S.), Spec. Publ. 474, 315 pages (June 1980)

CODEN: XNBSAV

U.S. GOVERNMENT PRINTING OFFICE

WASHINGTON: 1980

☆ U.S. GOVERNMENT PRINTING OFFICE : 1980 O-328-025

---

For sale by the Superintendent of Documents, U.S. Government Printing Office  
Washington, D.C. 20402 - Price \$14

(Add 25 percent for other than U.S. mailing)

## **Dedication**

To Paul Reece Achenbach; an engineer who designed and created a research environment which nurtured and fostered the growth of a new discipline.

## **Acknowledgements**

We owe our thanks to many people who have helped us complete this work. The following people provided detailed critiques of the entire manuscript: Dr. Galen Crazz, John Christian, John Eberhard, Ben Handler, John Holton, Dr. Gerald Howett, Stephen Kliment, Lars Lerup, Dr. Joseph Murdoch, George Renaud, Roger Rensberger, Dr. Stuart Robinson, Edward Russell, Robert Tibbott, and George Turner. Dr. Joan Rosenblatt assisted us by a detailed review of the statistics chapter. NBS photographers Chuck Sabadezas and Richard Seek took many of the photographs which appear in the publication. We are also grateful for the permission of HUD, NASA, EPA, the AIA Journal, and several individuals for permitting the use of their photographs.

The book's illustrations and graphs were prepared by Judy Cox. Tim White and Stephen Kliment were instrumental in developing architectural ideas which lent themselves to illustration.

We are appreciative of the many hours of work spent typing and revising this work to make it ready for publication by Sharon Farinholt, Susan Johnson, and Miriam Oland.

Finally, we are grateful for the painstaking efforts of Becky Morehouse, Reeves Tilley, Betty Burris, Charles Messina, and Gail Minning, who helped ease this work through the publication process.



# Abstract

---

The primary goal of this report is to acquaint the practicing architect and the architectural student with the potential contributions of the social sciences to the solution of building design problems.

The report is divided into seven major parts, each part containing several chapters.

Part I explores problems connected with today's buildings and advocates a design approach based on a team concept including architects, behavioral researchers, and engineers.

Part II takes up the scientific approach to research, stressing the need for employing experimental controls and systematic procedures to collect objective data.

Parts III, IV, and V describe methods employed by researchers to collect Man/Environment (M/E) data. The emphasis is on the need to develop systematic procedures to collect information, because only in this way can significant progress be made in developing a discipline of M/E studies.

Part VI summarizes the major points and indicates approaches and directions for developing such a discipline.

Part VII contains reference information to broaden the perspective of the reader with respect to M/E issues.

The final part of the work contains a glossary, bibliographic information, and an index.

Key words: Architecture; audition; built environment; color; environmental psychology; illumination; perception; questionnaires; research methodology; sensory environment; social sciences; thermal environment.

# Preface

This work is designed as a response to increasing demands that buildings meet the needs of those who occupy them. If this is to come about, the architect must have easy-to-use, practical information on how buildings and people influence one another. This is known as the study of Man/Environment (M/E) relationships. It is not a novel idea. Investigations to date have been made on a piecemeal basis, however, and have been conducted largely to respond to particular design problems. Such an approach is costly, time-consuming, and finally, ineffective. What is needed is an effort to improve the discipline of M/E studies so that information is made available to all building designers. This way, incremental improvements to available information can be used to build upon (and verify) the work of colleagues; and the architect can apply findings as they are disseminated.

In the past decade, behavioral researchers and architects have found they have much in common. Each profession has faced the need to explain the ways in which people respond to their environments. The architect must know how people respond to various kinds of buildings and communities. The interests of behavioral researchers and architects coincide when recommendations for design criteria and guidelines (e.g., appropriate lighting and noise levels) are decided.

Architects and behavioral researchers have worked together before but with limited success. One reason is that the professions are at odds as to how to develop the required information. Behavioral researchers rely on the scientific method—controlled procedures based largely on analytic techniques. Architects rely heavily on intuition to synthesize available information into a design solution. Moreover, behavioral researchers are trained to be skeptical users of information (questioning its adequacy and relevance); the architect is more likely to rely on the advice of expert consultants.

To develop the needed information and to make sure it is properly applied, the social scientist and the architect should work together. The design process offers one framework for joint efforts. It provides the opportunity to see where building users are affected by design decisions, thereby showing what, and when, information is needed. Finally, the design process should allow for evaluation of buildings after completion—i.e., to determine if user-related design goals were achieved and indeed, whether they were appropriate. Such a feedback loop will also provide information to the building community as a whole.

## Assumptions

This work is based on a number of premises:

- The present state of M/E studies is unsatisfactory.
- The study of user requirements in buildings will soon constitute a major research activity.
- Architects do not understand enough about the research process in general and social science studies in particular.
- The training of architects will stress behavioral research in the future more than to date.
- The trend toward design by team rather than by an individual architect will grow.
- Professional and market forces will demand that the design team include social scientists.

## Purpose

A primary goal of this work is to show the practicing architect and the architectural student how the social sciences can improve solutions to building design problems. Answers already exist to many current problems. Of greater importance, however, is the need for social scientists to work with architects to develop better building user data. The development of a M/E discipline will result in standardized procedures to make observations and measurements of phenomena dealing with the relationships of people and buildings. One of the greatest shortcomings in M/E research today is the lack of agreement among professionals concerning what to measure and how measurements should be made.

This work points to the need for carefully controlled procedures (the scientific method) to obtain M/E information. A broad range of research methods is described and critiqued. The discussion is designed to provide an insight into the working style of a researcher in order to smooth the path for interdisciplinary work. Since the amount of available material is enormous, this study can do no more than sample the information. To encourage a search for further information, a bibliography is included in the appendix, as is background information on selected topics.

Finally, we have reviewed past joint efforts and suggested a number of future directions.



## Limitations and Potential Biases

Research should not be expected to provide clear-cut solutions to M/E problems. The impact of the environment on man is not well known. Environmental influences may vary with building types, activity, experience, and other social and design factors. Research should be performed to produce better information on all these issues, thereby providing greater understanding.

This work does *not* contain design recommendations. It is not meant to be a handbook of information for the architect. Rather, this study is focused on the *need* for this information.

All of us, whether researchers or designers, bring our assumptions and value judgments to our work. The authors of this report are no exception. Instead of ignoring them, however, we will try to make them as explicit as possible.

Undoubtedly, the major influence on our research outlook came from our training and experience in applying industrial and experimental psychological techniques to problems. This background (which we consider to be synonymous with human factors) was the primary filter through which we viewed and evaluated the material covered in this work.

Another major orientation is that of psychophysics, which emphasizes the collection of data in at least two realms (physical and psychological; psychological and physiological; physiological and physical)—at least one of which permits quantitative observations. Without this link between behavior and the physical world of the architect, any discussion of the relationships between behavior and the environment is academic for the most part.

## Structure and Organization

The work is divided into seven major parts—each containing several chapters. Since one of the major purposes is to tell architects about research approaches that apply to M/E studies, we have not avoided redundant presentations of research methodologies as they apply to different problems. Rather, we have made a conscious effort to suggest the versatility of particular approaches to solve different problems.

*Part I (Chapters 1-3)* explores problems with today's buildings and advocates a design approach based on a team concept including architects, engineers, and behavioral researchers. Attention is on improving working relationships. A M/E scientific discipline is advocated as a means of systematically developing the information needed for more responsive buildings.

*Part II (Chapters 4-6)* provides an overview of the scientific approach to research, stressing the need for experimental controls and systematic procedures to collect objective data. Experimental methodology is discussed as the means of making controlled observations and measurements. User requirements are touched upon by defining what we mean by "users" and "requirements" in M/E research. Finally, research approaches are used to introduce research techniques that solve problems dealing with building user interactions.

*Parts III, IV, and V (Chapters 7-17)* provide an overview of the methods employed by researchers to collect M/E data. Emphasis is on the need to develop procedures to collect information. Only by developing such standardized approaches is progress possible in upgrading M/E information in an orderly way. Detailed studies were selected for general applicability, novelty, and presentation of a broad range of approaches.

*Part VI (Chapter 18)* summarizes the major points covered in the work and points to approaches and directions for developing a M/E discipline.

*Part VII (Chapters 19-21)* contains reference information to broaden the perspective of the reader with respect to M/E issues. Unlike the earlier chapters, these chapters address broad areas which cut across particular research methodology concerns.

The final part of the work contains a glossary, bibliographic information, and an index.

The authors hope this work will serve to sharpen the concern of architects and other designers to the needs of the users who occupy the buildings they create.



# Contents

<b>Part I. Problem Definition and Research Directions</b> .....	1
Chapter 1. Introduction .....	3
Chapter 2. Background .....	9
Chapter 3. Design/Behavioral Research Bridges .....	23
<b>Part II. Research Approach and Identification of Subject Areas</b> .....	37
Chapter 4. Scientific Approach .....	39
Chapter 5. Man/Environment Research .....	53
Chapter 6. Scales of Observation .....	69
<b>Part III. Man/Environment Research—Components and Characteristics</b> .....	81
Chapter 7. Man .....	83
Chapter 8. Man/Environment Interactions .....	99
Chapter 9. The Man-Made Environment .....	113
<b>Part IV. Well-Known Senses—Hearing, Vision</b> ..	125
Chapter 10. The Auditory Environment .....	127
Chapter 11. Visual Perception .....	143
Chapter 12. The Visual Environment—Illumination .....	151
Chapter 13. Color .....	167
<b>Part V. Less Explored Senses</b> .....	183
Chapter 14. The Thermal Environment .....	185
Chapter 15. The Olfactory Environment—Air Quality .....	197
Chapter 16. Environmental Stability—Movements .....	203
Chapter 17. The Cutaneous Environment—Skin Senses ...	211
<b>Part VI. Summary</b> .....	221
Chapter 18. Summary, Conclusions, and Directions .....	221
<b>Part VII. Reference Material</b> .....	229
Chapter 19. Behavioral Research—Historical Factors (Overview) .....	231
Chapter 20. Surveys .....	253
Chapter 21. Classification, Measurement, and Statistics ..	263
Glossary .....	275
Bibliography .....	289
Index .....	303







# Part I

---

## Problem Definition and Research Directions

Many members of the building community are dissatisfied with the quality of buildings. While several possible reasons for the problem were suggested, the underlying cause seems to be the poor quality of M/E information available to architects. An orderly approach to obtain such information must be developed—one based on scientific procedures using the combined resources and know-how of the human sciences and the architectural profession. In short, a discipline of M/E studies is needed.

What is needed for a M/E discipline?

Three important attributes of any discipline are:

- A common set of research methods to develop required information.
- A defined subject area which describes the problems to be studied.
- Theoretical models.

This part of the present study will examine the state-of-the-art of M/E information and provide an overview of a process designed to overcome the problems described.

Chapter 1 describes the status of information dealing with the relationship of design factors and the behavior of people in buildings. It notes that better data are needed and should be developed by cooperative efforts of architects and behavioral researchers.

Chapter 2 provides an overview of the state-of-the-art of defining user requirements. Design by team is suggested as the approach needed to ensure that buildings are responsive to their occupants.

Chapter 3 points to a number of systems analytic approaches available to facilitate the development of effective cooperation between architects and behavioral researchers.





*A Modern Skyline (HUD)*



## Introduction

Where Are We Now?

What Changes Are Needed?

Strengthening Existing Links

Developing New Links

Goal of This Work—Better Understanding Between Professions

Compatibility of Science and Design

Improving Building User Information



*Visual Pollution (EPA Documerica)*

In recent years a kind of consensus has emerged that many buildings do not properly serve the functions for which they were designed. Architects, builders, engineers, administrators of governmental and private institutions, and the general public are among those who question many of the results of current building practices. This criticism is not limited to buildings in the United States; it is a worldwide phenomenon.

Buildings are said to be made for people. Yet, ironically, those who actually occupy or otherwise use buildings are seldom able to influence the way buildings are designed. Rather, nearly all the important decisions are based on factors that have little to do with either the way people use buildings or the way buildings affect people. Those decisions are made by clients, builders, architects, and others who in most instances do not occupy the buildings which are ultimately constructed. This lack of user participation has been cited as a major reason for dissatisfaction. Yet these same users can serve as valuable sources of information in the design and evaluation phases of the building cycle.

## Where Are We Now?

Building design today is a product of two often conflicting traditions—architecture and engineering.

Sigfried Giedion offers one insight into the source of conflict:

*We have behind us a period in which thinking and feeling were separated. . . Contemporary artists and scientists have lost contact with each other, they speak the language of their time in their own work, but they cannot even understand it as it is expressed in work of a different character.<sup>1</sup>*

Buildings therefore reflect the work of: (1) architects who want to make a personal statement and, in so doing, apply engineering technology which they do not always thoroughly integrate and (2) engineers who are technically oriented and not sensitive enough to the needs of building occupants.

The training and experience of both the architect and the engineer have led to the viewpoint (common also to other disciplines) that problems are solved by applying the technical know-how of their profession. Each therefore sees himself as an expert with little need to draw upon the experience of others even when making major decisions.

They do rely on others for support, however. For example, an architect will retain an acoustician to obtain a satisfactory auditory environment. But, whenever acoustical factors

should shape the building, architectural rather than acoustical factors tend to predominate. Similarly, an architect will rely on a structural engineer to insure the safety and structural integrity of a building, but often will reject suggestions that modify its overall appearance.

User requirements in the past have for the most part been defined by the personal experiences of architects and their clients. There has been little incentive to spend time and resources defining the requirements of building occupants.

The rare studies of occupant requirements have met with mixed success. Architects and social scientists have been uneasy collaborators in their attempts to work together on design problems. Where interdisciplinary work has been successful, research findings have been too specific to a particular design problem to benefit the design profession as a whole. Consequently, the development and application of user information is at best haphazard and unsystematic.

## What Changes Are Needed?

We need to upgrade the quality and importance of user information employed in the design process. If buildings are to serve the people who occupy them, we must learn more about the way in which the built environment affects behavior and about how behavioral factors should influence building design.

Building evaluation criteria should include long-term occupancy and

operational needs, not only visual attributes. Uniform procedures are necessary to monitor and assess long-term building performance, including a feedback system. The information should then be disseminated to every architect. The need for new information should be identified during evaluation and, in due course, developed.

Building design today requires a team approach. The post-World War II information explosion has made it impossible for one person to master the many activities which comprise building design. Architectural and engineering firms increasingly use interdisciplinary teams. This trend can be expected to accelerate as the building design process becomes more complex in response to internal and external influence from the building community. More specifically, a close working relationship is needed between architects (who apply behavioral information) and social scientists (who develop and interpret it) if buildings are to better serve their occupants.

Architects should become familiar with behavioral science information applicable to building users. Familiarity with this information will enable them to make better use of available design data dealing with user needs and to identify requirements for new and/or improved information. Social scientists in turn should pay greater attention to building user problems which require better behavioral information for their solution. Such a dialog between the two professions could achieve agree-

ment on informational requirements and priorities. Together with engineers and other related professionals, plans could then be formulated to develop the information.

This call for better user information is neither new nor likely to cause much controversy. Many architects, critics, researchers, and building users have already expressed this point of view.

Walter Gropius described the design problem as follows:

*A new language of vision is slowly replacing individualistic terms like 'taste' or 'feeling' with terms of objective validity. Based on biological facts—both physical and psychological—it seeks to represent the impersonal cumulative experience of successive generations. Here roots true tradition. We are able today to feed the creative instinct of a designer with richer knowledge of the relation of solids and voids in space, of light and shade, of color and scale, objective factors instead of arbitrary, subjective interpretation of formulas long since stale.*

*The designer must learn to see; he must know the effects of optical illusions, the psychological influence of shapes, colors and textures, the effects of contrast, direction, tension and repose; and he must learn to grasp the significance of the human scale. Vague phrases like 'the atmosphere of a building' or the 'coziness of a room' should be defined precisely in specific terms.<sup>2</sup>*

Richard Neutra, like Gropius, was a strong advocate of the need for objec-

<sup>1</sup> S. Giedion, *Space, Time and Architecture* (Cambridge, Mass., 1974).

<sup>2</sup> W. Gropius, *Scope of Total Architecture* (New York, 1970).



tive behavioral information as a basis for design. Furthermore, he saw the need for research, and had a more realistic view of the effort required than did many other architects who have expressed opinions on this matter. He wrote:

*An essential task confronting the designer is that he familiarize himself with regularly recurrent responses, which can be considered basic or universally dependable. The next problem is that of furthering or eliminating, as the case may be, conditioned reflexes that have become associated with basic responses through habit or tradition. The designer will need to gather objective information about which responses are wholesome in a given situation, and he will also have to be ready to account for his own goals in the same spirit. In order to understand the motivations he wishes to manipulate, he must be patient to compare their functioning in carefully arranged situations of gratification as well as of frustration. He must call to his aid the experimental psychologist and permit him where possible to introduce safe quantitative methods of verification, where formerly connoisseurs referred to intangible qualities and imponderables.*

*If the reliable findings of which we speak at first come trickling in slowly and in small numbers—compared with the formidable flood of full-page advertisements often so irresponsible as far as true-life needs are concerned—they will nevertheless become in time a much more trustworthy guide in helping us toward sounder decisions of design and acceptance.<sup>3</sup>*

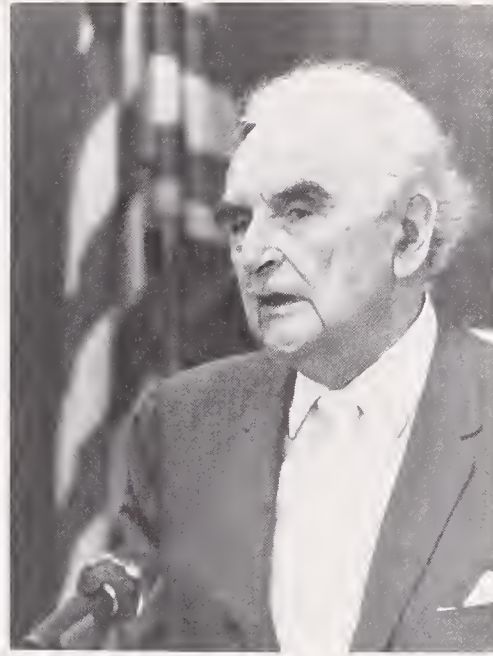

Richard Neutra (HUD)

With the limited exception of research at several European laboratories, there has been little systematic effort to produce and use better information. Instead, M/E research has been largely piecemeal, the result of efforts by a small number of professionals, universities, design organizations, and clients who have become convinced of its importance.

The architect who works on M/E research problems will have the opportunity to become familiar with the scientific procedures employed to collect information. This will also enable the architect to more effectively interpret user information. At present, data are often misapplied due to unfamiliarity with research procedures and limitations.

<sup>3</sup> R. Neutra, *Survival through Design* (New York, 1969).

## Building Design

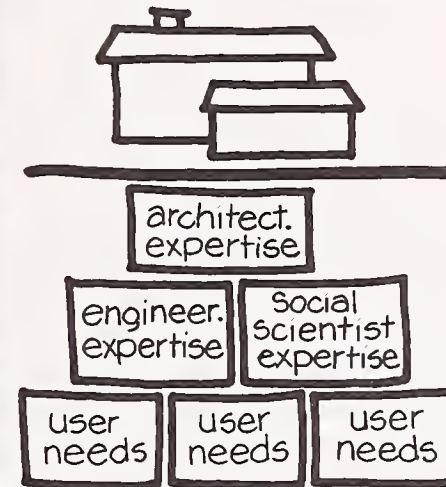

Social scientists, on the other hand, will have the opportunity to work on the long-neglected problems of how people respond to the complex environment of buildings. They can also contribute in an important way to an improved work and living environment produced by better buildings.

Several key issues stand in the way of effective cooperation between architects and social scientists. They include different, often conflicting professional goals, value systems, styles and, perhaps most important, methods of solving problems.

One major hurdle is the rather haphazard and intuitive approach used to define the requirements of building users. It is ironic that although buildings are usually designed to serve people, the hardware components of a building—

such as its shell, heating, ventilation and air conditioning (HVAC) and service system—are carefully planned, whereas occupant requirements, the main reason for building, are often downgraded.

The two professions need to agree upon a vocabulary, designed to exchange information with a minimum of confusion. Architects should be more familiar with information conveyed in research reports. Social scientists should learn to read drawings.

## Common Vocabulary Needed



Social Scientist

architect



## Strengthening Existing Links

In the past decade, an abundance of journal articles and books has stressed the need for better behavioral information in the building design process. Organizations and periodicals have sought to bring social scientists and architects together, and many conferences have been held for the same purpose. All this has helped, but problems surfaced at the same time.

Participants at conferences and contributors to publications have become quite inbred. An infusion of new blood and new ideas is essential if M/E studies are to have any serious effect on building design. Both the design and research ends of the spectrum must be broadened. For example, architects and builders on major projects should be induced to participate in the dialog as should researchers now working at the boundaries of M/E issues—e.g., psychophysical visual research.

A major incentive for cooperation between the two professions is the increasing use of the performance approach in design.

*The performance approach demands a statement of performance in terms of function. Since buildings serve people, function as defined by the attributes is necessary to satisfy human requirements. The means of delivering an attribute is left open, ... the philosophy of the performance approach begins and ends with—and puts its principal emphasis on—the satisfaction of human needs.<sup>4</sup>*

The emphasis on the building user in the performance approach is a useful framework for cooperative efforts—both at the planning phase of work and during post occupancy evaluation. The concept of activities forms a vital link between the professions. The primary function of a building is to enable particular activities to be performed within it. Discussions between architects and clients are focused primarily on adequately identifying the activities of building occupants.

Social scientists are also concerned with activities, whether or not they take place in buildings. They often observe behavior such as walking, talking, manipulating objects, responding to visual and auditory signals. These kinds of behaviors can for the most part be described in terms of being analytic elements of activities—tasks. For example, the activity of driving a car in traffic consists of many tasks—*seeing* traffic signals and other automobiles; *hearing* traffic sounds; *steering* the car in traffic, etc.

The professional schools are a good place to start cooperative interdisciplinary efforts. Architectural schools increasingly employ social scientists as faculty (or in an informal role) in their training program. An even closer academic working relationship between the professions and the formulation of interdisciplinary curricula could go a long way toward establishing a lasting bond between architects and social scientists.

## Developing New Links

One of the greatest gaps is an almost total lack of critical evaluation of buildings from the standpoint of how well their occupants are able to perform their intended activities. Without information of this kind, no meaningful feedback to the design process is possible and buildings will continue to be designed without learning from the past. Intuition, opinion, and judgment rather than facts, will continue to dictate design solutions.

Therefore, evaluative procedures must first be developed, and then standardized. Since M/E studies cover such a broad range of activities, a catalog of research methods should be developed and used selectively as appropriate for a given design problem. When these approaches are agreed upon and standardized, then a body of accepted information can be collected and made available as the next generation of buildings is designed and built.

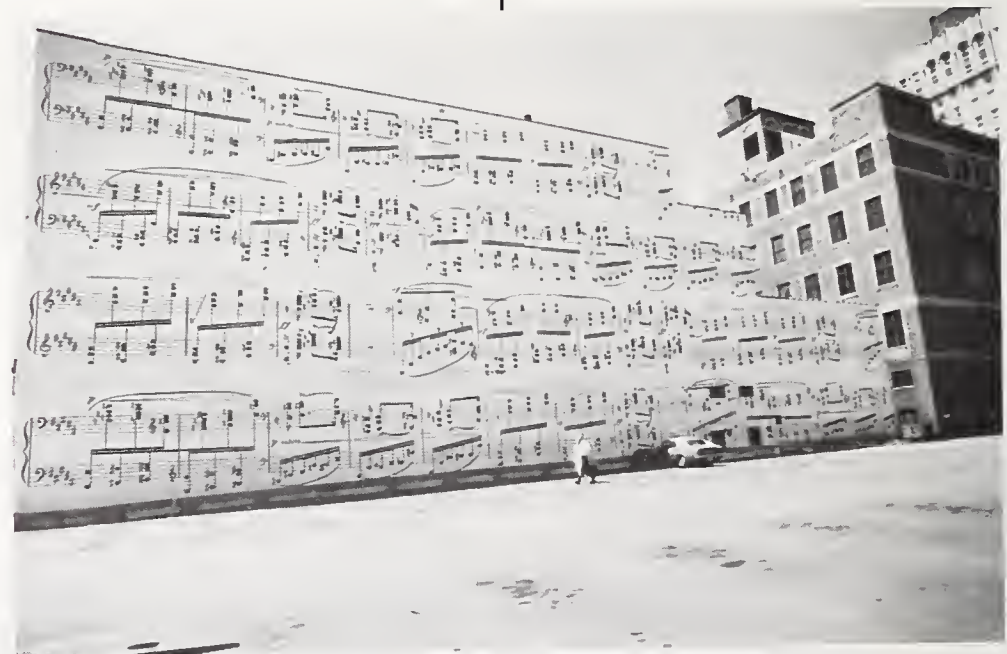

*Building Modification by Users (EPA Documerica)*

<sup>4</sup> J. R. Wright, "Performance Criteria in Buildings," *Scientific American*, 224 (1971).



## Goal of This Work— Better Understanding Between Professions

This work is designed to enable the architect to better collaborate with researchers on joint efforts.

A further objective is to acquaint the designer with the research methods and information available from the many disciplines which touch upon M/E relationships. Since the study of building users is thought to be in a formative stage of development, we should better define the boundaries of the field of study. Problems should be explored from contexts as diverse as geographical features of the environment, man-made objects, social factors, perceptual, and physiological responses of people.

The methodologies included in this work cover behavioral measurements for the most part. Our purpose is to illustrate the broad range of techniques available to develop better M/E information. The reader should be cautious about accepting the findings or applying the particular studies included in this volume. Our concern is to stress the inherent flexibility of these methods in terms of potential application to design problems. Such flexibility is essential if methods are to be standardized, yet not act as constraints on architects or researchers pursuing their investigations.

## User as Design Participant



Building users will have an increasing influence on building design. We must devise procedures which will enable users to influence building design decisions. We must also develop design/use information showing how the attributes of a building and the behavior of people interact. Finally, building regulations and criteria for the most part deal with the health, safety, and performance of building users. (Yet, as we note throughout this work, much of the behavioral information which serves as the basis for regulations, criteria, guidelines, and standard architectural practice is questionable—e.g., lighting, acoustical criteria.)

The social scientist is trained to collect information using standardized procedures (scientific method), and to observe *people* rather than *things* or *phenomena*—as is the case with physical scientists. Consequently, the social scientist can provide immediate help in developing better user information. The social scientist can also draw upon and interpret the research literature already available.

## Compatibility Of Science And Design

Is the design process incompatible with the methods employed in science?

We think not.

Giedion expressed his views about the relationships between factual data and design in the following manner:

*What our period needs is to gain an understanding and a general view of the dominant methods in different activity, recognizing their differences and likenesses. A general contemporary understanding of scientific method is more important for our culture as a whole than widespread knowledge of scientific facts. It is through their increasing similarity of method that the various activities of our times are drawing together to constitute one culture.*

*There is this remarkable circumstance which we can observe today: sciences which differ widely in their objects are beginning to resemble each other in their methods. A continued and extensive search for exact knowledge is at the bottom of this growing resemblance. It is being recognized in all quarters that the ideas which we have taken over from the past are both too complex and too crude. But science is not an activity which goes on independently of all others. Each period lives in a realm of feeling as well as a realm of thought, and changes in each realm affect the changes in the other. The solution to the problem of the separation of thought and feeling lies in the incorporation into science of the realm of emotion as it is expressed in art.<sup>5</sup>*

<sup>5</sup> Giedion

## Improving Building User Information

In our view, two parallel approaches are required to improve building user information. One would be designed to meet short-range requirements; the other would focus on long-term objectives.

To meet the immediate needs of the designer, we must make greater use of the design-related information already available. Experienced researchers will know of sources of data not familiar to architects, and their backgrounds will enable them to interpret the findings appropriately. An alternative is to upgrade the designers' understanding of behavioral research findings so they can make better use of the data generally accessible to architects. In some instances, a design team may have the opportunity to collect data by means of interdisciplinary research.

The long-term research efforts should be geared to advancing user requirement studies from a practitioner's art to a science. The present work stresses measurement methods for the orderly development of information. This should contribute toward a consensus among architects and M/E researchers as to: *What* should be measured; *how* to make measurements, *how* to assimilate this information into the design process.

The standardization of research methods constitutes a major step toward assembling a body of M/E facts—information dealing with M/E problems and available to all architects.

# Research Development of Improved M/E Information

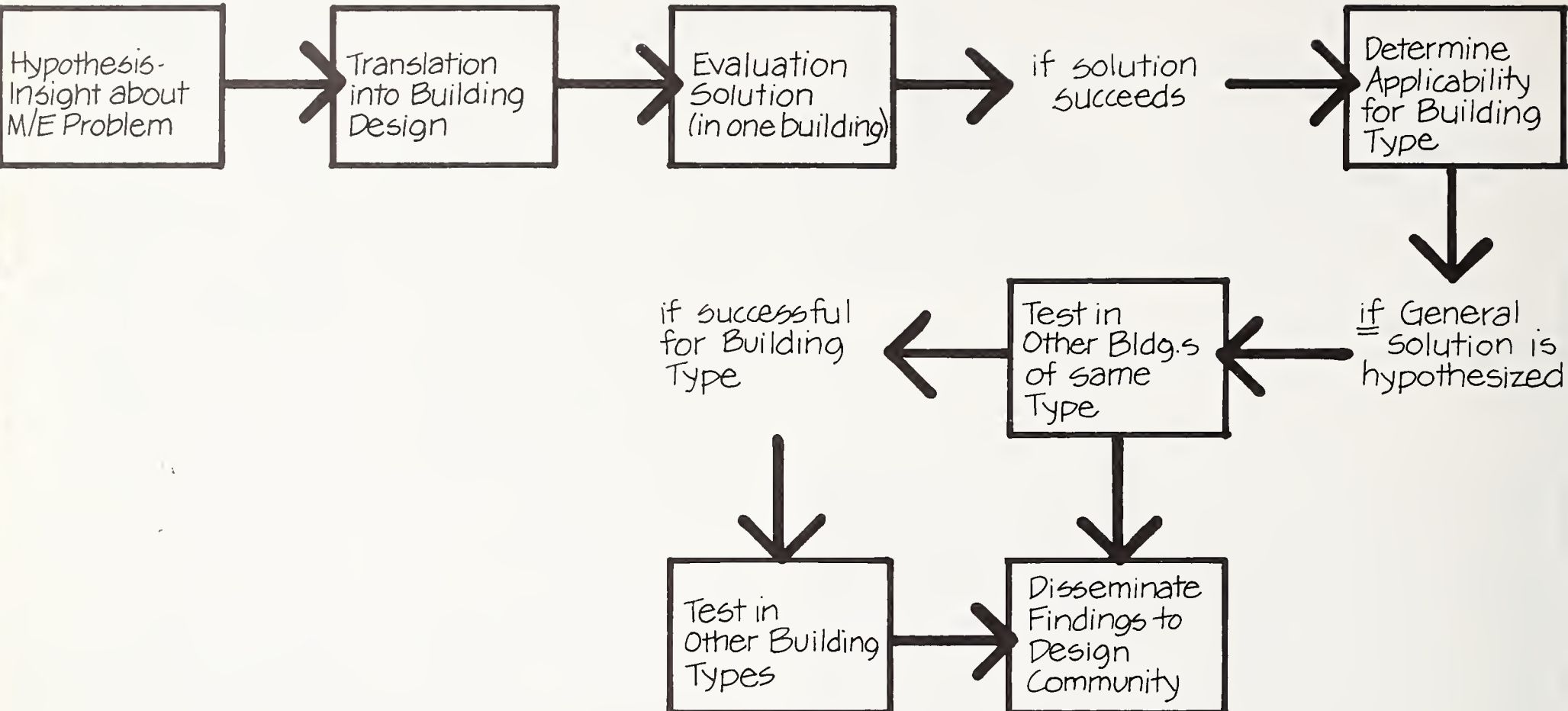

The researcher brings to this task a systematic approach to problem solving and a desire to be objective in his work. On the other hand, ingenuity and innovation do not necessarily go hand in hand with scientific research—since a person well trained in a subject is sometimes less likely to think about problems in novel ways.

Thus, the viewpoint of the architect is vital and may be just what behavioral researchers working as design team members need to identify and tackle problems which they have either not yet recognized or have until now ignored.



# 2

## Background

New Factors Affecting Design

User Requirements—What Do We Know Now?

Building Users

Differences Among Occupants

Requirements

Design by Team

Architects and Social Scientists

M/E Cooperative Efforts

Experimental Research and Design

Human Engineering as a Team Enterprise

Conclusion

The highly publicized experience of the St. Louis, Missouri Housing Authority with the Pruitt Igoe Project provides a dramatic illustration of a failure in the design process. (A multi-million dollar complex of relatively new apartment buildings had to be destroyed because it was unsuitable for the occupants.) A major reason

for this outcome was that the designers apparently failed to understand the life style of the people who were to occupy the housing. Although the stated goals for the project appeared reasonable—upgrading the living conditions of slum dwellers—the design solution was totally inappropriate.



*Pruitt Igoe—Before (HUD)*



*Pruitt Igoe—After (HUD)*



The notion that building design in itself could have a major impact on life style was naive. Poverty, unemployment, and crime were everyday problems for the inhabitants of Pruitt Igoe, but these underlying social problems were not appropriately addressed. For example, the prospective housing occupants were not consulted by the designers. Had they been part of the planning process, they may well have pointed out that the proposed plan was made to order for the criminal. Walkways inside and outside the building, alcoves and elevators, made an ideal environment for illegal activities (robbery, assault), which would ultimately result in the failure of the project.

Unfortunately, while Pruitt Igoe is not a typical problem; neither is it an aberration.

What circumstances permit buildings to be design award winners and at the same time fail from the standpoint of their occupants?

Reasons may be found within the design profession and the society in which the architect functions.

R. Sommer (psychologist) writes that *awards and fine arts type of criticism have encouraged monumental buildings that are often hard and oppressive. They have also neglected the responses of occupants and non-designers.*<sup>1</sup> He cites as an example the award winning art/architecture building at Yale University:

*It is, perhaps for these reasons, not an easy building to live with. Physically it is often uncomfortable. It gets hot when the sun pours in. Security controls are difficult. Offices are cramped. The spaces are not perfect for twenty-foot high paintings or intimate conversation or classroom study. The lighting is inadequate. There are great difficulties in manipulating one's personal environment.*<sup>2</sup>

A major problem faced by the architect sensitive to the needs of obtaining user requirement information is the lack of time and resources to develop the necessary data. Most clients simply have not been convinced that an expenditure of money for this purpose is a worthwhile investment. Lack of funds makes it either difficult or impossible to hire consultants to deal with the problem. The architect must then fall back chiefly upon his own resources. As a result, some architects will be successful and others less so—based upon individual abilities and experience.

While the development of user information for design has been a problem in the past, it is likely to pose an even greater burden in the future.

## New Factors Affecting Design

The ability of the design profession to operate in the future as it has in the past is being questioned. Recent developments have worked against a "business as usual" attitude toward design. Some factors directly impinge on design; others work indirectly.

The economic viewpoint, which has dominated the building design and construction process, is focused on one type of expenditure—first cost. Due to economic and other pressure, many builders and owners are taking a fresh look at this traditional approach, recognizing long-term costs

of building operations. The cost of energy has greatly accelerated this development. One study has shown that approximately 90% of the total dollars spent during the expected lifetime of a commercial building is accounted for by salaries paid to employees. Building construction costs are thus seen from a standpoint seldom considered by building client/owners.

The United States has been richly endowed with natural resources but has often been wasteful. Material shortages have been few. Now the concern for environmental quality, combined with the energy crisis, has altered the views of many people. The waste of depletable resources is becoming unacceptable to the average citizen.



Reusable Resources (EPA Documerica)

<sup>1</sup> R. Sommer, *Tight Spaces: Hard Architecture and How to Humanize It* (Englewood Cliffs, N.J., 1974).

<sup>2</sup> Sommer



There is a growing sensitivity to the need to conserve and recycle materials. Current concerns about energy reflect a major change in the priorities of our government. The building industry, as well as other segments of society, will be seriously affected by energy conservation, which will lead to a greater concern for energy use in new building designs. One illustration of the response to materials shortages, pollution and energy waste is the development of new technologies: (1) to recover waste heat (e.g., from lights) for building and community use, (2) to produce additional heat by the combustion of waste materials produced by the occupants of buildings and communities, and (3) to allow the use of solar heating.

Not long ago, only a few individuals and institutions were outspoken in

their concern for environmental quality. This is no longer true. The exploration of the moon and the televised view of the earth from outer space have had an enormous impact around the world. The space program made the "planet earth" a meaningful concept for the layman. This experience heightened the awareness of many people that waste by-products from manufacturing and other activities badly degrade our environment.

The efforts to maintain and improve our environment have taken a variety of forms all of which have important design implications. For example, within the past few years highways planned in New Orleans, New York City, San Francisco, and Washington, D.C. were not completed because local citizens opposed their construction.



*Uncompleted Highway (NBS)*



*Planet Earth (NASA)*



The burgeoning consumer movement is another indication that people are becoming increasingly dissatisfied with many of the products that they purchase. Programs at several levels of government have been developed in response to the call for better products. Private organizations and local citizens' groups seek more and more to respond to consumer needs. Aspects of both the consumer and environmental quality issues affect the built environment. Questions have been raised about the adequacy of buildings, neighborhoods, cities, and recreational areas. Shouldn't the architect be expected to work to create an environment which is pleasant and even enhances people's activities?

Possibly the strongest force in today's society is the profound skepticism of many people toward values, traditions, beliefs, and institutions which not long ago were taken for granted. Fewer people are willing to accept the judgment of experts in matters that vitally concern the individual. For example, the construction of power plants using atomic fuels has met widespread opposition from individuals and groups in the vicinity of the planned sites, despite repeated assurances by experts as to their safety. The point is further illustrated by the skepticism exhibited by the general public concerning the judgment of those who describe the nature and extent of the energy crisis.



*Consumer Activists (AIA Journal)*

Architects, planners, behavioral researchers, politicians, and economists are among the professions which have been sharply criticized by the people whom those groups supposedly serve. Instead of relying on the judgments of experts, which often conflict, private citizens have organized to deal with issues of local interest.

While the feelings and attitudes of people represent subjective influences on design, the information explosion in the design disciplines points to a problem of an overabundance of data. Improvements in materials, technology and processes combined with scientific advances in the physical and social sciences have led to information overload. For the architect who requires information on a broad range of topics, the problem is far greater.

How feasible is it for the architect to become appropriately informed?

The answer is that no one individual or small group can master all of these data. Consequently, building design must follow another course.

### Design Factors

---

- Long Term Use of Buildings
  - Resource Limitations (Financial, Natural)
  - Conflicting Priorities
  - The "Information Explosion"
  - Questioning of Traditional Values
  - Concern for "Quality of Life"
-



## User Requirements—What Do We Know Now?

A review of the work dealing with user requirements presents a very confusing impression. Whether reading reports or books, attending conferences, or participating in discussions on the topic, no coherent picture emerges. Above all, there appear to be few clearly defined goals or ways to attain them. Rather, countless individuals are working to solve particular design problems. In short, we face an almost classic case of a field of study in its infancy, struggling to get organized.

Where does one look for information on the subject? What are the primary sources? In what form does the information appear?

The data may be found in countless places—often where they are least likely to be sought. Engineering handbooks, psychological textbooks, design manuals, building codes, and survey findings are all potentially major sources. In many instances the information is inaccessible to those who need it. The difficulties are due to many factors, e.g., type or form of publication.

Many user requirements are not easy to identify. This is especially true for codes and regulations which, in effect, specify design characteristics of buildings. These regulations are often based on implicit user requirements, rather than on clear statements of need. Take, for example, stairway width requirements—presumed adequate for emergency evacuation of building occupants.

## Single Sourcebook of Information

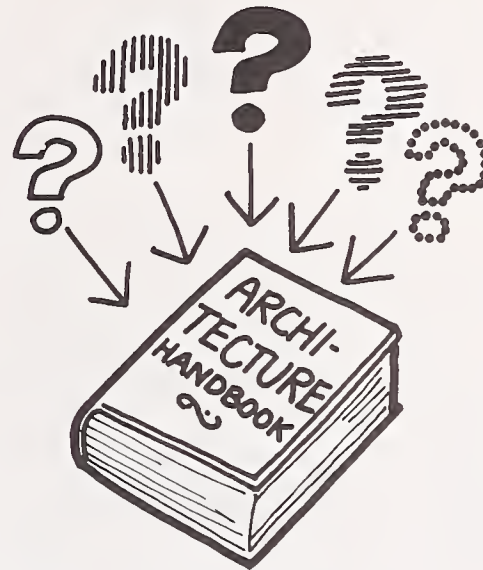

Minimum property standards and building codes are major repositories of such information, since they deal mainly with the safety requirements of buildings. These regulations typically evolve over a long period, and are modified whenever building design practices are thought to contribute to illness, injury, or loss of life. For example, fire regulations designed to ensure a degree of safety for one range of materials are not appropriate when materials have a different set of properties. The widespread use of plastics, which have posed new smoke hazard problems, is a recent instance where current fire regulations often do not respond to the current safety needs of occupants. The architect can therefore meet code regulations (developed to meet safety requirements) and still fail to respond to the everyday needs of building users.

The avoidance of these problems makes up a legitimate and reasonable set of user requirements. Relating regulatory requirements to the way they respond to the safety and health of occupants is often difficult, however. Codes often stem from discussions of technical groups, standards organizations, regulatory officials, and proponents of different viewpoints in the community. Written records of such activities are rare; and the reasons for decisions, compromises, etc. are therefore hard to determine. This makes it difficult to evaluate such regulations from the standpoint of the user.

A major difficulty with resorting to regulations to define user needs is the inertia of the regulatory process. Once a problem is dealt with by a code or other means, the regulation may remain on the books indefinitely. In a sense, then, regulations are a response to the cumulative history of *past* design failures. Major changes in building practices, health standards, social customs, and technology, which could make many regulations obsolete or even counter-productive, are reflected in regulations very slowly.

Regulations have influenced building design in another important way. One reason for the criticism of guidelines, codes, and regulations designed to serve one function is that they have been used for another. For example, even though *minimum* property standards and building codes were developed to ensure minimum safety they have been used to define user requirements. Designers who follow these standards settle for meeting mandatory regulations rather than striving for higher quality.

## Regulations as Past History of Design Failures

Codes/Regulations

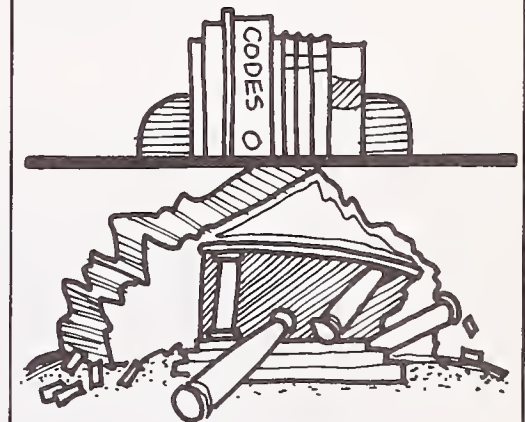

Design Failures

## Building Users

A logical starting point for an analytic treatment of user requirements is to define common terms. Consider the word "user." When reviewing written and verbal material by researchers and practicing architects, one finds no generally accepted definition of the "user." Worse, the term is seldom defined.

Users are typically thought of as occupants, e.g., those who visit, reside, or work in buildings. Less attention is given to those who may be termed "indirect users" of buildings—those who make observations because they are nearby or have an unobstructed view. For example, passersby, tourists, and occupants of nearby buildings are all exposed to the facades of buildings which they may never enter. They, too, are building users.

The design literature indicating how architects develop a design program, employs a broader and much fuzzier concept of the user. The term is applied to many of those involved in the construction, ownership, operation, and maintenance of a building as well as to the building occupants. The blurring of the concept "user" is an important cause of many problems encountered by those trying to design buildings which are responsive to users. Let us now consider some building users.

**BUILDING USERS:** Both direct and indirect users should be considered.

### Direct Users

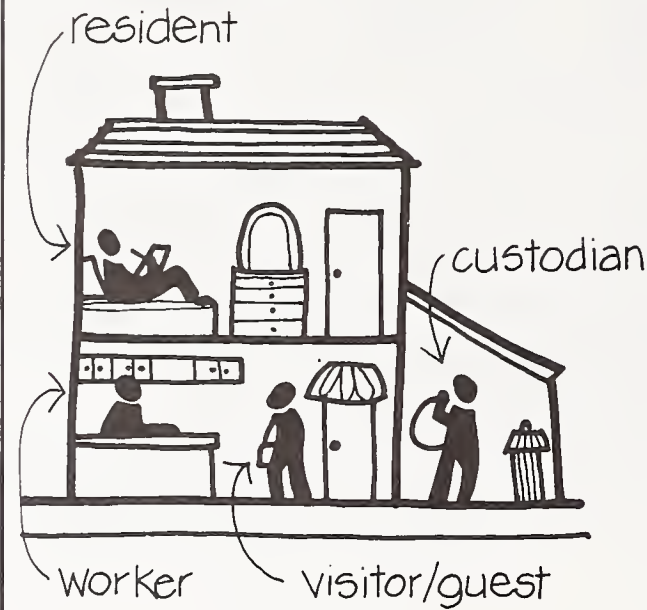

### Indirect Users

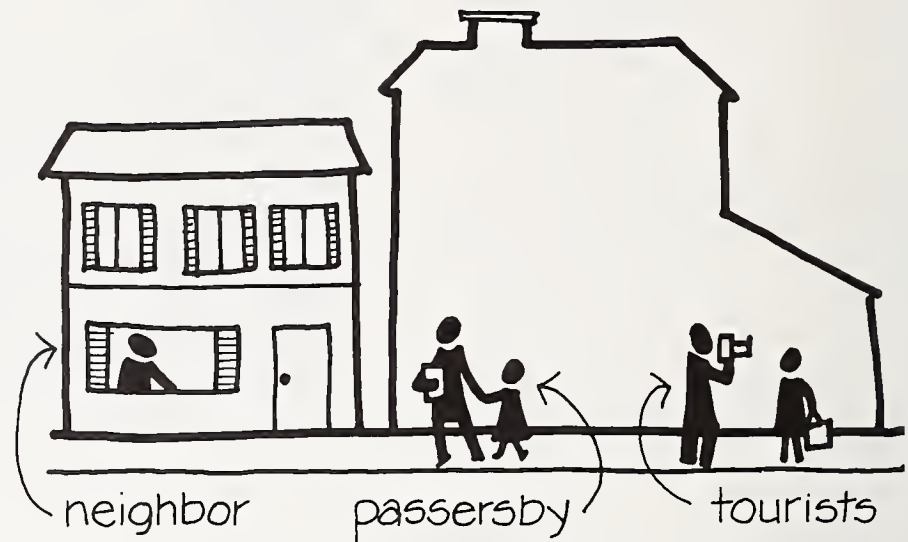

The *builder* (or the organization financing construction) is an extremely important building user. For example, in a speculative building, the concern of the builder is to build a safe structure (meeting local regulations) which can be sold at a profit commensurate with the investment and risks taken. Under these circumstances, the builder is likely to define user requirements in a manner similar to the architect—on the basis of experience and judgment. Concern for building acceptability is likely to be limited to those factors which influence the sales potential and market value of the building. Builders of speculative structures therefore have a limited stake in satisfying occupants' needs.

The speculative builder is only one illustration of the builder as user. Many large private and governmental organizations build and later occupy buildings. The success of such buildings is largely determined by their responsiveness to the requirements of those who occupy them. These buildings do not have to compete in the marketplace—they are built to carry out the activities of the organization that built them. Furthermore, it is likely they will house these activities for a long time. Even if the buildings are unsuccessful, they will continue to be used (due to factors such as organizational policy, size of initial investment, and location).

Organizations which build and own their buildings, including institutions such as schools and hospitals, have much to gain from an upgrading of user requirement information. Unlike the speculative builder, they have a vested interest in the long-term success of a building, i.e., the performance of day-by-day building activities over the lifetime of the building. Organizations with continuous building programs (educational institutions, government) have a special responsibility to evaluate current buildings and to use the findings to improve the performance of future buildings. They should undertake research because, being service organizations, their task is to respond to their clients—the public.



Consider now the *building owner* who rents space to others. The building owner, unlike the builder, is vitally concerned that a building works adequately for its occupants. The returns on investment depend largely on the degree of success achieved in renting space profitably. Dissatisfaction by building occupants is therefore directly translatable into unleased space, the owner's investment. Moreover, since the owner is concerned with long-term investment (where leases are periodically renewable) the long-range satisfaction of building occupants cannot be ignored. On the other hand, little incentive exists to provide services which add to expenses without yielding corresponding benefits.

The *building manager or operator*, responsible for the smooth day-to-day functioning of a building, is a key link between the owners and occupiers of buildings. Since the term "building management" covers a broad range of responsibilities, we will only mention a number of general problem areas to note when operators are considered building users. These problems may be classified thus:

- *The building and its subsystems*—including preventive and other maintenance, repairs, replacement of materials, components, equipment.

- *The interaction of people (building occupants, maintenance, and management personnel) with the building and its subsystems*—efficiency of operations, control of energy use, functioning of safety systems, setting and modification of environmental controls (lights, heat).
- *Communications among management, ownership and occupants*—responding to needs of occupants for information, services.

The *maintenance force* is the working arm of the building operator. Unlike other users, the maintenance force directly experiences most features of the building, bad and good, every working day. This experience is tangible, immediate, and of long duration. In this respect, the maintenance force has much in common with the building occupants—it is a special kind of occupant.

Finally, there is the *building occupant*. The building forms a backdrop for activities during approximately half of the waking hours. When we use the term "user" we refer to the occupants of buildings. The term "occupant" is not a simple one, and could easily lead us astray. Occupants should be seen in terms of the major activities performed in the building. For example, in a hospital the occupants are patients, nurses, doctors, technicians, maintenance people, and visitors. Each of these occupant groups perform important functions within the building, and these must be considered by the architect.

When we review the user groups, we note a paradox. The group with the least interest and concern for the day-to-day operation of the building (the builders) has the most ready access to the architect and therefore the greatest influence over user requirements. The occupants (and maintenance force), who are most immediately affected by design, have at best limited access to the architect—unless the architect makes a point of consulting them.

### Differences Among Occupants

The designer is more likely to consider differences among people when a readily visible distinction (e.g., age) is apparent (and important). On the other hand, many subtle psychological, cultural, and social factors

exist which may be extremely important for the designer to consider but which cannot be readily identified.

Unlike the subjects of research in the hard sciences, people have memories of past events, the ability to learn, a cultural and biological heritage, and many other attributes which serve to distinguish individuals from one another.

In many situations the designer may not be able or even find it desirable to take most of these (or other factors) into account. He may decide that the typical building user is the "average" person. When the architect follows this procedure, many sources of data are available. Any study of behavior, however, which assumes that people are essentially similar in their behavior risks ignoring the particular needs of people. (See chap. 7.)

### All People Are Not Alike

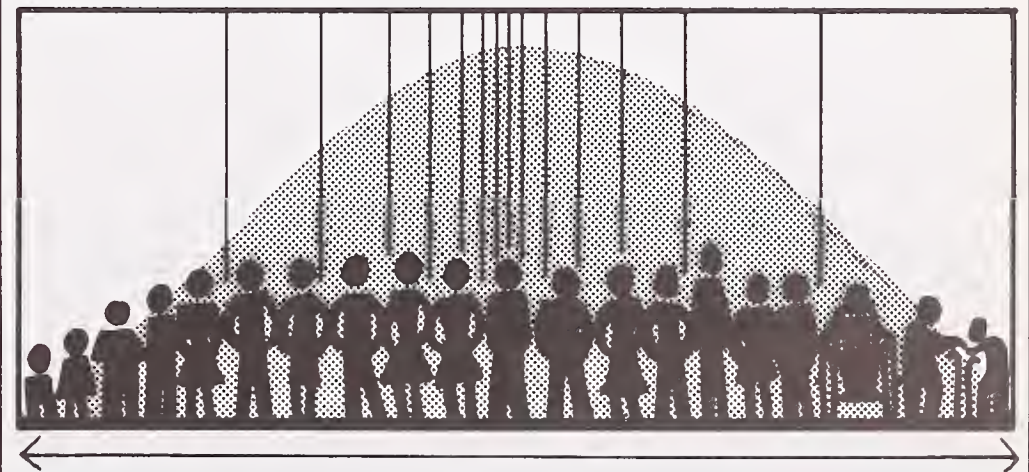



From a M/E viewpoint, these special kinds of users are important because environmental characteristics recommended for one group may be totally unsatisfactory for others. For example, consider *age*. In the design of housing for elderly people, bear in mind likely difficulties in walking, seeing, and hearing. These factors should be considered when planning illumination levels, passageways, emergency signals, and exits. At the other extreme are design requirements for children, such as the need to ensure that classroom furniture responds to the needs of children, not of adults. (Naturally, the requirements for the aged and children must likewise be considered in buildings not specially designed for these groups.)

**Personal and Cultural Attributes**  
(Differences Among People)

- Age
- Sex
- Health
- Education
- Economic Status
- Social Status
- Nature of Employment
- Ethnic Heritage
- Racial Heritage
- Religious Heritage
- Previous Experience
- Expectations
- Motivations
- Attitudes

**Requirements**

Just as there have been many definitions for "user," many viewpoints have been expressed concerning the nature of "requirements." Some definitions have been rather restrictive, confined to the minimum physiological requirements consistent with health and safety. Others have encompassed areas of interest now identified with improved quality of life. Most architects and researchers have occupied the middle ground.

A number of designers and researchers have developed conceptual models for defining requirements in recent years. One of the most comprehensive and widely used schemes was developed by A. Maslow (psychologist), who treated human needs as an ever-changing process, rather than as a fixed set of requirements that apply to all people. This model was selected for discussion for illustration only—alternative approaches have been advocated by others, and we have no quarrel with any of them. Maslow's conceptual model is termed the "need hierarchy system." It assumes that complete satisfaction of needs is not possible because when one set of needs is satisfied, another set emerges.



*A Subculture in the United States (Authors)*

**Hierarchy of Needs**  
(Maslow)

- self-actualization
- self-esteem
- belonging
- safety
- physiological needs

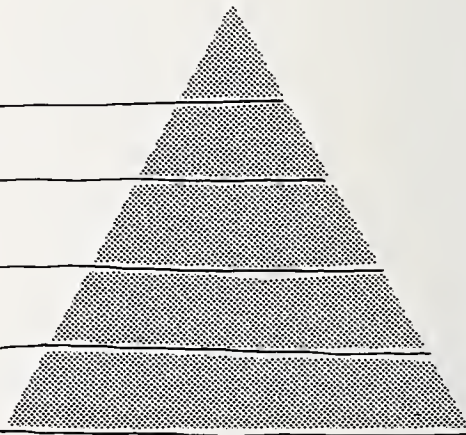



The need hierarchy starts with the basic physiological requirements to sustain life and health. Without being able to satisfy these needs, the individual cannot survive for any length of time. When these basic requirements are met, usually associated with food, clothing, and shelter, safety needs emerge. The individual becomes concerned about security, the avoidance of harm and the need for protection. These needs are still oriented toward survival in a hostile environment. After some measure of safety has been assured, a need to belong becomes apparent. The individual strives to be a member of a group. As a group member, one strives for maximum acceptance by peers. This need is demonstrated by a reluctance to be a standout—either by excelling or failing in group activities. (Group membership may be extensive—e.g., social, work, family, professional.)

When a person has achieved the goal of being accepted by a group, ego-status needs come into play. The individual tries to excel and thereby achieve status within an organization, and/or among professional peers. Ego-status needs are satisfied in tangible ways, e.g., larger office, carpeting, expensive desk, and intangible ways, such as being treated with deference and respect. Finally, Maslow says recognition by others is inherently limited and one strives to fulfill one's own highest needs by what he calls *self-actualization*—the need of a person to strive for the fullest potential as a human being.



*Basic Survival Needs (NIH)*

Maslow pointed out the conceptual and theoretical nature of his system, which should be applied figuratively, not literally. People do not move from one level to another in any precise fashion and many of the needs are seldom completely satisfied. For example, a professional who wants to satisfy a need for ego-status may, if he loses his job, find he is trying to satisfy basic needs. Many people ignore the intermediate levels of Maslow's system and work toward self-actualization—artists and writers exemplify this process.

Maslow's system shows that most of the industrialized nations have advanced to the higher level needs above the physiological and safety requirements.

The research literature dealing with the subject of user requirements in buildings has a very narrow base. It is almost uniformly produced by and for professionals who work and live in highly industrialized societies, with relatively high standards of living. Coming from this cultural background, requirements reflect the affluence of these cultures.

Consequently, the research community thinks primarily in terms of requirements of belonging, ego-status and self-actualization.



However, there is an "underdeveloped" world which should not be neglected. The late Constantinos A. Doxiadis (Greek architect and city planner) discusses this problem:

*... If we proceed to look not at the facades of our buildings but inside, into the heart of our architecture, we shall discover that the homeless or poorly housed millions who constitute the majority of the people on the earth, live under very bad conditions indeed. ... we must recognize that we have quantitative as well as qualitative problems to tackle, and that the qualitative problems should not be left to one side while we devote our attention mainly to the quantitative ones. If this bias continues, then we are doomed to remain in the epoch of transition. We will be unable to find any way out and, what is worse, our efforts to serve our real clients, that is, the population of the*

*whole earth, will be a complete failure. How can we believe that we create an architecture when the solutions given are only good or possible for a certain very small class of people which may exist in all countries or only in some of them, but which nevertheless constitutes a minority in relation to the great masses of people we have to serve?*<sup>3</sup>

This problem is not limited to the underdeveloped world. Rather, many technologically advanced societies have in their midst groups of people badly in need of improved basic shelters.

Our discussion thus far has addressed the question of who the architect should try to satisfy when making design decisions. If we assume that the occupant is the user of concern, then how should buildings be designed to better meet his needs?

## Solutions to M/E Problems Are Often Suitable for only a Percentage of the World's Population

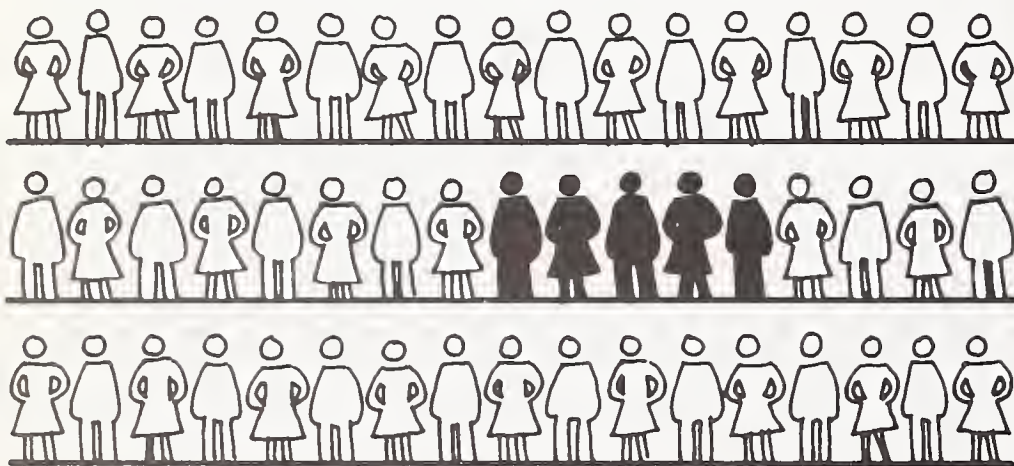

<sup>3</sup> C. A. Doxiadis, *Architecture in Transition* (New York, 1968).



Underdeveloped World (NIH)



## Design by Team

The trend toward team design continues. The architect is usually a team leader (or member) coordinating the activities of many experts working toward a group solution of a design problem. The other members of the team are selected on the basis of needed expertise. For a school, a basic team might be augmented by experts on teaching, child behavior, and perhaps lighting and acoustics. The team concept has not subordinated the role of the architect, it has merely changed it. The more complex the design, the greater the need for the architect's ability to integrate and synthesize information.

W. Caudill (architect) was a pioneer in the development of the team approach to design. He notes that:

*When we consider the problems facing this country and other nations which must rebuild old cities and build new ones just to keep pace with current demands; when we consider the war on poverty and the necessity of providing architecture for all people; the need is obvious for large interdisciplinary teams which attack problems from all directions at once. Giant projects require giant teams, not prima donnas.*

*There must be a major onslaught by teams of many disciplines.*

*Isolated effort by an independent architect working alone will not do the job.*

*The so-called "great man" approach must give way to the great team approach.*

*From now on the great architects will be on great interdisciplinary teams.<sup>4</sup>*

S. Kliment (architect) feels that the architect has too often made major decisions based on hunches. *This worked in the days of few and well-trying options—in structural systems, heating and ventilating, enclosure, plumbing, as well as project management concepts; so the architect was able to pour his energies into the creation of forms in the role of artist-designer.*

*Today, the options are too many, the turnover in techniques is too swift, and the nature of these techniques too sophisticated and exacting for architecture by hunch to be any longer valid. The new client expects from his architect the latest in technical and management expertise.<sup>5</sup>*

"Architect" cannot be spread all over the dictionary or the architect will end up trying to be everything, doing nothing well. The most important role that the architect must play, and this should never be forgotten, is his role as the professional liaison between arts/humanities and science/engineering. In one sense, he is the most general of the generalists. What other profession demands that its members be part artist and part scientist?

What can behavioral research contribute toward improved designs by team in the future? The strengths of social scientists are in making observations and measurements of human behavior using the scientific approach—two major problem areas identified earlier.

## Informational Requirements for Design

- specific facility requirements
- site development requirements
- characteristics of the occupants
- characteristics of the site
- objective of the master plan
- relative location and interrelationship of spaces
- functional requirements for the facility
- flexibility needs for future growth and changes
- priority of needs among requirements
- special restrictions and limitations
- budget

## Architects and Social Scientists

If we approach design as problem solving, we see a number of characteristics of each profession which can lead to conflicts. They deal with the performance of day-to-day activities and thereby describe basic work styles and habits, which are not readily modified.

The goal of the architect is to complete a building which is functional, yet permits the expression of creativity and individuality. The basic procedure employed in design is the manipulation of spaces, forms, materials, and objects—all having three-dimensional (tangible) characteristics. Architecture is frequently described as the "knack of manipulating spaces" and designers therefore care deeply about concepts dealing with space usage—territoriality, crowding, privacy, distance perception, spatial mapping. The use of space appears to be a source of conflict between architects and building occupants: architects often claim that building occupants do not use spaces for the purposes for which they were designed. On the other hand, occupants complain that spaces are unsuited to the required activities.

Architects are at times accused of considering themselves the standard for acceptance of their own designs. In this way they introduce their own socio-cultural views of comfort, community and other aspects of design to social and ethnic groups which do not share their world view.

<sup>4</sup> W. W. Caudill, *Architecture by Team* (New York, 1971).

<sup>5</sup> Caudill

# Interrelations in Building Design

Environment System		Building System		Human System	
Cultural Context	Physical Context	Building Technology	Internal Ambience	User Requirements	Client Objectives
	The site as given in terms of:	Modifications of external environment to provide suitable ambience for specified activities by means of:	Provision of physical conditions for performance of activities in terms of:	Provide for specified activities in terms of the following needs:	Return for investment in terms of:
Social Political Economic Scientific Technological Historical Aesthetic Religious	Physical characteristics: climatic geological topographical  Other constraints: land use existing built forms traffic patterns legal	Available resources in terms of: cash materials labor/equip.  Structural systems mass planar frame  Space separating system: mass planar frame  Services system: environmental information transportation  Fittings system: furnishing equipment	Structural mass visible surfaces space enclosed    Sensory environment lighting sound control heating/vent	Organic: hunger & thirst respiration elimination activity rest Spatial: functional (inc. fittings) territorial  Locational: static dynamic  Sensory: sight hearing heat & cold smell kinaesthetic equilibrium  Social: privacy contact	Prestige Utility Provision for change Housing of particular activities so as to encourage user motivation Security

(C. H. Broadbent, adapted from T. L. Markus: Building-Environment-Activity-Objectives model)



Another source of difficulty is the approach used to compile user requirement information. Case studies and face-to-face discussions are frequently employed as the means of gathering data. Due to lack of time and money, the best available information will be used, instead of waiting for better information to be developed or found. (The architect for obvious reasons cannot wait for better information.) The architect therefore sees himself as a synthesizer of information developed by others, not the originator of new data.

In contrast to the tangible product of the architect—the finished building—the goal of the social scientist is a better understanding of human processes or relationships. Study findings take the form of documents, frequently dealing with the solution of one problem and the identification of others. Written reports often include tables of statistical information and are not readily understandable by laymen, including architects.

The orderly development and improvement of information—the **scientific method**\*—describe the approach used to solve problems. The need for objectivity (obtaining facts) is stressed; so is a distrust of intuition, except for providing the basis for formal investigations—the hunches being transformed into research *hypotheses*. Training and experience tell the researcher to be skeptical about information without a thorough understanding of the subject matter.

\*Words in bold print are in Glossary.

The researcher as a result is usually unwilling to act upon imperfect or incomplete data. Frequently, the researcher sees the need for more studies before considering a problem solved. The common view is that general conclusions should be drawn cautiously and only when several researchers verify the findings. This gradual buildup of information by researchers having similar interests and using similar procedures forms the basis of scientific research.

### M/E Cooperative Efforts

Now we come to a paradoxical situation. The intuitive architect often approaches the behavioral researcher for objective information—and frequently goes away almost empty-handed, unhappy over the experience and vowing not to repeat it.

Why hasn't the behavioral scientist been more helpful to the architect?

The fact is that there is a misfit between the questions architects want answered, and the data available in the social sciences. One stumbling block is the problem of measuring emotional impact, e.g., how can one objectively measure "calmness" and "excitability?" For example, architects often talk about the effects of color on behavior, i.e., how can color be used to create a mood or a feeling? The architect requires factual (objective) information about the effects of an "environmental attribute" (color) to solve a problem which by its very

nature is highly subjective (i.e., emotions). Furthermore, subjective responses of this kind vary widely from person to person, and change with time for a given individual (e.g., adaptation). Social scientists therefore face a formidable challenge when trying to explain the relationship between color and emotional behavior.

Part of the problem is the division of psychology into many subdisciplines—each one dealing with particular problems and using specialized techniques. Emotional responses have been examined by researchers who have not been greatly influenced by the classical research tradition (analytic studies where single variables are manipulated one at a time—see chap. 4). The major goal of these investigators is to find out why an individual behaves as he does. They employ a variety of procedures for an in-depth understanding of a person. (See chap. 7.) Their goal is not to see how environmental attributes affect behavior. Consequently, although they have developed information about emotions, the data cannot be readily adapted for the architect's use. Information describing building characteristics is scarce, making it impossible to determine the relationship between (*correlate*) behavioral and environmental data.

### Experimental Research and Design

On the other hand, the experimental research tradition in psychology is not only compatible with the requirements of architects but seems suited to provide information the architect requires. Experimental psychology began with a *psychophysical* orientation—determining the relationship between environmental characteristics and the way people respond to them.

The psychophysics research tradition dates back more than 100 years and has resulted in a large body of data concerning how people respond to environmental stimuli (e.g., light, wind). Most of the studies performed to date have only studied individual variables, however (e.g., the relationship of wave length to color perception), and are therefore only indirectly applicable to building design problems. One example is studies of the relationships of the variables of sound (intensity, frequency) which correspond to the way that people experience them (loudness, pitch).

Another reason for the lack of user design information is that most of the data were collected to determine how people respond to extreme environmental conditions to meet the needs of military and space travel missions. The desire was to determine the effects of hostile environments on the ability of people to perform their work assignments. No such high priority has ever been given to the more moderate environments of buildings.



The M/E researcher faces a situation very familiar to the designer; the need to synthesize information on a variety of topics in order to develop a reasonable solution to a problem. But, while the designer and researcher pursue the same goal of trying to synthesize information, it is likely they will do so with different types of payoffs in mind. For the architect, such an activity is a *means* to the *end* of solving a problem related to the building being designed. By contrast, the researcher will often focus on the *process* of synthesizing information (how does one perform the activity), to do it more effectively in the future. Solving the particular design problem is often the means toward the end of developing improved methods of synthesizing information.

### Human Engineering as a Team Enterprise

The discipline of human engineering originated during World War II in circumstances almost the same as those which exist today in the design professions. At that time, engineers were designing sophisticated equipment to be used by pilots, operators of radar, weapons, communications, and other systems. They soon learned that more know-how about human behavior was needed than existed in the engineering profession. As a result, design teams including human engineering experts were formed. The historical development of this discipline, now often termed human factors or ergonomics, offers a model for an approach to problems

now being addressed both by the design and behavioral sciences professions. The common interest between engineers and behavioral researchers in human factors studies applies to many design problems. For example, when designing the physical environment, cooperation with the engineer is essential. A model for interdisciplinary work is available in noise research, where physicists, mechanical engineers, and computer scientists are all required to measure the physical environment. Psychoacousticians then study the effects of noise, and acousticians and designers use this information for design.

The readiness of the behavioral scientists to apply imperfect and incomplete data to solve immediate design problems overcame one of the largest barriers to acceptance by engineers. Human factors engineers knew they had to operate this way since the only apparent alternative was that others, less qualified, would make the decisions. There was seldom a question of whether, for example, a communications system should be developed, but rather *how* it would be designed and *who* would be involved in the design process. There is a clear parallel between these criteria and those employed in building design.

### Bridging the Communication Gap

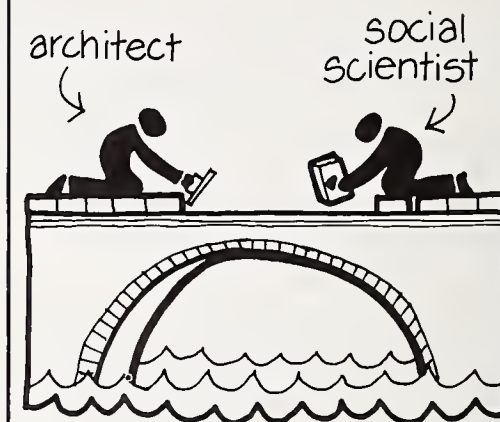

### Conclusion

Poor communication between behavioral scientists and engineers was a major obstacle to smooth operation of design teams. The language barrier was very difficult to penetrate, especially among disciplines with rich bodies of theoretical and pragmatic data to call upon. The question of which language (engineering/behavioral science) to use in communications or, alternatively, the feasibility of devising a new language, became critical issues. This problem was best resolved whenever shared concepts and ideas served as bridges between the disciplines. The need for such bridges in M/E studies is covered in the next chapter.

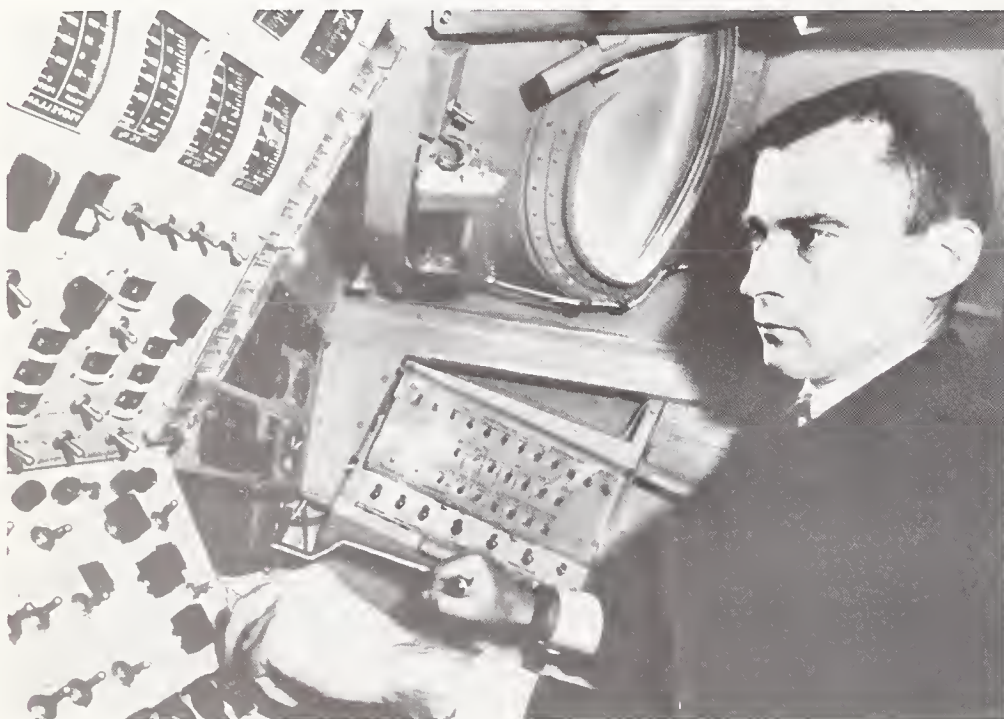

Astronaut at a Console (NASA)



# 3

## Design/Behavioral Research Bridges

### Systems Analytic Approaches

Human Factors/Systems Analysis

Procedures—Task Analysis and Time Budgeting

The Performance Approach

The Performance Approach and Activities

Architectural Programming

Building Evaluation

Design and Scientific Research

Conclusion

*The most striking recent technological advances, although made "visible" by their physical machinery, owe their genesis to a non-physical "intellectual technology"—the application of the new intellectual techniques of systems analysis, simulation, and operations research to problem solving: the Systems Approach.*

*The systems approach has been applied previously in the development of military projects and space problems. It appears to be applicable to urban problems (particularly urban housing) since these, like large-scale space and weapons projects, are complex, require a multidisciplinary approach and involve the organization of technological or quantitative factors.*

*The approach has two main features. First, objectives are stated clearly in performance terms rather than in particular technologies or pre-existing models. The advantage of specifying objectives in systems terms is that it forces decision makers to cast the problem in terms so that a rational comparison of alternative solutions is possible.*

*The second feature of the systems approach is its emphasis upon the inter-relationships within a system. The pre-systems method was to divide a problem into more manageable sub-problems, thereby losing those factors which were relationship-based or dynamic. The comprehensive view of the systems approach enables us to trace out the effects of any set of choices and decisions upon all other relevant decisions.<sup>1</sup>*

### Systems Analytic Approaches

Architects design buildings using inadequate behavioral information. At the same time, user studies are being conducted to better understand how buildings influence the activities of their occupants. Yet, the information developed in these studies has had only limited influence on the way buildings are now designed. What is lacking is an orderly framework which links the interests and needs of architects with those of behavioral researchers. The systems analytic approach provides a mechanism to accomplish this goal.

Systems analytic procedures are used by both the behavioral research

and design professions to solve problems. This common heritage is likely to make these procedures acceptable to professionals in each group. Four topics will be discussed which employ the systems viewpoint to solve problems. These topics will be treated separately, but their interdependence will become apparent.

Before going further with our discussion, the word "system" should be defined.

*A system is an organized arrangement in which each component part acts, reacts, or interacts in accordance with an overall design which adheres in the arrangement. It includes all equipment and associated personnel integrated to perform a defined task.<sup>2</sup>*

<sup>1</sup> J. P. Eberhard, *The Performance Concept: A Study of Its Application to Housing* (Washington, D.C., 1969).

<sup>2</sup> C. E. Gustafson, *Pocket Glossary for Personnel Subsystem Development* (Wright-Patterson, 1960).

The earliest extensive use of the systems approach dates from the planning and operations of the military since World War II, and up until the present time. Space programs also have used similar procedures since NASA was established. More recently, law enforcement, industrial engineers and designers, fire protection agencies, as well as architects, have made increasing use of the procedures developed and refined by these other organizations.

Perhaps the most common image that comes to mind when thinking of a system is a command and control center containing an abundance of communications devices—visual and auditory “black boxes” and sophisticated control panels. Such centers have been abundantly employed by the armed forces and have had widespread exposure on television during the various space missions—especially the lunar exploration program. They now serve several functions in buildings.

One such application is described by J. Kraegel (health care administrator) et al. in the design of hospital facilities. They first pointed to the need for approaching design from a systems analytic viewpoint because of the complexity of many necessary activities, their interdependence, and the requirement for all of them to be integrated into a single functional organization.

The authors indicate that their initial assumption was that a health care system should primarily be responsive to the needs of the patient, rather than the staff. Among the first needs identified was for a patient centered communication system. Their rationale for this requirement was that the patient is at the center of a system (the hospital) which *triggers all of the other hospital systems in their provision of resources. The more helpless the patient and unstable his condition, the more essential it is to have these other systems coordinated through accurate and rapid communication. Ill patients need constant availability of people who can help them, people who can interrelate the needs of the patient with the systems, and who can coordinate the systems on the patient's behalf. To meet the totality of patient needs, a communication network for integrating patient care systems must have a scope that provides information transmission both inside and outside of the hospital.*<sup>3</sup>

## Patient Centered Communication System (Kraegel)



<sup>3</sup> J. M. Kraegel et al., *Patient Care Systems* (Philadelphia, 1974).



## Human Factors/Systems Analysis

Systems analysis, as we have seen, was developed in response to needs identified by the military during and after World War II. Analytic procedures were needed to deal with problems, literally on a global scale—maintaining worldwide communications with armies, moving armies, materiel, and armaments to Europe, Africa, and Asia. Another requirement was that the analytic procedures used to man and equip armies had to be equally applicable to the largest and smallest military units. A common approach was required, independent of the scale of the activity (permitting one to examine problems as they affect units with different levels of responsibility). There was the further need to define problems to permit analysis into major component parts, then, to determine how (and if) the parts related to one another. A final requirement was to determine what role each part played in the problem defined initially.

For example, consider again a communications center with the mission of commanding and controlling several army units. In order for this system to function effectively, communications links to all units must be maintained. The communications lines to each unit might be as follows: one *subsystem* is voice telephone, another one, a radio transmission *subsystem* and, finally, a microwave

digital information *subsystem*. Each *subsystem* in turn can be analyzed into the hardware components required and the *tasks* performed by operators of the subsystem. The complexity of this system becomes evident when we consider that each unit must not only maintain contact with the center, but frequently must also be in direct contact with one another.

Of particular importance are the next steps in the analytic process. The *functions* (objectives) of the subsystems are defined (i.e., the reasons that they are required) in terms of **performance**. For example, voice contact

should be maintained between a unit and the communications center. Note that no decision is made yet as to *how* voice communications are to be accomplished—e.g., radio, telephone. In analyzing how a function should be performed, among the important options considered are those concerned with **human factors**. What tasks are people best able to accomplish to optimize system (and subsystem) performance? Systems and subsystems therefore take into account man/machine (man/environment) components and interfaces as well as exclusively manual or automated designs.

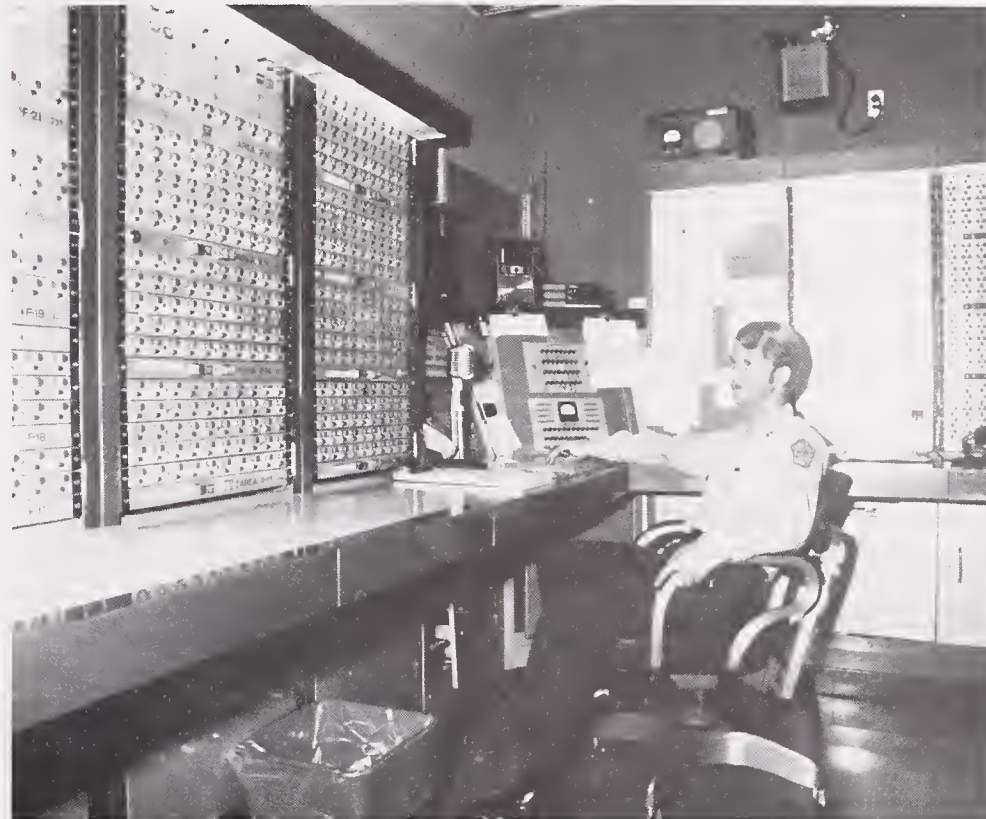

Communications Center (NBS)

A recently completed study at the National Bureau of Standards (NBS)<sup>4</sup> dealt with energy conservation from a systems viewpoint. The report showed that many proposed building energy conservation studies are based on mechanical and/or automated procedures—for example, devices which turn off lights when natural illumination levels reach a given intensity. Yet, available information indicates that the key to significant energy savings may be in the way the building is operated. In summary, buildings should be designed to respond to users in many ways—energy conserving activities being one mode of use.

### Procedures—Task Analysis and Time Budgeting

Task analysis procedures have been employed in human factors studies since the 1940's. While the problems dealt with by human factors engineers were typically those of proper *equipment* and subsystem design, the procedures apply equally to many M/E problems.

<sup>4</sup> A. I. Rubin, *Energy Conservation in Buildings—A Human Factors/Systems Viewpoint* (Washington, D.C., 1976).

**Task analysis** is used to determine the psychological factors essential to adequate performance of a task, according to R. Miller (psychologist). The goal of task analysis is to define the important activities in an operational (or training) situation, as a sound basis for evaluating performance. Another purpose is to modify the way a task is performed, to avoid error and make the job easier. Miller developed a general technique to determine the psychological factors essential to adequately perform a task. This model can be used just as readily to examine activities performed in the home, e.g., the family at dinner.

**Sample Format for Describing Household Tasks**  
(Miller)

Activity	Percentage of Attention
Procedure Following (Recipe)	20%
Continuous Perceptual Motor Activity (Food Preparation)	30%
Monitoring (Cooking) Communicating	25%
Decision Making or Problem Solving (Menu)	20%
Other Non-Task-Related Activity	5%

**Man as a System Component**  
(Van Cott)

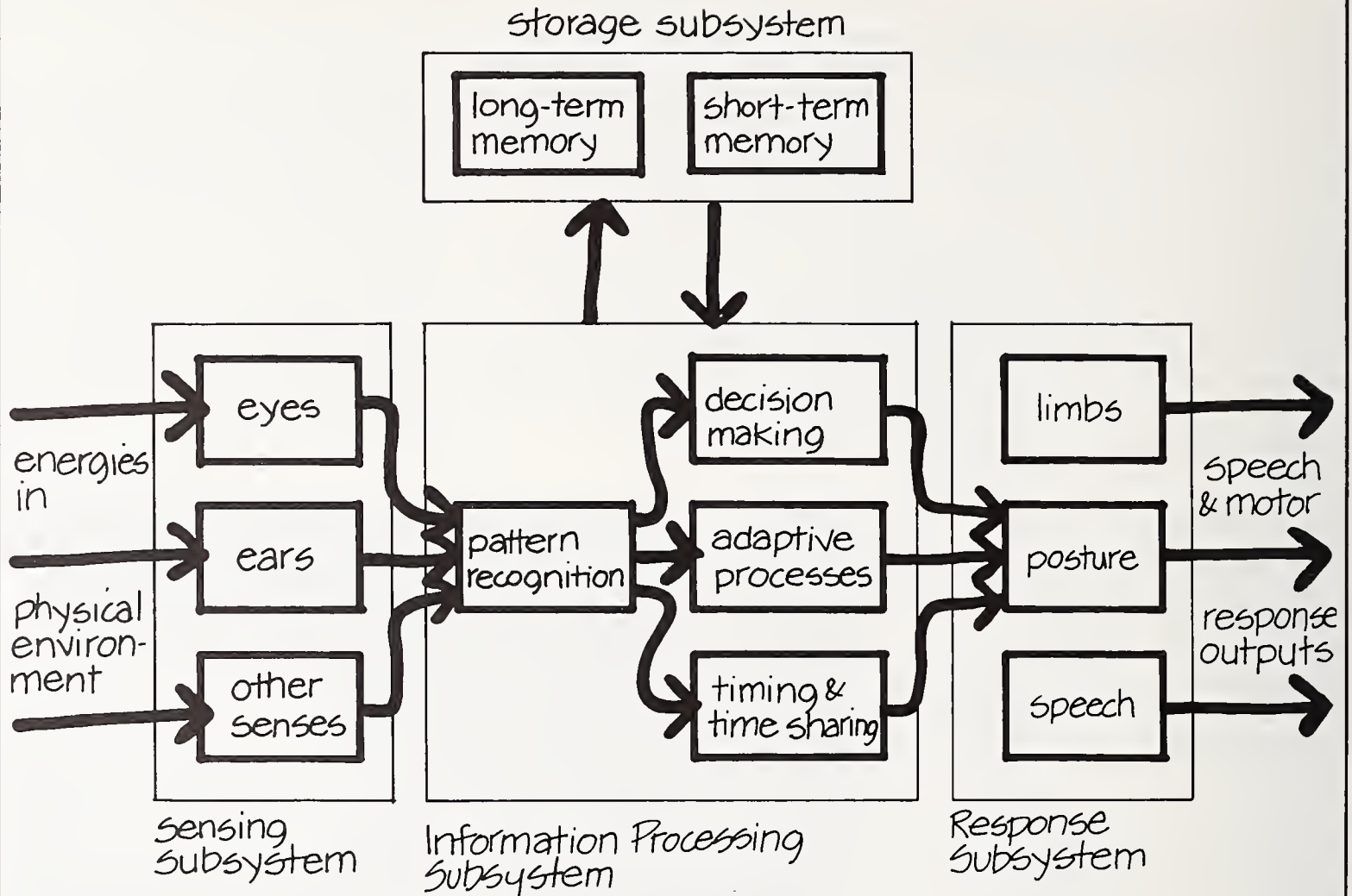

A major attribute of a task deals with time. The duration of a task as well as when it is performed is of importance to the designers of both equipment and buildings. A person preparing food in a cramped kitchen with inaccessible cooking utensils cannot be expected to function effectively. Similarly, if two activities are performed simultaneously, they may well interfere with one another.

Before examining **time budget studies**, let us define the term.

A time budget is very simply a record of what a person has done during a specified period of time—usually a 24-hour day or a multiple thereof. This record is detailed; it lists in chronological order a person's activities

during the period and states either when each activity began and terminated or simply the amount of time spent on each activity.<sup>5</sup>

<sup>5</sup> W. Michelson and P. Reed, "The Time Budget," in *Behavioral Research Methods in Environmental Design*, ed. W. Michelson (Stroudsburg, 1975).



A primary application of data from a time budget study is the collection of information about activities and the time allocated to each. This information provides designers with details about the use of and demand for facilities and services.

In one time budget study, W. Michelson (sociologist) and P. Reed (statistician) sought to determine changes in activity patterns of families moving to either high-rise apartments or single family homes from a variety of other housing types.

### Changes in Selected Uses of Time by Type of Residential Mobility (Michelson and Reed)

Activity	Type of Mobility (percentage)					
	Home to Apartment			Apartment to Home		
	Less Time	No Change	More Time	Less Time	No Change	More Time
<b>Wife</b>						
Visiting (Weekday)	21	58	21	14	64	22
Visiting (Sunday)	19	51	30	25	41	34
Active Sports (Weekday)	2	87	12	4	95	2
Active Sports (Sunday)	5	90	5	6	88	6
Watching TV (Weekday)	33	25	42	41	29	30
Watching TV (Sunday)	33	23	44	23	41	36
<b>Husband</b>						
Active Sports (Weekday)	12	74	13	2	93	5
Active Sports (Sunday)	16	65	19	5	30	15
Watching TV (Weekday)	23	35	42	36	31	33
Watching TV (Sunday)	23	19	58	33	30	37
House Repairs (Weekday)	26	71	3	5	74	21
House Repairs (Sunday)	29	58	13	23	53	25

Let us conclude this discussion with a look at systems analysis and design. T. Ware (architect) examined the design process itself. His work examined the performance concept in design, as an approach which embodied systems analytic procedures.

### Systems Approach and Buildings (Ware)

Problem Definition	Quantitative and qualitative description of what exists and what is desired
Goals	What is necessary to reduce disparity between what exists and what is desired (as above)
Analysis	Developing data on problem, goals, criteria and modeling; indicating elements, relationships quantitatively if possible
Synthesis	Developing alternative solutions
Modeling	Simulating performance of alternative solutions
Criteria	Specification (quantitatively and qualitatively) of goals in detail and priority to determine solution effectiveness
Selection	The solution which best meets criteria
Implementation	Execution of solution—construction of building
Use	Operation, maintenance, repair, alteration of building over time
Feedback	Flow of information from any step to any other step to evaluate adequacy of decisions and improve decision making process in follow-on building cycles

## The Performance Approach

The performance concept has been defined in an NBS report as *an organized procedure or framework within which it is possible to state the desired attributes of a material component or system in order to fulfill the requirements of the intended user without regard to the specific means to be employed in achieving the results.*<sup>6</sup>

The performance approach therefore accepts the premise that the user is the starting point in design. The key to successful design is user satisfaction with the end product. To accomplish this, we must (1) determine the nature of user requirements as a prerequisite for design and (2) be able to evaluate buildings after occupancy to determine whether the requirements were met.

The performance approach was developed as an answer to the perceived failure of the building community to meet the needs for more and better housing. The low rate of application of building-related innovations had resulted in a sense of frustration among those supporting innovative designs. Most building institutions appear designed to resist change. The traditional methods of designing and testing newly proposed building components and materials employ time-consuming, trial and error procedures. After tests have shown innovation to work, building codes must often be modified before

<sup>6</sup> J. R. Wright, "Performance Criteria in Buildings," *Scientific American*, 224 (1971).

## Building Design

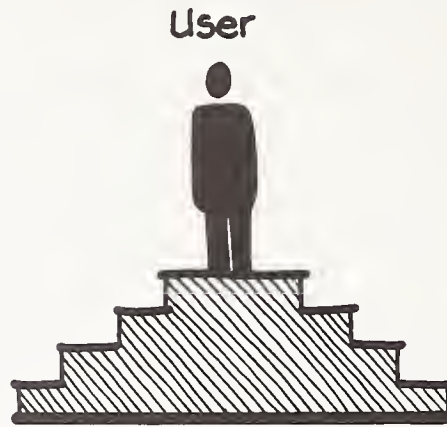

"Successful design has user satisfaction as end product and accepts this as the premise."

builders can apply new techniques. This further extends the time between development of an innovation and its ultimate large-scale use. As a result, many builders, dissatisfied with the status quo, have taken a new look at the methods currently used by building designers. This reexamination has resulted in increased use of the performance concept.

A pioneer of the performance approach in the United States is M. Brill (architect). He has written a number of papers outlining a rationale for writing performance specifications. An examination of this work is useful, not only to understand his system, but also the many alternative approaches.

Performance specifications, says Brill, provide a method of exploring in detail the uses of a building—i.e., its goals. The goals or *objectives* are described first. These goals predominantly take the form of *activities* to be performed by building occupants in an environment with characteristics which enable the activity to be performed properly. The *environmental characteristics* in turn are supplied and controlled by means of *hardware solutions*.

Brill's performance approach requires that the information describing phenomena at each stage of the process be translatable to each suc-

ceeding stage. For example, if we are dealing with a conference room: the *objective* could be to conduct meetings; the *activity* is conversing at a normal voice level; the *environmental characteristic* is acoustic performance. The (partial) solution would be walls with specified transmission characteristics (Sound Transmission Classification (STC) ratings).

Building requirements in performance terms may be conceptualized in many ways. Some theoretical models are static, e.g., the matrix approach; others concentrate on the dynamic features of the design process.

## Building Matrix (after Brill)

Environmental characteristics	usable space	luminaires	plumbing	utilities	food services	windows	security system	communications	space dividers	exterior walls	HVAC	floors	ceilings	sanitation
conditioned air														
illumination														
acoustics														
stability														
durability														
reliability														
safety														
maintainability														
esthetics														
communications														
adaptability														
accessibility														
activity support														
azotic qualities														



## Performance Approach (Caudill Rowlett Scott)

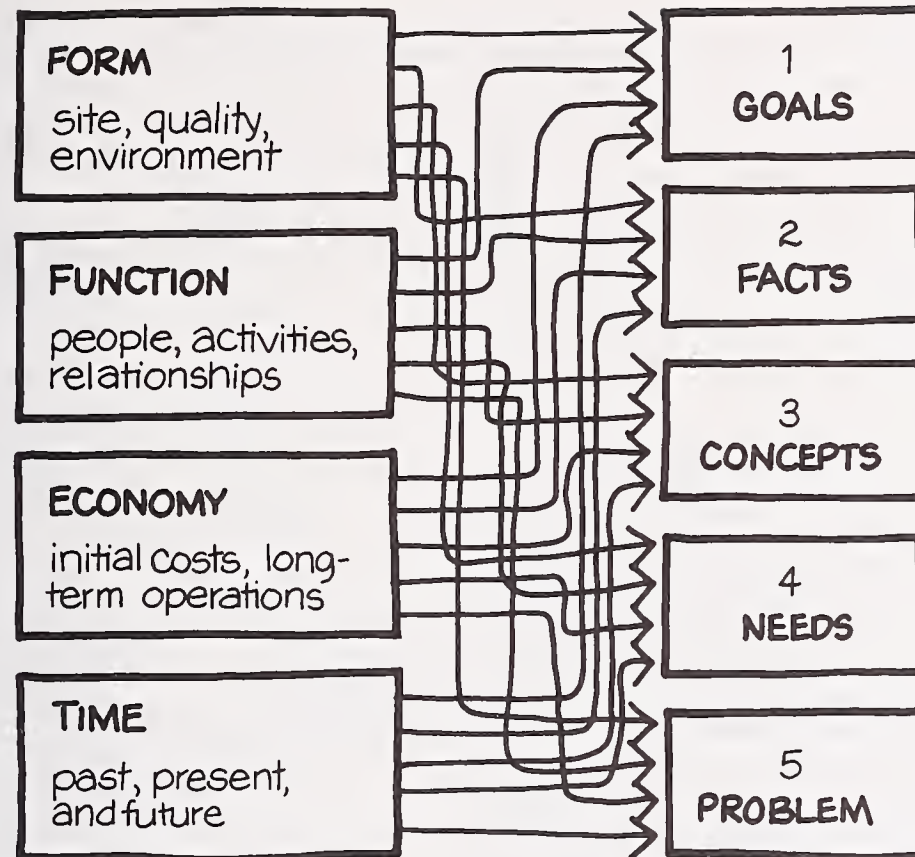

### The Performance Approach and Activities

Activities are a valuable link in a systems approach. They can be related to other activities and further analyzed into components. Activity descriptions enable one to identify relationships with design characteristics—at the scale of buildings and even communities, as well as at the scale of desired features of objects (e.g., light switches).

The architect and client have traditionally identified the activities to be performed in a *building* as an early step in formulating a program. Behavioral researchers on the other hand have examined activities while dealing with *industrial and human factors problems*. (Although terms such as “tasks,” “behaviors” and “work performance” have been used in addition to “activity.”)

T. Cronberg (architect) provides a rationale for employing activities when using the performance approach. While Cronberg's analysis is limited to the activities of the *individual*, this limitation is not inherent in either the performance concept or the concept of activities. Rather, activities involving *social* behavior lend themselves to similar analytic procedures, as may be seen in the work of Barker (chap. 5).

Cronberg notes that activities are a *link between the user and the physical environment*.<sup>7</sup> For example, food preparation (activity) is performed by the individual in a physical environment which must have appropriate attributes (e.g., work space, sink, food storage). She further points out that *activities can be considered as external manifestations of needs*.<sup>8</sup>

### Attributes Concerning Activities (Cronberg)

Activity Variable	Example
Description	General—speak Specific—raise ones hand
Who Performs It?	Individual—age, sex, cultural background Group—family
Requirements to Perform	Space, light, heat
Location	Building type, space within building
Duration, Frequency	How long, how often, e.g., dining, watching TV
Purpose	Why performed—pleasure, work requirement

<sup>7</sup> T. Cronberg, *Performance Requirements for Buildings—A Study Based on User Activities* (Sweden, 1975).

<sup>8</sup> Cronberg

## Activities link the "macro" and the "micro" environment.



The observation of activities formed the basis for a study by H. Proshansky, W. Ittleson, and L. Rivlin (psychologists) of the psychiatric environment of a hospital. They altered the furnishings of a little used solarium to determine the effects of such changes on usage. Before modifications, the solarium was used for solitary activities (sitting alone) and for occasional conversations which took place on a wooden bench. The room was refurnished by adding attractive drapes, furniture and other accessories. After those

changes were instituted, the authors noted that the room was used more intensively. Observations of activities were made by a team of trained observers who recorded activities every 15 minutes throughout the day. Examples of the activities observed and recorded were: sitting alone, talking, standing alone, reading, pacing. Data were also collected indicating where and when activities took place, who and how many individuals participated and how long the activities lasted. On the basis of these data, recommended designs were made for psychiatric institutions.

## Classifying Behavior into Categories (Ittleson, Proshansky)

Behavior	Observational Categories	Analytic Category
Patient sleeps on easy chair One patient sleeps while others are lined up for lunch	sleeping	Isolated Passive
Patient writes letter on bench Patient takes notes from a book	writing	
Patient reads newspaper and paces Patient reads a book	read	Isolated Active
Patient cleans tables with sponge Patient makes bed	housekeeping	
Patient knits, sitting down Patient paints (oils), sitting down	arts and crafts	Mixed Active
Patients play soccer in corridor Patient and doctor play chess	games	
One patient talks to another in reassuring tones Four patients sit facing corridor, talk sporadically Patient fails to respond to doctor's questions	talk	Social
Patient introduces visitors to other patient Patient stands near room with visitors	talk (visitor)	Visit
Patient comes in to flick cigarette ashes Patients go to solarium	traffic	Traffic



An activity analysis approach was used by R. Hester (architect) in several studies. In one study, members of his design team observed and recorded behaviors taking place in a schoolyard. A form was developed as a means of recording the frequency with which activities occurred, and the people participating in them. The data were then analyzed by developing a map which indicated the intensity of use in the various schoolyard locations.

### Site Plan of Courtyard (Hester)



#### Activity Key:

- a walking
- b sitting
- c working
- d bike riding
- e reading
- f running

Hester and his colleagues then combined both features of the earlier schoolyard study in mapping the activities which occurred in a housing project. The activities were precoded, and this information was recorded on a layout of the court area under observation.

The performance approach with the use of activities to describe M/E relationships enables us to integrate behavioral research findings into the design process. This may be accomplished by means of architectural programming.

### Architectural Programming

The American Institute of Architects (AIA) has defined architectural programming as *the process by which criteria are developed for the design of a space, building, facility, physical environment, and for any unit of the environment . . . It is the means through which data about the needs of the ultimate building user are determined and expressed for the instruction of the architect in the development of a design solution . . .*<sup>9</sup>

The AIA publication goes on to state that the program, which is usually in written form, is only a summary statement at a particular time. The program is a process which continues through planning and design and permits new ideas to be tested.

<sup>9</sup> American Institute of Architects, *Emerging Techniques 2: Architectural Programming* (Washington, D.C., 1969).

### Intensity of Schoolyard Use (Hester)



### Major Elements of Programming Process\*

Parts	Characteristics
Client Philosophy and Objectives	Establish the client's goals, attitudes, aspirations, characteristics
Functional Relationships	Relationships between administration, departments, services, traffic movement, personnel projections, equipment needs, etc.
Client Background and Research	Studies to determine community characteristics, economic base, industrial potential, labor market, population distribution, growth projections, etc.

\* American Institute of Architects, *Architectural Programming*.

Programming enables the owner's needs to be defined and translated into specific design instructions. Conflicts must be identified and resolved during the programming stage. The analyses and reports produced during programming are the basis for design. They are the link between the owner's needs and the architect's plans.

A systems approach is employed in developing an architectural program. Several different factors—behavioral, social, economic, engineering, and architectural—are considered in the context of the total system and with an understanding of the activities to be contained within the system. The completed program should indicate the types and amounts of spaces required and how the various spaces relate, one to the other. At this point, the architect can proceed with his design.

## Program Describes Space Needs & Relationships

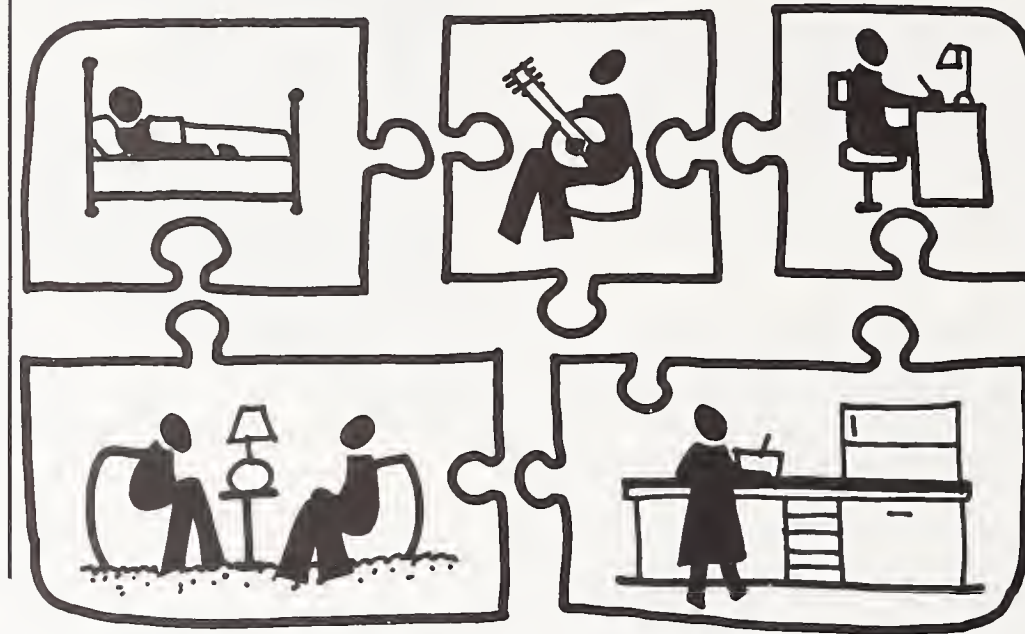

T. Markus (architect) describes the decision process in terms of a series of steps.

- Understanding the problem (analysis)—Includes gathering relevant information—determining relationships, constraints, objectives and criteria. He includes in this phase *the imaginative structuring of the problem.*
- Producing a design solution (synthesis)—Includes bringing experience, intuition and reasoning to bear on the problem to produce one or more possible design solutions.
- Determining the adequacy of the solution (appraisal)—This might be accomplished by employing a modeling procedure. Another approach would be to make measurements on as many relevant factors of the building as possible—costs, space utilization, flexibility. The measurements are then used to make assessments against meaningful criteria, e.g., standards of performance, conformity to constraints, subjective assessments.

## Programming Process

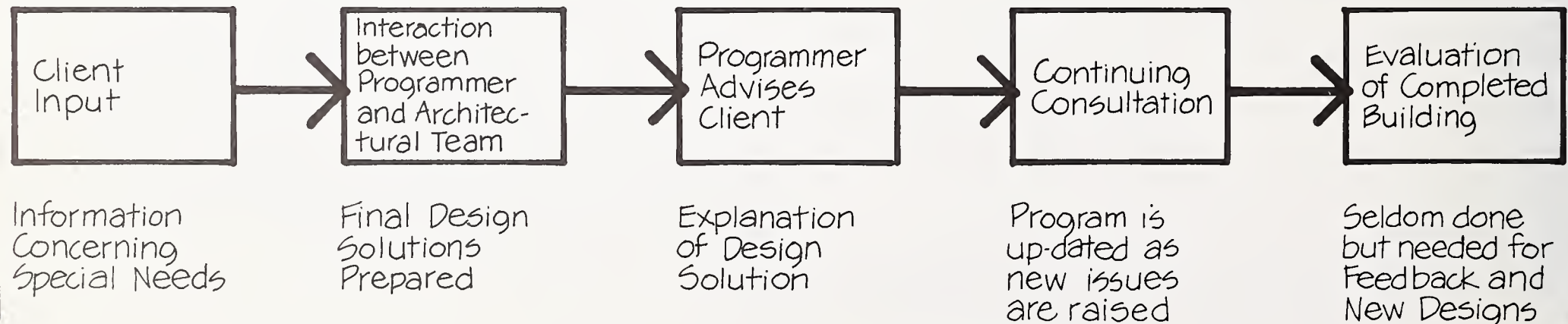



The following steps are described by Markus in developing a typical program:

- **Initial Discussions and Contract Definition**—These meetings would include the team leader or project manager along with architectural analysts, behavioral scientists and special purpose consultants.
- **Identification of Issues**—Initial effort would be undertaken to identify issues requiring further investigation. This effort might involve a tour of the organization, a study of both the formal and informal organizational structure, an identification of the major subsystems within the organization, and some preliminary observational and questionnaire studies.
- **Perform Research**—Behavioral research methods would be used to obtain information on functional and proximity requirements, data on changes in size, past and future growth. Some of this information might be obtained through interviews with top management, personnel department, planning department, operational management, unit heads, junior staff, users, and architects.

### Building Evaluation

An integral part of programming and one which is often neglected is the evaluation of the completed project. According to the American Institute of Architects, there are four possible reasons for such a post occupancy or post construction evaluation. The *first* would be to modify or correct an existing building. The *second* would be

to provide guidelines for future construction of the same building type. The *third* would be to evaluate programming criteria and design effectiveness. *Finally*, it could provide data on how people use and respond to the built environment.

Brill sees the two basic aspects of building evaluation as (1) gaining information about the usefulness of buildings, and (2) using that information in the design and use of new buildings. He says that evaluation is the first stage of a process which is over only when information is fed back in a useful form to those making later design decisions. He further points out that evaluation must be an integral part of the total design process.

The assessment of buildings requires a coordinated effort by all of those who participate in design—clients, users, architects, engineers, and social scientists. The complexity of building evaluation is illustrated by the following description of the experiences of Cooper and Hackett with this problem:

*At first we intended to interview the designers to find out about their views on user-needs and how they provided for users in their designs. But in the course of these interviews, it became apparent to us that many other people in addition to the designers are active in the design process of developments such as these; it is not only the architects' ideas about user-needs which are expressed in the end-product, but also those of the sponsor, the government lending agency, and many others. Thus, from a simple ex-*

*amination of 'architects' assumptions about 'user-needs,' our study expanded into a consideration of the whole design process and of the many 'actors' and constraints that entered into it.<sup>10</sup>*

A major difficulty with past evaluations is that they concentrated on general attitudes and preferences of respondents to environments, without adequately specifying the design characteristics of the building being evaluated. Consequently, it is difficult to determine the relationship between how people respond to buildings and the particular design features of the buildings. The design implications of the investigations cannot be readily determined. An evaluation, if it is to be useful, should enable changes to be made to improve building performance, or at least to provide information which can improve the design of and/or evaluation of other buildings. Regardless of its use, evaluation is valuable only if the basis on which decisions are made can be traced and examined.

To summarize, Brill says, *programming can be thought of as goal setting with an implementation plan. Post occupancy evaluation is a means of learning how well the plan worked in practice and the extent to which the goals were achieved.<sup>11</sup>*

<sup>10</sup> C. Cooper and P. Hackett, *Analysis of the Design Process at Two Moderate-Income Housing Developments*, Working Paper No. 80 (Berkeley, 1968).

<sup>11</sup> M. Brill, "Evaluating Buildings on a Performance Basis," in *Designing for Human Behavior: Architecture and the Behavioral Sciences*, ed. J. Lang (Stroudsburg, 1974).

## "Tool Kit" of Evaluation Methods

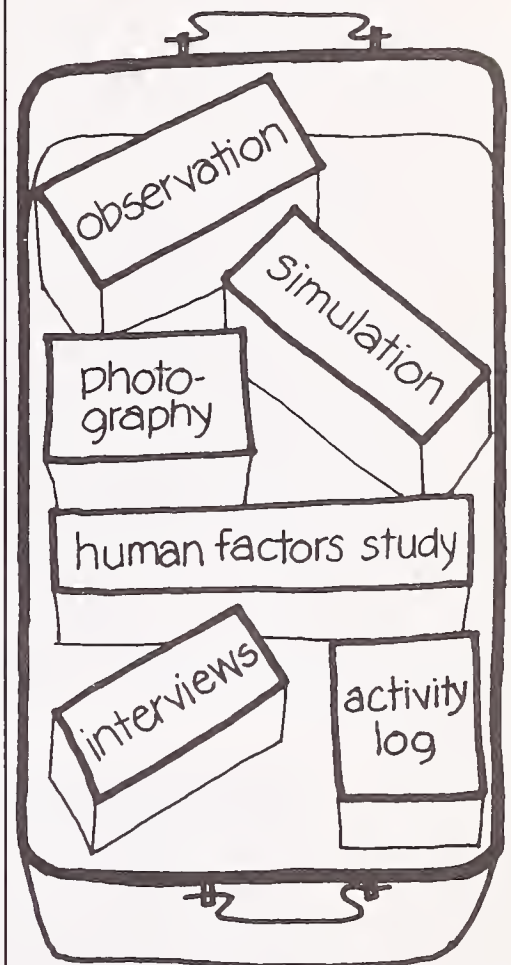

### Design and Scientific Research

Research and architecture share a number of features. Building design has been examined from a research viewpoint by Markus and P. Levin (British researchers). They point to the similar procedures used by architects engaged in design and researchers who plan and conduct investigations.

Markus assumes that complex relationships exist among various aspects of design: design and costs, environmental factors, user activities, behavior and performance. When making these assumptions, the architect acts in the same manner as a scientist who has experimentally demonstrated a number of relationships. On other occasions, the architect must make guesses about the nature of design and other factors. When such guesses are made, the architect can draw attention to the informational needs to test the proposed design solution. Some of these informational gaps must be filled by means of field studies conducted in actual buildings in use. This is especially true for information on occupant behavior and activities. Every building therefore can potentially be used to test a research hypothesis.

Markus indicates that a testable conceptual scheme (model) is required if design concepts are to be tested. A symbolic representation of the concept (diagram, drawing, scale and mathematical models) is required. The model enables design (independent) variables to be altered so their effects or consequences are evident (dependent variables). (The completed building is the most detailed representation of the concept being explored.) He urges the development of building design models which include aspects which are capable of measurement. Once we can quantify, we can reduce the scale of the model (e.g., length, area) and make tests.

Levin also dealt with the relationship of design and scientific research. His conceptual model is like the traditional one of scientific research, designed to understand cause-effect relationships. He defines building design as being a set of "controllable causes." A number of "controllable effects" can be attributed to these design features. For example, in the design of a high-rise building, the elevators permit people to move from floor to floor. The elevator is a design feature (controllable cause/ independent variable) without which people could not travel vertically (controllable effect/dependent variable) in the building. However, only a limited number of behaviors (activities) can be explained in terms of controllable causes and effects, because of the multitude of uncontrolled factors (causes and effects). Returning to

our illustration, people may be unable to use elevators at times due to power outages caused by emergencies (cause-related) and because of individual preferences (effect-related).

## Conclusion

The analogy between science and building design by Markus and Levin appears questionable. We are more comfortable with the concept of design as the creative application of scientific, engineering, and other principles. On the other hand, we believe that scientific research is needed to improve the M/E information available to the architect. In the next part of the study, we will discuss in greater detail the relationships between scientific research and building design.

## Design/Research Similarities (after Markus)

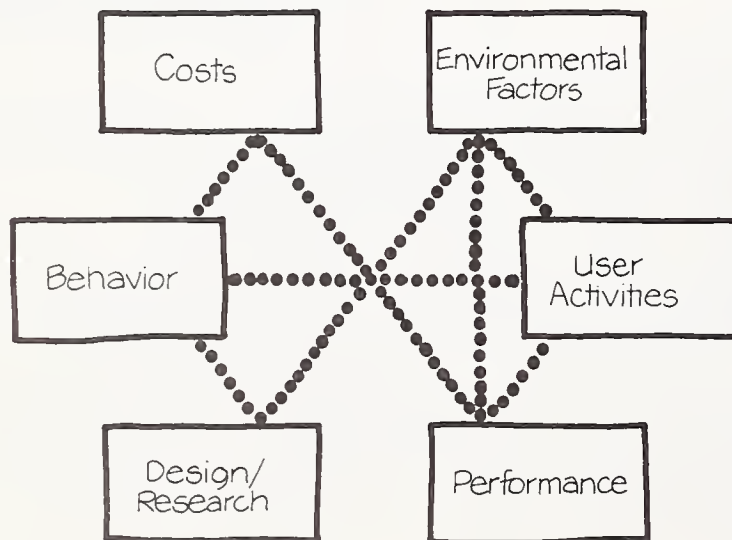

## Design Process (Levin)

Process Step	Example
1. Identify parameters	Lighting, acoustic needs
2. Identify dependent variables	Seeing, hearing, privacy
3. Identify relationships	Windows as sources of light, sound
4. Identify constraints	Building code regulations
5. Determining parametric values	Lighting level needs
6. Compare possible solutions	Examining a series of tradeoffs—e.g., windows, balancing lighting, privacy and auditory needs



## A Conceptual Model (Cronberg)

User Activities as Basis for Design

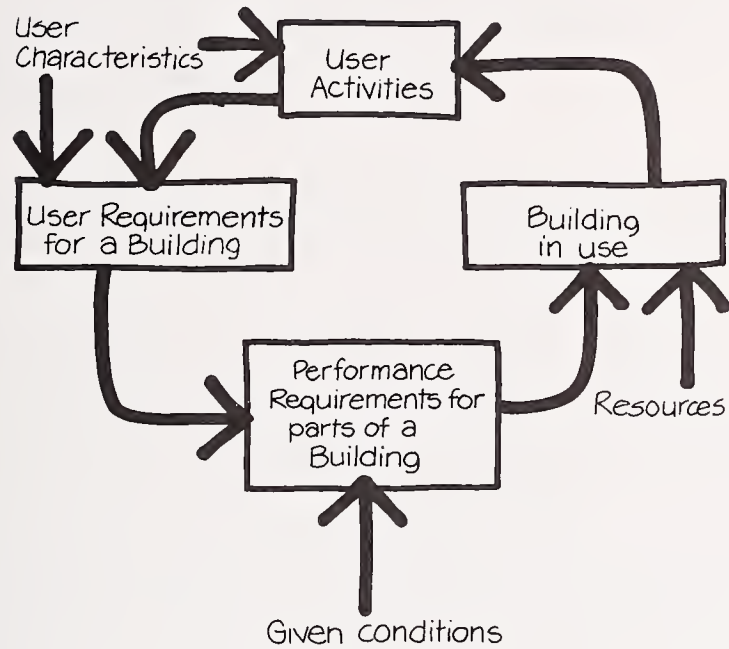

## Building Systems and a Subsystem Analysis

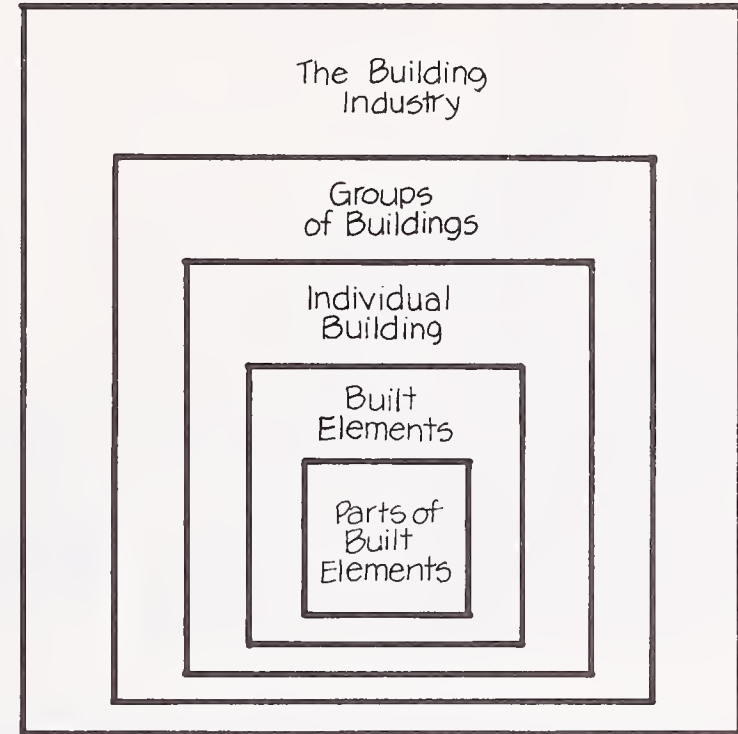

## Development of System over Time (Markus)

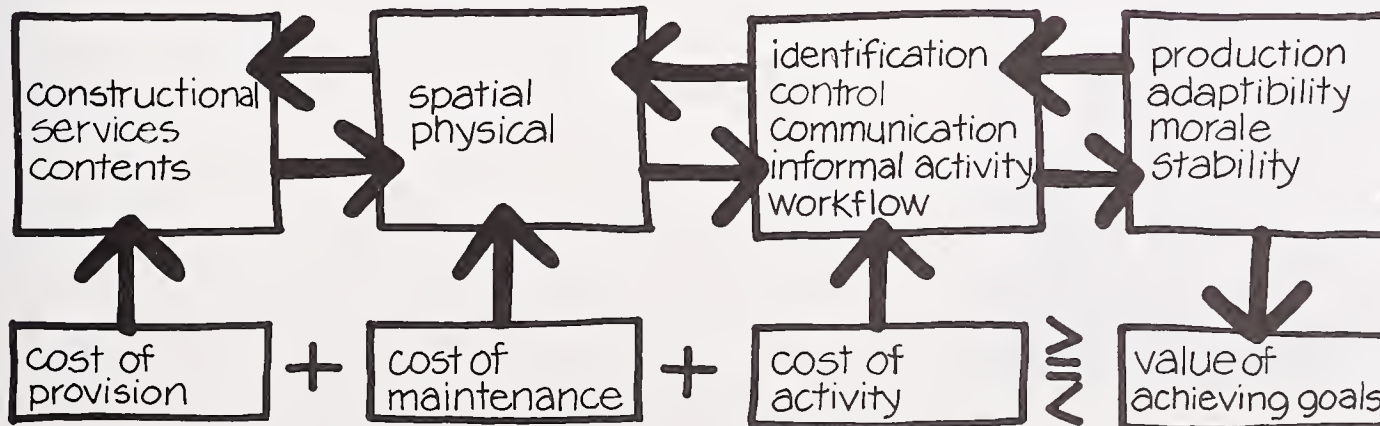

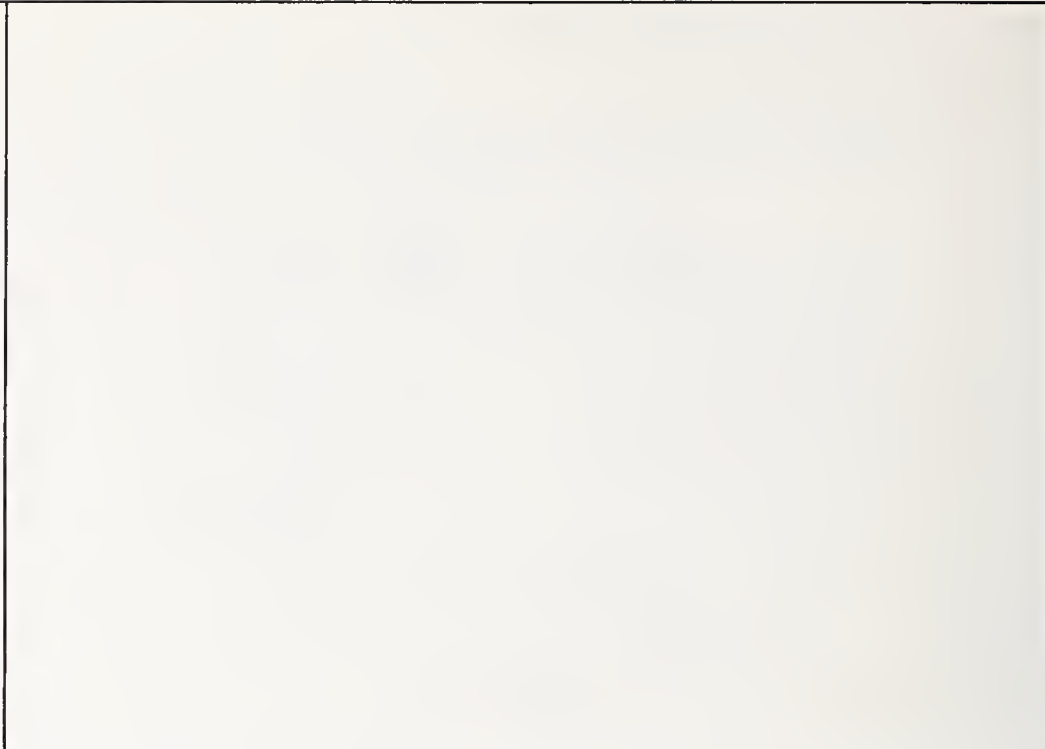
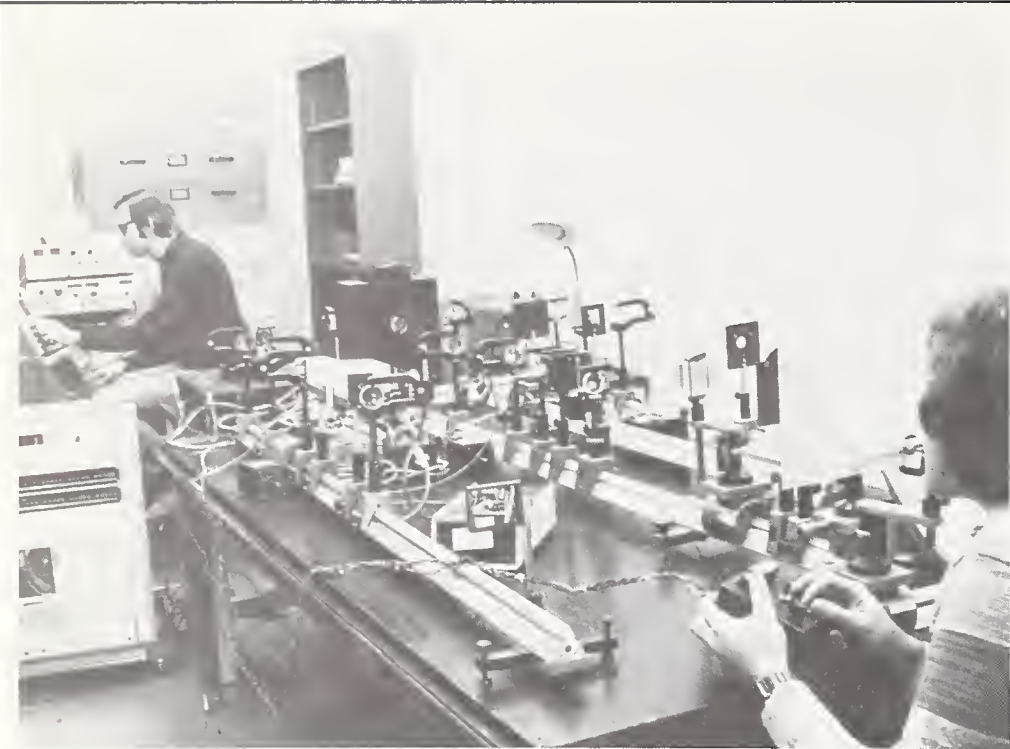



# Part II

---

## Research Approach and Identification of Subject Areas

This part of the study is concerned with the need for M/E researchers—whether behavioral scientists or architects—to develop standardized procedures and terminology when they define and attack problems of common interest.

Chapter 4 provides an overview of scientific research to familiarize those with limited information in this subject area. It explores the traditional functions of research and describes in some detail the procedures used to plan and conduct experiments and analyze research findings. The major emphasis is the need for experimental controls when making observations and measurements if research findings are to be relevant, useful and reliable.

The two preceding chapters deal with research approaches used in most scientific disciplines. Chapter 5 deals with the application of these principles in M/E settings. The emphasis is on *how* observations and measurements of human behavior are made in building environments. Several of the most widely used research methods are described and compared. In later parts of this work, we will describe in some detail how the methods are used to solve a variety of M/E problems.

Chapter 6 describes the range of problem areas which require attention by a M/E discipline. The subject matter of interest to architects and behavioral scientists is suggested by illustrating the many “scales of observation” necessary to obtain M/E information. Traditional scientific disciplines are then described from the standpoint of being potentially valuable resources in terms of experimental approaches as well as repositories of relevant and important M/E information.

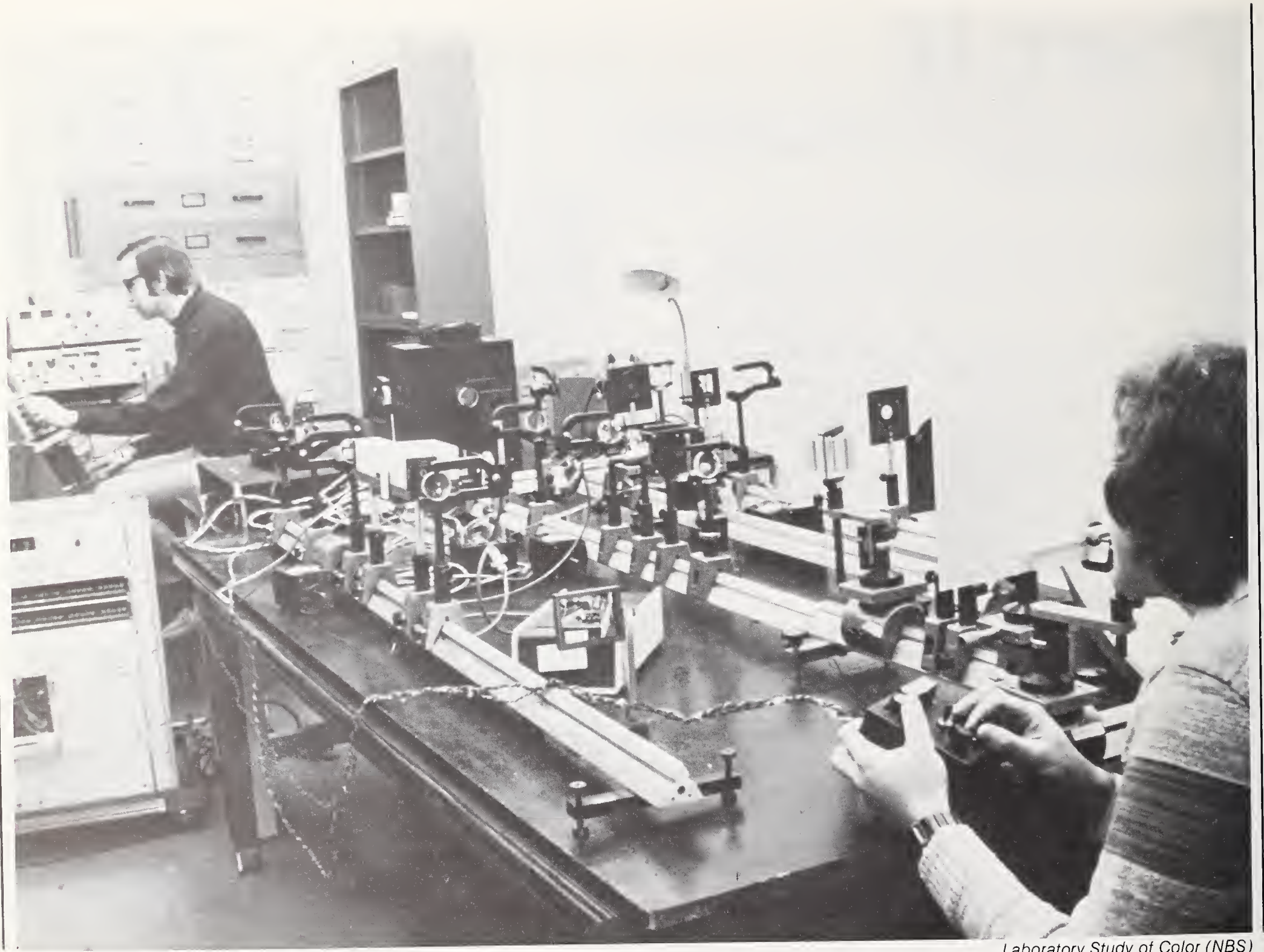

Laboratory Study of Color (NBS)



# 4

## Scientific Approach

### Research Functions

Basic

Applied

Methodological

### Experimental Research

### Research as Information Development

### Research Approaches

Analytic

Multivariate

Multivariate and Parametric Compared

### Criteria for Evaluating Research

### Objectivity and Research

### Research Controls

### Conclusion

*Every science has its own methods of investigation. Since every science is characterized by the nature of its problems and by the variety of phenomena all progress is measured by improvements in the means of investigation. The whole future of experimental medicine depends on creating a method of research which may be applied fruitfully to the study of vital phenomena. Experimentation in this area is harder than in other sciences, but for that very reason, it is indispensable. Every time that a new and reliable means of experimental analysis makes its appearance, we invariably see science make progress in the questions to which the means of analysis are applied. In a word, the greatest scientific truths are rooted in details of experimental investigation which forms the soil in which these truths develop.<sup>1</sup>*

If the architect is to have accurate and useful information describing the relationships between building design and occupant behavior, past experience in other fields points to the need to use the scientific approach to develop the required data. M/E problems might differ from those attacked by the classical disciplines of physics and chemistry, but the need for careful observation and measurement procedures to obtain objective, reliable, quantitative information applies to all subject areas. First, let us consider what we mean by the term **scientific approach**.

This chapter introduces the language and techniques of science with a number of basic concepts.

With few exceptions researchers assume that the world is an orderly place and that by carefully collecting information in a systematic way, i.e., by experimentation—we learn about phenomena under investigation. Data, however, are collected in the context of developing and refining predictive models, which are then tested by researchers. As C. Bernard (French physiologist) notes:  
*To be worthy of the name, an ex-*

*perimenter must at once be a theorist and a practitioner. While he must completely master the art of establishing experimental facts, he must also clearly understand the scientific principles which guide his reasoning through the varied experimental study of natural phenomena.*

*Of necessity we experiment with a preconceived idea, an experimenter's mind must be active, i.e., must question nature, put all manner of queries to it according to the various hypotheses which suggest themselves.<sup>2</sup>*

The researcher thinks of himself as a member of a community of scientists who, although scattered in time and space, consider their work as a *cumulative* understanding of a phenomenon. That is, although each scientist would like to make a unique contribution to the growth of information in a subject area, an awareness exists that the work of one researcher builds on that of another who will use that research to explore even further. Better understanding comes from the combined efforts of many scientists using similar research methods to collect data designed to minimize measurement errors and increase objectivity.

<sup>1</sup> C. Bernard, *An Introduction to the Study of Experimental Medicine* (New York, 1957).

<sup>2</sup> Bernard

## Research Functions

Our discussion thus far has dealt with research rather abstractly, as a means of obtaining information in a systematic way. Research consists of techniques used to solve problems. First, let us consider how research is categorized.

### Basic

Fundamental (or basic) research is used to determine why materials or people behave as they do. Theoretically the basic researcher is not concerned with the potential application of findings, or whether in fact they have any. (In practice, problems being researched are often defined with applications in mind.) The pursuit of basic research should not be bounded by time—we always have more to learn. The research process is such that when one question has been answered, more questions inevitably are raised. This in turn leads to more research.

With respect to M/E studies, many problem areas are basic, e.g., Sensory Research—How do we perceive our environment? Why do we see (hear) as we do? How do the senses interact with one another to produce a unified experience? What is the effect of past experience on perceptions? How do our life experiences affect our judgments of the environment?

Since researchers try to understand *why* people respond to environmental characteristics as they do, they seek a fundamental explanation of behavior—one which can be explained by bodily structures or processes. The development of this type of information has practical as well as theoretical implications. For example, we know that a sizable proportion of the population is color-blind and that red-green color blindness is more common than other kinds. Since traffic lights employ these colors as signals, the inability to distinguish between the colors has handicapped many actual (or potential) drivers. Once researchers better understood the nature of red-green color blindness, the signal problem was solved by modifying the colors of these lights enough so drivers with this problem could distinguish between the lights, using the color discrimination that they do have, i.e., blue-yellow.

## Scientific Approach

(After B. F. Skinner)

Scientific Attribute	Description
Cumulative understanding	Work of one researcher builds on others
Set of Attitudes	Deals with facts, not opinions about facts  Willingness to accept facts, even when opposed to wishes
Willingness to remain without answer	Avoidance of making premature judgments
Search for order, uniformity, lawful relationships	Begins with examination of single events, moves to general rule.  Experience leads to clearer, more precise relationships between events
Prediction of events	Awareness of arrangements of conditions based upon a system of cause—effect relationships

### "Community of Scientists"

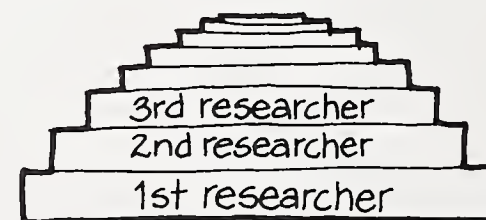

The work of each researcher forms a basis for the work of the next researcher.



## Applied

Unlike basic studies, applied research is not open-ended with respect to the questions being asked, or the time available. In many instances, instead of the researcher defining the problem to be studied (as in basic research), the problem is partially defined for him. That is, research is conducted because a person (other than a researcher) has identified an actual (or potential) problem which requires information to solve. Most M/E studies fall into this research category. Such experimentation is designed to answer a highly specific question concerning a particular environmental characteristic, e.g., the acceptability of a given color scheme by office occupants.

## Methodological

Researchers, whether engaged in basic or applied investigations, rely on standardized procedures (methods) to make observations. The type and quality of the findings (as well as the ability to quantify them) depend on the characteristics (particularly limitations) of the measurement instruments and procedures used.

A major research activity is therefore the improvement of experimental methods. In M/E studies, this is especially important because many techniques now used by researchers were designed for other purposes. Research serves several functions—all important if we are to progress in the development of a M/E discipline.

## Experimental Research

The researcher's goal is to solve a problem by conducting an **experiment**. An experiment is no more than the arrangement (or recording) of a set of conditions which permits the collection of information in a systematic way.

**Data** constitute the records of observations and measurements as well as a description of the circumstances surrounding the collection of information. The essence of research is to know which are the appropriate observations (and *how* to make them).

## Options with Consequences for Research (Michelson)

### The Option of Seeing:

1. Behavior as actions or as acts.
2. Man in terms of aggregates or as an individual.
3. Man as a whole or as an abstract part of a social system.
4. Man as the prime client or as an object of investigation.
5. Environment at an aggregate or at a nonaggregate level.
6. Environment as an objective or as an experienced structure.

### The Option Between:

7. Direct or indirect measurement of environment.
8. Man or environment as the primary sampling unit.

## Research as Information Development

Research is also a means of developing required information using standardized procedures. This process ranges from a straightforward compilation and evaluation of existing information to the need to develop new techniques. In either event, the starting point of research is the identification of a problem (even if it cannot yet be readily defined).

The following illustration shows how a research problem might be attacked.

Assume the problem is to determine how to direct the visitors of a high-rise building from the building entrance to their destination with minimum confusion.

First, we may want to pose the question in different terms. For example:

- How much information is required to minimize potential problems?—i.e., level of detail.
- What is the nature of the information required to enable visitors to reach their destinations?
- In what form(s) should the information appear?
- Should information be repeated, or be provided in several forms?—i.e., redundancy.

The researcher often would like to obtain first-hand information concerning the problem. One approach is to identify a horrible example. That is, to find a building where people have difficulty getting to their destination. This approach would provide the opportunity to observe the types of problems, and to question visitors with problems, thereby gaining greater insight for follow-on activities.

## Main Forms of Data Collection Responses (From Galtung)

	Non-Verbal Acts	Oral, Verbal Acts	Written Verbal Acts
Informal Settings	Participant Observation	Conversations Informants	Letters, Articles
Formal-Unstructured Settings	Systematic Observation	Interviews, Open Ended	Questionnaire, Open Ended
Formal-Structured Settings	Experimental Techniques	Interviews, Precoded	Questionnaire, Structured

Assume that a literature review and site visit provided sufficient information to pinpoint the nature of the problem. We have found that the signs in buildings are the major source of confusion; if they could be improved the problem would be solved. Our goal therefore is to determine how to provide better directional information.

Once the problem has been identified in general terms, a literature review is conducted to determine the availability of possibly relevant information. In its most accessible form, the necessary information would be included in a single source document—if such a publication were available. In the present case, we would be looking for recommended signs to be used in buildings for directing people from place to place. The behavioral researcher, however familiar with similar problem areas (e.g., human factors), might find that the information had already been developed in a different context. For example, similar problems are encountered aboard ships, and research findings developed for the Navy might apply to our problem. The task then is to determine the relevance of existing data to a particular design situation. (Training and familiarity with measurement procedures would help the researcher decide whether the shipboard information applied to the high-rise building.)

## "Literature" Search - Informational Sources

	OLD	NEW	
General	"Secondary Sources"	"Primary Sources"(written)	Current Materials
<ul style="list-style-type: none"> <li>• Books</li> <li>• Magazines</li> <li>• Newspaper</li> <li>• Media presentations (television, movies)</li> </ul>	<ul style="list-style-type: none"> <li>• Textbooks</li> <li>• Academic training</li> <li>• Experience</li> <li>• Books and Magazines on topic (or related topics)</li> </ul>	<ul style="list-style-type: none"> <li>• Technical Journal articles</li> <li>• Papers presented at meetings</li> <li>• Review of Government and Private Publications</li> <li>• Summaries of ongoing research</li> <li>• Subject Bibliographies in print, developed</li> </ul>	<ul style="list-style-type: none"> <li>• Personal contact with researchers</li> <li>• Laboratory/Field visits to ongoing studies</li> <li>• Round table discussions</li> <li>• Review of studies being planned</li> </ul>

We have said that a key factor is the characteristics of those who will occupy the building being designed. If it is to be for the elderly, the information must be used as a basis for design applicable to them. We should consider that elderly people do not see as well as others. Therefore, lighting levels may have to be increased and/or the lettering on signs may require enlargement. Frequently, experimental data does not apply to the aged because most of it has been obtained from measurements of healthy young adults—college students, young researchers and members of the military.

In sum, the search for information of direct or indirect relevance to a problem may lead to a dead end. If this were the case, we would conduct an experiment to develop the required data. Our first task would be to formulate a research hypothesis—i.e., to pose a question in a way that it could be answered by means of an experiment.

To minimize the time and expense required to collect new information, and ensure the quality of information, it is best to use proven research methods.

When research must be performed, the most direct approach uses a *standardized* technique for making observations. By standardized, we mean that other researchers have identified and solved many of the potential procedural problems. We can therefore have confidence in our findings. For example, we could develop a questionnaire asking people to judge which of several possible messages should appear on a directional sign. The development of such a questionnaire can be straightforward, based on the considerable information already available. (See chap. 20 for details.)

We may determine that a questionnaire would not suit our purpose because the results would only indicate a *preference*. Maybe people cannot judge in advance whether one message is actually *more effective* than another one unless faced with the actual situation (or a simulation of it). In this event, an alternative might be preferable, for example, to modify a standard technique developed for another purpose. One such approach would be to ask experimental subjects to participate in a game, based on the mapping procedures employed by Lynch and others (see chap. 6). We would instruct subjects to chart a path (on a predrawn form) from one location to another. Information could be supplied to the subjects using different written instructions, color and other coding devices, or combinations of written and coded information. We would then estimate how long it would take to arrive at the destination; how many errors were made, etc.—based on performance in the game.



## Acquisition of User Information (Availability of Data).

Level of Difficulty	Accessibility and Status of Information	Accessibility and Status of Methodology	Data Collection Approach	Required Know-How
1	All data available in usable form	(Not applicable)	Apply existing data	Ability to specify data requirements
2	Some data available, modification or additions needed	Methods available, not required	Start with existing data and modify by interpretation, extrapolation, etc.	Recognize similarities between available data and needs; ability to judge <i>what</i> is needed and how to obtain it
3	Little relevant data available	Methods available to generate required additional data requirements	Collect data using standard methods	Specify informational requirements, plan and conduct research meeting these needs
4	No relevant information available	No methodology directly applicable	Modify existing methods if possible, or innovate completely	Sophisticated research background, insight into design problem

Thus far we have considered efforts to locate available information, or to use or modify standardized methods to obtain information. In both instances, one can take advantage of information or techniques developed by disciplinary experts. This brings us to the worst case situation where neither the information nor appropriate standardized measurement techniques are available. Measurement methods would therefore have to be developed.

In our illustration, we would then have to use our instincts and judgment on a trial and error basis. One approach might be to give a time-stamped ticket (including entrance location) to people who enter the building. Then, on arrival at their destination, the ticket would again be time stamped, the visitor would be asked to indicate the path used, and any problems encountered en route. The data could be compiled by means of a map and a questionnaire. This approach would be termed a **pilot study**. This would be evaluated and the procedure modified as needed, if it seemed promising.

The development of innovative research approaches is a major challenge to any researcher. The techniques devised must be appropriate to the problem and defensible to the scientific community in terms of scientific controls, procedures and relevance. It is frequently difficult to meet these objectives because a new methodology does not have the advocacy of researchers who have already used it, are aware of safeguards, and are satisfied with the result. Instead, it may encounter a high degree of scientific skepticism because of potential problems and biases inherent in all research procedures.

## Modification of a Standard Research Approach

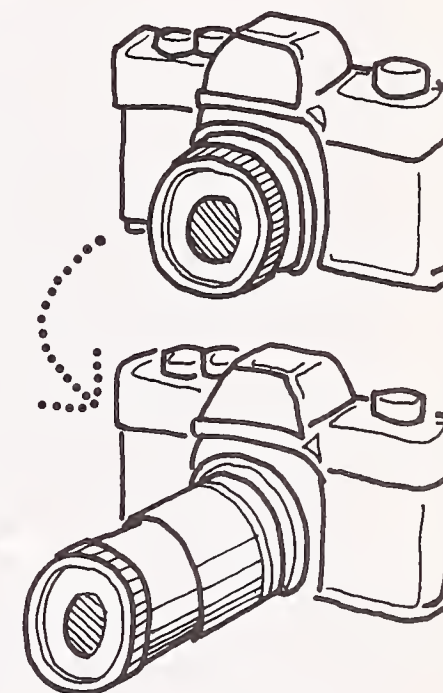

# Matrix of Possible Independent and Dependent Variables Relevant to Human Factors Aspects of Living Environment (McCormick)

Dependent Variables (criteria)	Independent Variables															
	Building Characteristics			Physical Environment Characteristics			Ambient Environment Variables			Community Characteristics			Services, related facilities			
	1	2	etc.	1	2	etc.	1	2	etc.	1	2	etc.	1	2	etc.	
Performance of activities																
Physical convenience																
Convenient mobility																
Health and Security																
Physical comfort																
Physical space																
Social interactions																
Aesthetic values																
Personal values																
Financial considerations																

## Research Approaches

M/E researchers have a number of techniques available for their investigations. Approaches range from traditional **analytic** investigations, often conducted in laboratory settings, to multivariate field studies using questionnaire surveys and observational techniques. Finally, various simulation methods have been developed as an additional means of collecting M/E data. These methods will be described in detail in the following chapters of this work.

## Scientific Procedures

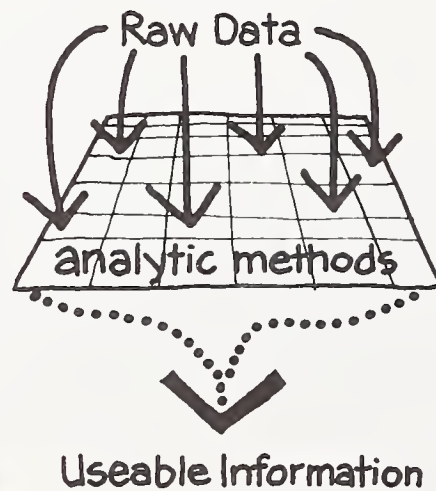

## Analytic

Scientists using traditional research methods rely on analytic procedures in their work. Phenomena are examined in a way that permits the researcher to identify and measure the component parts (elements) of whatever is under investigation.

Research is not performed in a vacuum; it occurs in the context of a scientist speculating about what is likely to be found—e.g., a theoretical model. For example, visual scientists, on the basis of known findings, believed that the eye had two different classes of visual receptors, one for normal viewing, the other for reduced visibility. Physiological researchers then sought (and found) two different types of cells (*rods* and *cones*), which accounted for the known results.



Once rods were identified as the cells used for reduced visibility, further analyses revealed that chemical actions occurred in the presence of light, and, more specifically, that the chemical **rhodopsin** was thought to influence dark adaptation. A refined conceptual model was then developed, based on the hypothesis that dark adaptation can be explained in terms of the amount of rhodopsin available to the rods in the eye. That is, the level of dark adaptation of an experimental subject can be predicted by determining the rhodopsin level (and vice versa). Experimental findings then verified the cause/effect relationship between the presence (in appropriate quantities) of a bodily chemical (rhodopsin) and dark adaptation. This process illustrates the classical (traditional) research approach.

Analytic research in a laboratory is typically performed in a way which permits the scientist to examine one variable (**parameter**) at a time while maintaining control of all other extraneous variables. This is frequently termed **parametric research**. Parametric research consists of the systematic manipulation of one variable (**Independent**), and making measurements on another variable (**dependent**) thought to be directly influenced by the independent variable, while keeping all other conditions constant by means of **control** variables.

For example, a researcher may want to determine the effects of lighting levels on reading ability. One way is to keep all conditions within a room constant (*control* variables, such as noise, temperature, characteristics of subjects) except for illumination levels. By using three different levels of illumination (*values of the independent variable*), one might evaluate the ability of subjects to read. The *independent* (or response) variable could be the ability to answer questions correctly about a passage which was read for a given time, e.g., 10 minutes. The reading test scores associated with the three levels of illumination make up the "raw data" of the study. If the test is an adequate measure of reading ability, the data, when analyzed, will indicate whether the different illumination levels used in the study had any effects on the reading (and comprehension) ability of the students.

### Parametric Study

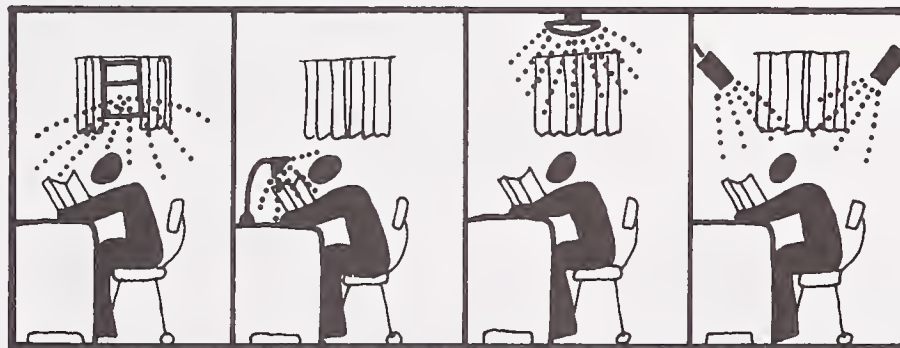

natural      direct      overhead      peripheral

Systematically manipulate one (independent) variable — such as lighting — and make measurements on another (dependent) variable — such as reading speed — while keeping all other conditions constant.

Thus, parametric research enables scientists to examine the effects of one variable on another while maintaining control of all other factors. (In fact, it is virtually impossible to be aware of, much less control, *all* factors, but those not controlled are theoretically not expected to influence the research findings.)

For research areas which have been investigated for many years, the parametric approach is feasible because, for the most part, the pertinent variables are to some extent known. That is, the researcher knows which variables should be manipulated, controlled and measured.

This is not always true, however, especially in M/E studies.

### Multivariate

In many situations, identifying one or even a restricted set of variables is difficult—especially in the case of behavioral studies of building environments where many physical and personal factors are present. The activities occurring and the complexity of the situation make it more difficult even to formulate hypotheses for study. Such investigations are known as **multivariate**. The first task of the researcher under these circumstances is to develop insights into the situation under study. Consider a school design.

### Multivariate Study

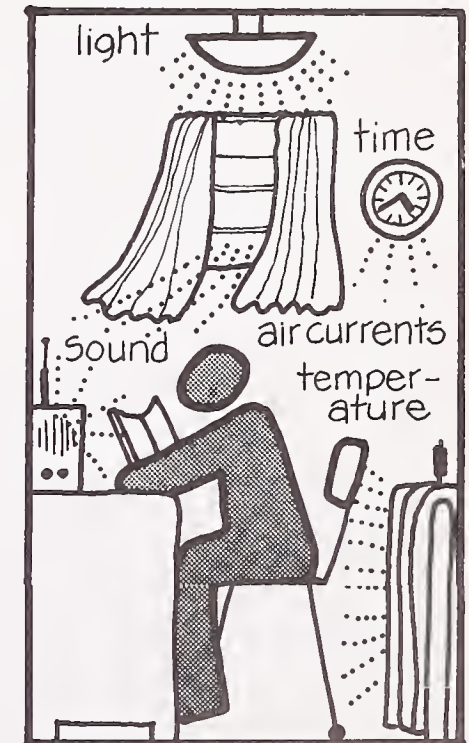

Take into account all possible independent variables in measuring the dependent variable.



Many new schools contain a multi-use space as a meeting room, gymnasium, auditorium and exhibition hall. The classrooms also are designed to accommodate several activities simultaneously—one group of children may be reading by themselves while another group is reading aloud to the teacher. Activities in a room also change from time to time. Participants may vary considerably—children use the room during daytime while adult activities go on in the evenings. A researcher encountering this degree of complexity may be overwhelmed by the multiplicity of variables.

The first task is to define the problem. In this case, it is to design the multi-use space to best perform the desired activities. Then, it would be useful to narrow the scope of the problem. One way to do this is to determine what features of a complex situation can reasonably be ignored. Once this is accomplished, we can more readily focus on important variables.

In the example of the multiple-use school gymnasium, three variables may be identified and explored by researchers.

- The time of day when the activity was performed.
- The age of the participants.
- The nature of the activities.

Field researchers often use two techniques to better define problems—one based on questionnaires and the other on observation. Although these approaches are different from those used in the laboratory, they share common goals—development of standardized techniques of measurement and progressive refinement of measurement procedures.

Let us illustrate one procedure. This is the survey questionnaire approach used to better define the problem.

Since we cannot readily define the problem, we cannot ask specific questions about it. Instead, questions are asked in a way which permits the people being questioned (**respondents**) to “volunteer” information—i.e., provide information in a natural way, using their own words. Furthermore, we must be sure to ask the questions in a way that does not provide biased results.

A questionnaire would be administered during daytime and evening hours to all who use the school building. The questions could be as follows:

What do you think about the room as a place to perform your activity?

Are there advantages or disadvantages of this room as compared with rooms specifically designed to perform this activity?

If there are, could you tell me what they are?

A compilation of responses to such questions often leads to some reasonable guesses as to the major variables which can then be explored in more detail in follow-on surveys.

For example, if many respondents said they were disturbed by other activities, later versions of the questionnaire might address this problem more directly. Questions would be asked about the activity being disturbed, the cause of the disturbance, the nature of the disturbance—e.g., difficulty paying attention to the teacher. Survey research is not simple; it calls for skills comparable to those needed for other M/E study areas. (Chap. 20 includes a detailed discussion of this topic.)



*Open Space Design in School (AIA Journal)*



## Multivariate and Parametric Compared

Those who do M/E research may be divided into those who advocate traditional research methodology (single variables, parametric) and those who deplore this approach because the subject matter is so complex.

Social scientists have been at the forefront of those who favor multivariate research. They claim that the number and complexity of the variables (parameters) and their interactions—whether dealing with people, institutions, social programs, or environmental issues—do not permit us to examine things one at a time, i.e., parametrically. The world is complex, and must be understood on those terms. Once we try to simplify our observations by employing inherently artificial simulation procedures (controlled research), we change the situation (person, environment) in an important way, and any findings obtained may be misleading.

For example, if high temperature is a disturbing factor in a classroom situation, field researchers argue that it must be studied in the context of that situation—not brought to a laboratory for an in-depth study. Temperature levels should be considered as one environmental factor which, together with lighting, noise and social factors, operate in terms of the particular activities in the classroom, e.g., a multivariate approach.

On the other hand many parametric researchers are skeptical of multidimensional procedures. They point to the many factors in a situation which researchers may not understand or take into account. The lack of understanding of important M/E variables places the researcher in a position similar to that of the architect, where every design problem tends to be treated as unique. This is a key obstacle to an effective M/E discipline, now bogged down because the findings of studies can seldom be generalized. As a result, researchers attack similar problems again and again, resulting in enormous waste of time and resources, and little improvement in the overall quality of information available to designers.

Advocates of parametric research share the belief of traditional disciplines that natural phenomena are essentially *simple* and understandable, and therefore a systematic, single variable approach is an appropriate one. They argue that once basic M/E variables are defined, one can make statements about relationships that hold true for *all* buildings, not only those being studied. For example, all people share a biological inheritance which enables them to perceive the world as they do. As more is learned about the way the eye responds to light and dark situations, we are better able to predict with confidence what lighting is necessary when people must move from a light to a dark situation (entering a theatre). This lighting problem arises in many building types—but the solution is universal because of the way people see.

## Criteria for Evaluating Research

Research may be performed well or poorly. From the standpoint of a scientist, the willingness to accept data as being a true measurement of a phenomenon depends on two overall criteria—**validity** and **reliability**.

The validity of a measurement is concerned with whether the property *being* measured is what should be measured—i.e., are we measuring the right thing? For example, before the advent of jet aircraft, noise measurements were generally made by obtaining a dBA reading on a sound level meter. (The “A” scale was designed to approximate the sensitivity of the ear to sound by means of a weighting network.) The dBA scale was found to be inadequate when judging jet aircraft noise, because it did not account for one of its most disturbing characteristics—a high-pitched pure tone annoying to listeners. The dBA scale was therefore found not to be *valid* for assessing annoyance due to aircraft noise. (For detailed discussion of noise see chap. 10.)

Here now is a number of specific approaches used to assess the validity and reliability of research.

## Validity—Thermometers Do Not Measure Light

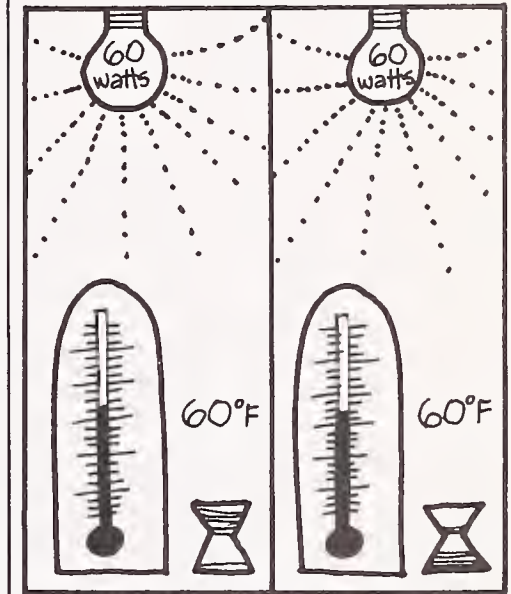

Even if a test method is reliable, it is not necessarily **valid**.

A research investigation is rarely the first to be performed in a subject area. Consequently, most findings can be tested to determine whether they are plausible (consistent with earlier data). If the research findings of a given study are unprecedented, it does not mean that they should not be believed. Instead, the experimental procedures and analysis of data warrant closer study to ensure that errors did not account for them. In any event, the researcher can expect others to scrutinize such findings, and it would be therefore prudent to make this check.

K. Craik (psychologist) looked at the correlation between the actual environment and photographic representations of it. He compared ratings made on the attractiveness of natural landscapes with photographs of the same landscapes. Two surveys rated the natural landscape at 92 locations. Later, nine judges rated the same landscape on the basis of photographs taken at each of the 92 locations. Craik found a high correlation (+0.64) indicating that photographs seemed a good means for simulating the natural landscape.

Using another technique, experimenters hoped to validate questionnaires as a means of determining television viewing behavior. In the study R. Bechtel (psychologist) et al. placed cameras in homes to monitor television viewing behavior.

Two cameras were set up to switch on when the family television set was turned on. One camera was positioned over the television set and gave a wide angle view of the room and the viewers. The second camera was directed at the set and recorded the programs being watched. Three microphones were positioned in the room. The recording was monitored by an equipment operator in a rented truck parked either in the driveway or behind the house. Tapes were coded for each viewer every 2 1/2 minutes for 6 categories of involvement in television viewing and 11 categories of program type.

As expected there were obstacles in getting people to agree to have cameras placed in their homes. As an inducement, \$75 for 6 days' participation was offered to the families. Three questionnaires (including one in diary form) were completed by those families whose viewing behavior was monitored. The questionnaires allowed a comparison of subjects' reports of programs viewed and attention paid to them with actual behavior. The results showed subjects often exaggerated their television viewing time on the questionnaires and diary when compared with viewing time as recorded by the cameras.

We have discussed several factors used to evaluate the "validity" of research. We will now touch upon the subject of "reliability."

Reliability refers to whether other researchers performing similar studies obtain equivalent results. This emphasis on reliability (repeatability) is inherent in the research process, which depends on observations and measurements, development of a predictive model to explain a phenomenon and then finally (and most importantly) the collection of empirical data to verify the prediction. This process cannot take place in the presence of events which occur only once. As a consequence, the assumption is made that there is no such thing as a unique event. For example, the biblical flood has been explained in terms of a series of natural events, each one unlikely, and in combination even more so.

## Categories of Involvement in Television Viewing (Bechtel)

Code	Behavior
<b>Attending screen</b>	
1	Participating, actively responding to the TV set or to others regarding content from the set
2	Passively watching (doing nothing else)
3	Simultaneous activity (eating, knitting, etc.) while looking at the screen
<b>Not attending screen</b>	
4	Positioned to watch TV but reading, talking or attending to something other than television
5	In the viewing area of the TV but positioned away from the set in a way that would require turning to see it
6	Not in the room and unable to see the set or degree of impact of TV content

## Reliability - Light Measurement Study

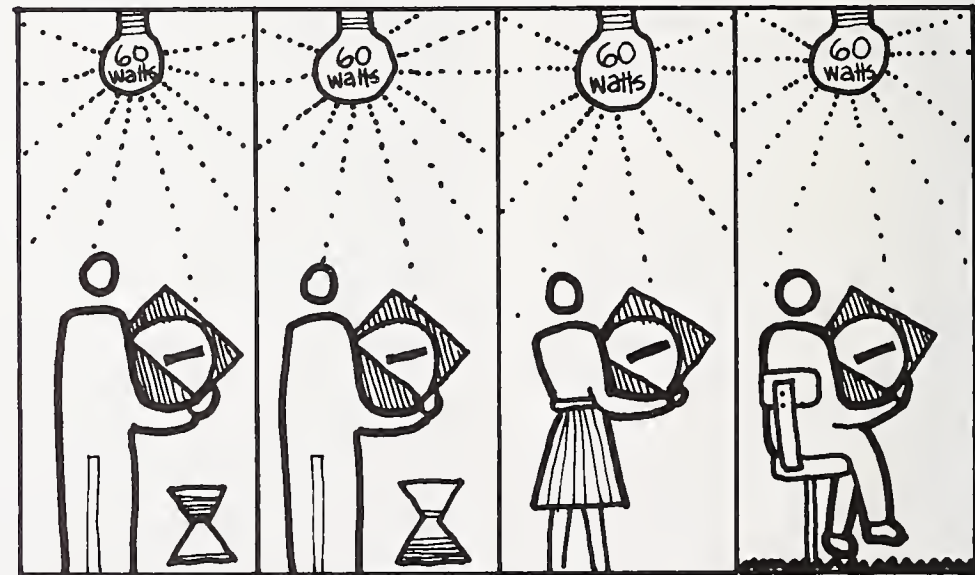

Test method is **reliable** if a change in other variables (time, researcher, environment, etc.) does not effect the test result.



## Objectivity and Research

Before continuing our discussion, let us again examine the observations typically made in M/E studies.

Some observations (and measurements) are straightforward and readily obtained, while others require the researcher to make inferences about what is being observed. The key to performing research based on objective data is to ask questions in a form which minimizes the need for making inferences. For example, we may want to determine how many people use a particular entrance to a building. This could be done by counting the people entering a doorway, requiring no particular research skill.

Now, assume that people had to open a door in high wind to enter the building. We want to determine whether people "had difficulty" using that door under these circumstances. In the latter case, we would have to define the term "having difficulty" in a manner which enables us to make meaningful observations of the activity. The behaviors observed might be to determine whether:

- Two hands were required to open the door.
- Opening the door took more time than during other weather conditions.

The researcher then uses observations of these (or other) behaviors to determine whether people "had difficulty" while opening the door. An *inference* must be made by the researcher because the problem being explored was not defined in a way that was self-evident and directly observable—as previously where people were counted. When such inferences are necessary, it is frequently difficult to get other researchers to agree that the behavior being observed is an appropriate measure of the activity being examined. For example, individual strength when opening a door is an important determinant of the observed behavior, yet it is not readily measured without proper apparatus. Similarly, motivation to open the door quickly to flee the wind would lead many people to exert themselves more than usual, introducing errors into the time measurements. Both attributes are not readily observable and could therefore lead to biased results.

Consider another example where inferences play an important role.

Questionnaires are often developed to obtain information concerning the responses of people to their environment. An example of this technique is to ask experimental subjects: *Do you prefer incandescent or fluorescent lighting for reading, if the levels of illumination are equal?*

People respond by *saying* what they prefer *if* faced with such a situation. The trouble is that people frequently do not *act* as they say they would and therefore the results of survey findings must be tested to relate what people *say* to what they *do*.

A more objective approach to the same problem would be to design two spaces for reading having the characteristics noted, and then make observations of how many people actually use each space and for how long. In the latter instance we are not asking subjects to *predict how they would behave*—observations are made directly. Moreover, these observations can be recorded by closed circuit television and by motion pictures, and hence be verified by other investigators.

Unfortunately, many subject areas of M/E studies are even more complex than these requiring a chain of inferences before specifying what observations should be made, e.g., territoriality, privacy, security, comfort. Thus there are almost as many definitions of these concepts as there are researchers.

To eliminate inferences in research, the concept of an **operational definition** was developed. P. Bridgman (physicist) described it as follows:

*We may illustrate by considering the concept of length: what do we mean by the length of an object? We evidently know what we mean by length if we can tell what the length of any and every object is, and for the physicist nothing more is required. To find the length of an object, we have to perform certain physical operations. The concept of length is therefore fixed when the operations by which length is measured are fixed: that is, the concept of length involves as much as and nothing more than the set of operations by which length is determined. In general, we mean by any concept nothing more than a set of operations; the concept is synonymous with the corresponding set of operations.<sup>3</sup>*

<sup>3</sup> P. W. Bridgman, *The Logic of Modern Physics* (New York, 1960).



In M/E studies the development of operational definitions for phenomena might be especially worthwhile. Phenomena are open to many definitions, thereby leading to confusion among architects as well as researchers. The ambiguity poses special problems for the researcher who wants to make observations and measurements. What does he look for? How can quantitative findings be produced?

When operational definitions are to be used, we are compelled to identify what is to be observed and how to make measurements. This exercise might lead to restrictive (incomplete) definitions at first, but these can later be expanded to include other aspects of the phenomena after we have identified them sufficiently.

Let us consider the concept of privacy. One aspect of privacy is the ability to speak without being overheard by others. It is possible to determine the extent to which conversations in one space are understood in other spaces. Visual privacy can be examined the same way by determining what can be seen from a variety of vantage points surrounding a space.

Two aspects of privacy can then be observed and measured. As we identify other components of privacy, they can be examined in the same manner—if they are capable of being defined in terms of observable operations. If not, they may not be capable of being researched at all.



*Visual Privacy in Open Space Design (NBS)*



*Difficult to Evaluate "Real World" Noises (NBS)*

## Research Controls

It is one thing to point out the need for collecting objective data, but it is quite another to accomplish this goal in M/E research. One primary focus is the behavior of people, which is at best determined only partially by environmental characteristics. For example, experience and motivation are known to influence many kinds of behavior; yet we often have no means of measuring them objectively. In animal studies experience has been defined as the number of "trials," while motivation is frequently defined as the time elapsed since the most recent feeding. While these approaches have sometimes been used in studies of human subjects, their use has been limited for ethical and research reasons.

The standardization of procedures to observe and measure is important in all research. This emphasis does not eliminate errors. Instead, errors introduced into research are dealt with by statistical and other procedures. As an illustration, the dBA scale has been used to measure noise. The levels obtained were employed to assess the effects of noise sources on building occupants. Yet, dBA measurements do not adequately account for other characteristics of noise known to affect listeners, e.g., pure tone components, impulsive sounds. The dBA scale should therefore be used cautiously when noises have important impulsive and pure tone characteristics.



Observations and measurements cannot be error free. Errors are therefore inherent in the research process. The researcher's goal is not to eliminate errors, but to reduce them to a level consistent with the demands of a particular study.

The standardized procedures for making observations and measurements (collecting data) are designed to reduce the type and magnitude of errors in an experiment. The procedures differ according to the study. Let us examine several typical approaches.

E. Wilson (chemist) notes that: *The ideal experiment is sometimes described as one in which all relevant variables are held constant except the one under study, the effects of which are then observed.*<sup>4</sup>

In M/E research, studies dealing with environmental characteristics such as temperature, light, and sound levels are frequently performed under controlled conditions, approaching those described by Wilson.

For example, if we wanted to examine the effect of sound intensity on the acceptability of the environment, we would ensure that other characteristics of sound would be the same for all experimental conditions. Such an experiment might consist of having people listen to a series of sounds of fixed duration (30

seconds), made up of identical frequency components (between 50-1000 Hz), and which are varied in accordance with their intensity (40 dB, 50 dB, 60 dB, 70 dB, 80 dB). The *independent* variable would be the different sound levels while the duration and frequency of the sounds would be *control* variables, and judgments of acceptability would be the *dependent* variables. Since many other extraneous factors—environmental and personal—might also affect judgments, these would be controlled to the extent possible, not only in laboratory studies but in field investigations as well.

### Typical Laboratory Research Controls

- Selection of the subjects—e.g., age group
- Instructions for responding (dependent variable)
- Characteristics of the sound (independent variable)
- Levels of sound (independent variable)
- Freedom from extraneous stimulation—auditory, visual (laboratory environment)
- When and where observations are made
- Number of observations made (at discretion of researcher)
- Form of data

The questionnaire survey enables the researcher to maintain considerable control over observations. Control is exercised in several ways. First, the *questionnaire items* (questions) are standardized. All experimental subjects are asked the same questions, in the same sequence. Furthermore, control may be obtained by designing the questions in a way which limits acceptable answers; for example, requiring subjects to answer (1) I agree, (2) I disagree to a series of statements. Finally, we can require subjects to answer all questions, even difficult ones (by guessing if necessary).

Another control is to train the people who administer the surveys, to ensure consistency. Thus, we may ask that instructions be read by (or to) subjects and that no additional information be provided. If someone wants a question clarified, the instructions may be read again. Other controls can include: the uniformity of the background and education of those who administer the survey and the way (e.g., tone of voice) that the questions are asked. (A more detailed treatment of this subject appears in chap. 20.)

The survey questionnaire approach requires respondents to take an active role in an investigation. Normal activities are thereby disrupted in order for them to participate. Many M/E researchers prefer observations of activities to be made in their natural settings. Consider, for example, the requirements of elderly residents of a nursing home.

One characteristic noted in studies of the elderly is their desire to control access to their space—a need for a defined territory.

If we wanted to examine these activities in a realistic setting, we should define the types of observations needed to determine territorial and visual access needs. Researchers, serving as expert observers, could then be trained to look for (and record) the same events. For instance, a group of people might be observed to see if any behaviors are attributable to the presence or approach of a stranger, e.g., moving closer together, starting conversations. Further control is sometimes possible by developing checklists or other forms to collect data—reminding observers what to look for.

### Conclusion

In the present chapter, we have discussed several factors associated with performing research. We described the use of experimental approaches to collect information. Ultimately, however, the development of a scientific discipline requires not only orderly means of making observations, but the ability to make quantitative statements about them. In research two types of quantitative approaches are used, one related to measurement per se, and the other related to statistical and sampling concerns. Both of these issues will be discussed in the following chapter.

<sup>4</sup> E. B. Wilson, *An Introduction to Scientific Research* (New York, 1952).



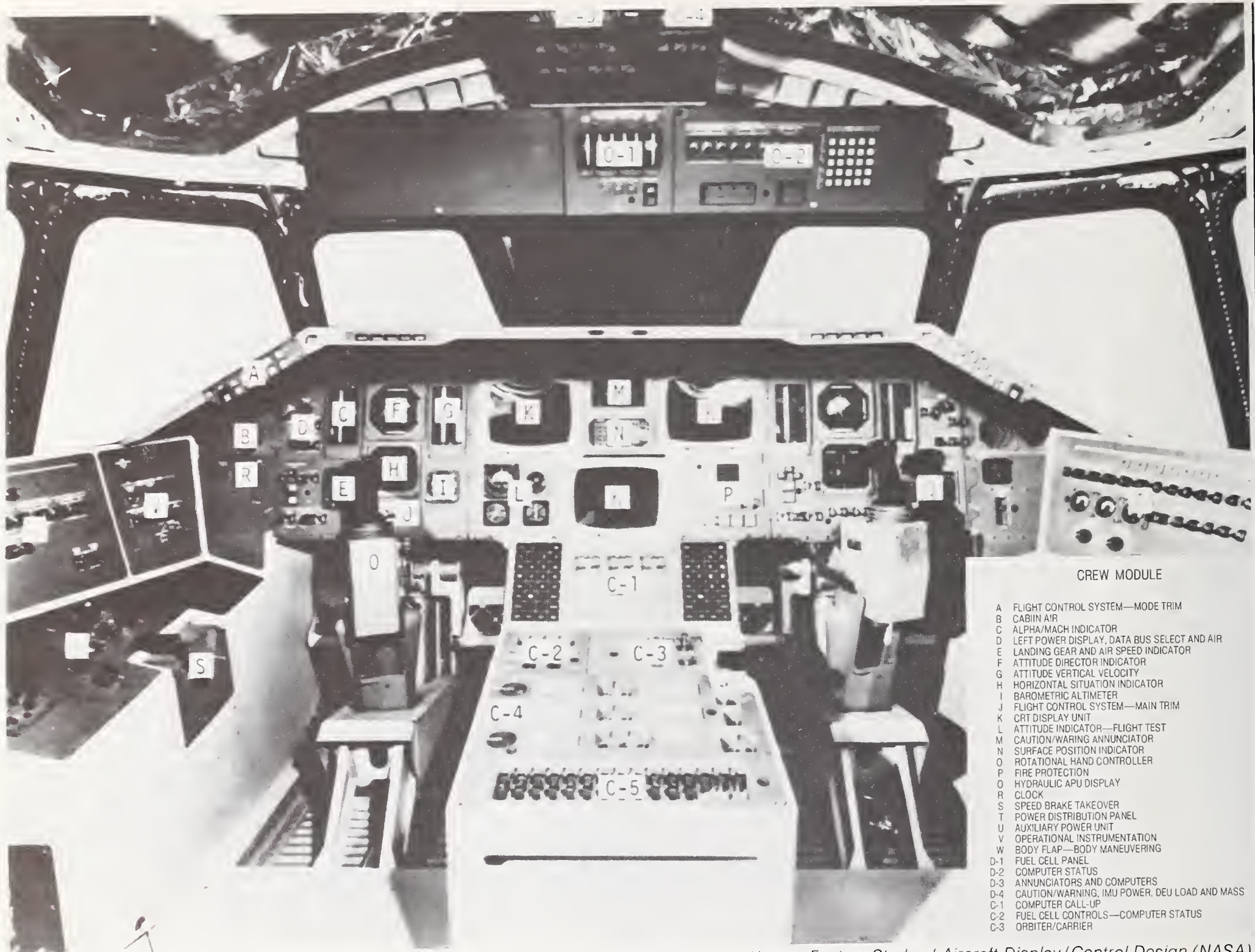

CREW MODULE

- A FLIGHT CONTROL SYSTEM—MODE TRIM
- B CABIN AIR
- C ALPHA/MACH INDICATOR
- D LEFT POWER DISPLAY, DATA BUS SELECT AND AIR
- E LANDING GEAR AND AIR SPEED INDICATOR
- F ATTITUDE DIRECTOR INDICATOR
- G ATTITUDE VERTICAL VELOCITY
- H HORIZONTAL SITUATION INDICATOR
- I BAROMETRIC ALTIMETER
- J FLIGHT CONTROL SYSTEM—MAIN TRIM
- K CRT DISPLAY UNIT
- L ATTITUDE INDICATOR—FLIGHT TEST
- M CAUTION/WARNING ANNUNCIATOR
- N SURFACE POSITION INDICATOR
- O ROTATIONAL HAND CONTROLLER
- P FIRE PROTECTION
- R CLOCK
- S SPEED BRAKE TAKEOVER
- T POWER DISTRIBUTION PANEL
- U AUXILIARY POWER UNIT
- V OPERATIONAL INSTRUMENTATION
- W BODY FLAP—BODY MANEUVERING
- D-1 FUEL CELL PANEL
- D-2 COMPUTER STATUS
- D-3 ANNUNCIATORS AND COMPUTERS
- D-4 CAUTION/WARNING, IMU POWER, DEU LOAD AND MASS
- C-1 COMPUTER CALL-UP
- C-2 FUEL CELL CONTROLS—COMPUTER STATUS
- C-3 ORBITER/CARRIER

Human Factors Study of Aircraft Display/Control Design (NASA)



# 5

## Man/Environment Research

### Improved M/E Information

#### Theoretical Issues

- Parametric Models
- The Stimulus (Environment)
- Correlational Model
- Other M/E Models

#### Observational Approaches

#### Simulation Approaches

- Scale Models
- Photographs
- Games

#### Other Data Collection Methods

- Semantic Differential
- Adjective Checklist
- Diary
- Unobtrusive Measures

#### Conclusion

*Very few architects stand any real chance of becoming successful free-lance practitioners. . . it means that the employed architect in the big office will become increasingly specialized, seeing less and less of the entire field of practice and of the clients themselves. Second, it implies that more and more of his clients are themselves corporate entities—big business, big institutions, big government.*

*The implications here are disturbing, in that the architect's legal client is less and less his real client. The white collar worker in the big skyscraper, the blue collar worker in the big plant, the housewife in the big housing project, the child in the big consolidated school—these are the people for whom the architect works and to whom he is ultimately responsible. His buildings should be accurately and sensitively designed for them. Yet these are the people whom the architect today seldom sees. He deals instead with their agents—those corporate or institutional entities who are the legal owners of the projects.*

*It cannot be assumed that these corporate or institutional clients, acting though they may be as legal agents for the consuming public, are always to be relied upon to represent its best interests or optimal requirements. In a profit-motivated society, criteria for architectural projects are all too apt to approach the minimal permitted by building codes or the law of supply and demand. Of course, this tendency will vary from field to field.*

*The building consumer is unable effectively to express his demands, requirements, expectations; and the architect's isolation from them leads inevitably to the abstract, the formal and the platitudinous in architectural and urban design. It is also expressed in changes in his cultural orientation. By the very nature of his work, the architect has always stood closer to the rich than to the common man, for whom his services were always less imperatively required than those of the doctor or lawyer. Nevertheless, the tradition of the socially conscious, intellectually committed architect has had a long history in the United States. The social client gave the architect an exhilarating sense of identity with society. It served to shift his attention, if not his allegiance, toward social architecture.<sup>1</sup>*

<sup>1</sup> J. M. Fitch, *The Architectural Manipulation of Space, Time, and Gravity* (New York, 1969).

The architect should have information on M/E issues comparable in quality with that required for making decisions about the structural integrity of a building. In both instances, erroneous information can lead to building failures. When making engineering decisions, the architect can draw upon a broad base of information carefully collected and tested by standardized procedures which can be traced to scientific studies. No comparable foundation exists in the M/E realm.

Instead, M/E information is very uneven with respect to quality and accessibility. Studies have often been performed to answer quite specific problems, and consequently have little general applicability. Furthermore, in too many instances, the information developed in M/E studies is difficult to evaluate because the research procedures and controls used have not been adequately documented. Since these very procedures distinguish scientific research from casual observation, the questionable quality of much M/E data is not surprising.

If we can assume general agreement exists among architects and concerned researchers for the need for better information, how should we proceed to get it?

Two of the most important such needs are: (1) a well-defined subject area of study, and (2) standardized procedures (methodologies) for making observations and measurements. In short, a scientific discipline needs to be established.

The most striking feature about M/E research is the breadth of interest. It would be difficult to find another discipline with a comparable range of interest. Relevant information includes characteristics of people (physiological, psychological, cultural, social), attributes of the natural and built environments, and, most importantly, interactions of people and their surroundings. These form the basis for defining the requirements of building users.

Many disciplines can contribute toward a better understanding of M/E relationships. The design problem being investigated will dictate the proper approach. The one major attribute that the disciplines *share* is the employment of scientific methods in collecting data.

Anyone familiar with one or more of the M/E disciplines knows that a comprehensive treatment of measurement procedures for any one discipline would be a vast undertaking. Instead, in Parts III, IV, and V of the report, measurement methods have been selected from many disciplines to point out the diversity of approaches available.

This chapter presents an overview of the general approaches employed in M/E research studies, and a short discussion of the theoretical bases for them.

## Improved M/E Information

An architect employs engineering and other design data to ensure the adequacy of a building from the standpoint of safety and health. The availability of such data may be traced to the ability of researchers to identify and measure the important parameters of materials, built elements, building subsystems and the like and relate them to the performance of a building.

The quality of scientific information depends on the consistency and relevance of the observations made by researchers in the same study

area. Researchers who employ standard methods, observing similar phenomena, will obtain equivalent data. "Hard" sciences can be differentiated from "soft" sciences in terms of their ability to obtain such reproducible findings. Moreover, hard sciences, because of the objectivity inherent in most observations, can make quantitative statements about their observations, i.e., they use sophisticated measurement techniques. Measurements, in turn, enable scientists to employ mathematical techniques to develop conceptual models of the phenomena. These models are an integral part of the research process of formulating hypotheses, which are then tested by collecting experimental data.

## Development of Improved User Information

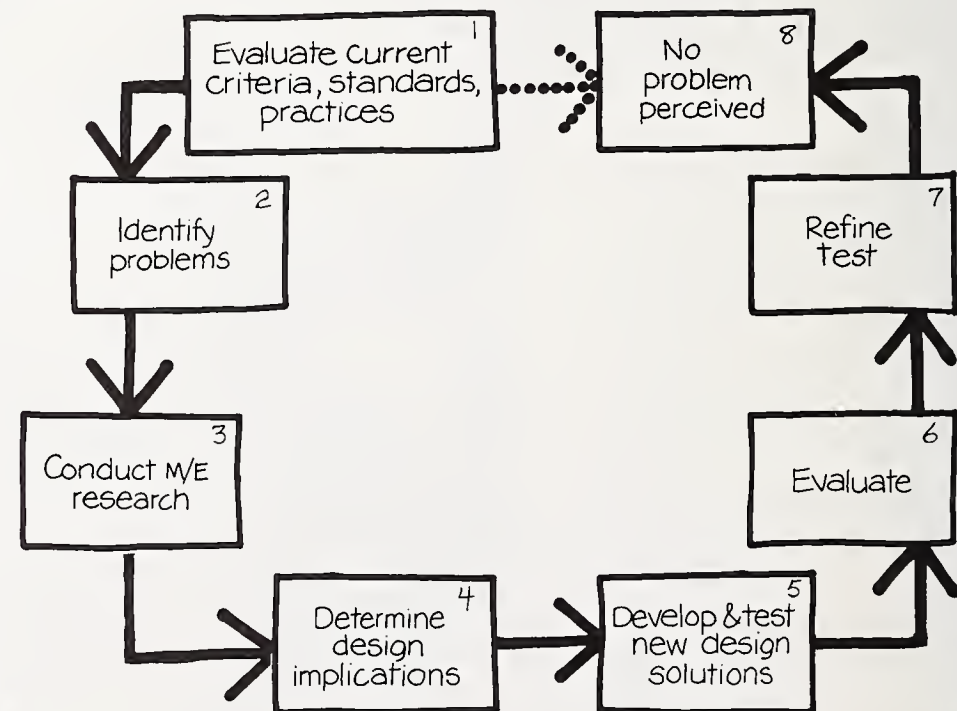



## Theoretical Issues

We will not develop or advocate someone else's conceptual scheme (model) to explain how people interact with the built environment. On the other hand, researchers do not conduct their studies in a theoretical vacuum. Even researchers who conduct studies for the most pragmatic purposes (solving a particular design problem) make assumptions about the likely effect of design features on the way people act. These assumptions, when taken together, constitute a conceptual (theoretical) model.

## Parametric Models

The search for objectivity in behavioral studies has led some researchers to develop S-R models, which eliminate the need to be concerned about differences among people. Behavior (Response-R) is explained solely in terms of environmental (Stimulus-S) conditions. This model if successful would have been ideal for the architect because it infers that the behavior of people could be *determined* by the nature of their surroundings. (If the architect wants people to act in a particular way, all that he has to do is design a building appropriately.) The S-R model has proven to be far too simplistic to deal with the behavior of people because it fails to account for the characteristics which make people different from one another. Furthermore, it implies that behavior is deterministic, i.e., that individuals have no control over their destinies.

A classical behavioral research model which accounts for differences among individuals is termed the *Stimulus (S), Organism (O) and Response (R) (S-O-R)* approach. Briefly, the behavior of organisms (people and animals) is explained in terms of characteristics of the outside world and attributes of the individuals who interact with the outside world. Behavior (R) is explained in terms of an environmental feature (S) which affects a person (O) in a particular way. Although the model was developed to explore individual behavior, it readily lends itself to categorizing many of the variables in M/E studies.

The S-R and S-O-R models of behavior are basically analytic in that the research goal is to determine cause/effect relationships between independent (S) and dependent (R) variables, while controlling differences among individuals (O) by means of the design of the experiment.

## The Stimulus (Environment)

S. Stevens (psychophysicist) examined the M/E problem in another way. He indicated that, in a sense, only one problem must be solved in psychology—defining the stimulus.

His reasons are expressed as follows:

*The complete definition of the stimulus to a given response involves the specification of all the transformations of*

*the environment, both internal and external, that leave the response invariant. This specification of the condition of invariance would entail, of course, a complete understanding of the factors that produce and alter responses. It is easy enough, of course, to decide upon arbitrary definitions of "stimulus objects" (e.g., a given pattern of lines, a quantity of luminous flux, an acoustic waveform, etc.), but the question is: what properties of these objects do the stimulating? Viewed in this fashion, it is evident that for no response have we yet given a complete definition of the stimulus. At best we have only partially determined the conditions and limits of invariance.<sup>2</sup>*

He illustrates this point by examining a well-researched area—hearing. Under what conditions do people perceive a particular pitch? Can the frequency of a sound be changed without any change in pitch perception? (Yes, within limits.) Can the phase be changed with similar results? (Yes, also within limits.) He then goes on to state that the effects on pitch perception of many other parameters having potential importance are simply not known, e.g., waveform, power spectrum, duration. We therefore know very little about the "stimulus" which produces pitch sensations. Moreover, when we examine complex responses such as attitudes and preferences or a sense of privacy and territoriality, even less is known about the conditions which produce these responses.

<sup>2</sup> S. S. Stevens, *Psychophysics* (New York, 1975).

Stevens then notes that in one way or another, we are constantly guessing the physical values or relations of stimuli. That is, we have a subjective impression which is used to predict the result expected if an objective measurement were made. For example, we may try to judge the size of objects within a room or the length of a corridor, then actually measure them.

Stevens correctly states that if we had sufficient information about the environment (S) and its relationships to the person, then the work of psychologists (and M/E researchers generally) would be completed. Unfortunately, the "if" is prodigious.

## Correlational Model

Many M/E researchers have concluded the complex problems which concern them cannot be solved using the traditional analytic approach. Instead, an alternative one has been advanced—namely to find the degree of relationship between the variables being examined—without making cause/effects statements.

For example, we might want to see if students prefer any location in a library. More specifically—are the tables near the windows used more than the others? (We would be testing the hypothesis that library design should maximize window area.)

By observing existing library usage, we can determine the relationship between proximity to windows and usage. If we assume that usage and nearness to windows are highly correlated (the closer to the window, the more likely the table was to be occupied), we might conclude that library seating arrangements should take this factor into account. This recommendation might be plausible even though we had no idea as to *why* people were seated as they were. The reason might be due to one or more window characteristics but other ex-

planations are possible—territoriality, privacy, lighting levels, or other factors. Explaining *why* these results occurred may or may not be important, depending on the reason for conducting the study. For the designer the fact that it *did* occur (assuming that the study was well conducted) is sufficient. The researcher will want a more complete explanation however.

The correlational model therefore stresses applications of findings, while parametric (e.g., S-O-R) models are directed toward a more fundamental understanding of

relationships between environmental and behavioral factors.

R. Barker (psychologist) developed a theoretical model which provides a valuable framework for considering M/E problems. His concern is with the psychological environment (the world as it is perceived by a person) and with the ecological environment (the real life setting within which people behave). He has been the major proponent of **ecological psychology** which emphasizes the need to study human behavior in a realistic setting with all of its complexities. By describing the environment in which behavior takes place, Barker hopes to better understand the relationship between a specific environment or setting and the behavior occurring in it.

In defining the subject matter of ecological psychology, he indicates that it is necessary to *identify the natural units of the phenomenon studied. The essential nature of the units with which ecology deals is the same whether they are physical, social, biological, or behavior units: (a) they occur without feedback from the investigator, they are self generated; (b) each unit has a time-space locus; (c) an unbroken boundary separates an internal pattern from a differing external pattern.*<sup>3</sup> Examples of such units are towns, schools, class meetings, baseball games. The author uses the term **behavior setting** to describe these units.

*Behavior settings have provided a basis for describing and measuring the extent, the variety and the behavior output of the environment and of relations between its extent and its output. In this,*

*behavior settings have entered as entities with a variety of properties that can be directly observed and measured.*<sup>4</sup>

## Behavior Setting Attributes (Barker)

### Attribute/Example

1. **Geographical locus**  
(Location in space)
2. **Occurrence**  
(Number of days a year)
3. **Duration**  
(Number of hours a year)
4. **Population**  
(Total number of different persons involved in a year)
5. **Functional position of inhabitants**  
(Level of involvement by participants)
6. **Action patterns**  
(Arbitrary; such as, aesthetic, governmental, education, social, religious, etc.)
7. **Behavior mechanisms**  
(Affective, gross motor, manipulation, verbal thinking)
8. **Pressure**  
(Degree to which population sub-groups encouraged to enter and participate)
9. **Autonomy**  
(Degree to which behavior setting subject to external influence)
10. **Welfare**  
(Degree to which needs of various groups met)

## Proximity to Windows → Increased Use

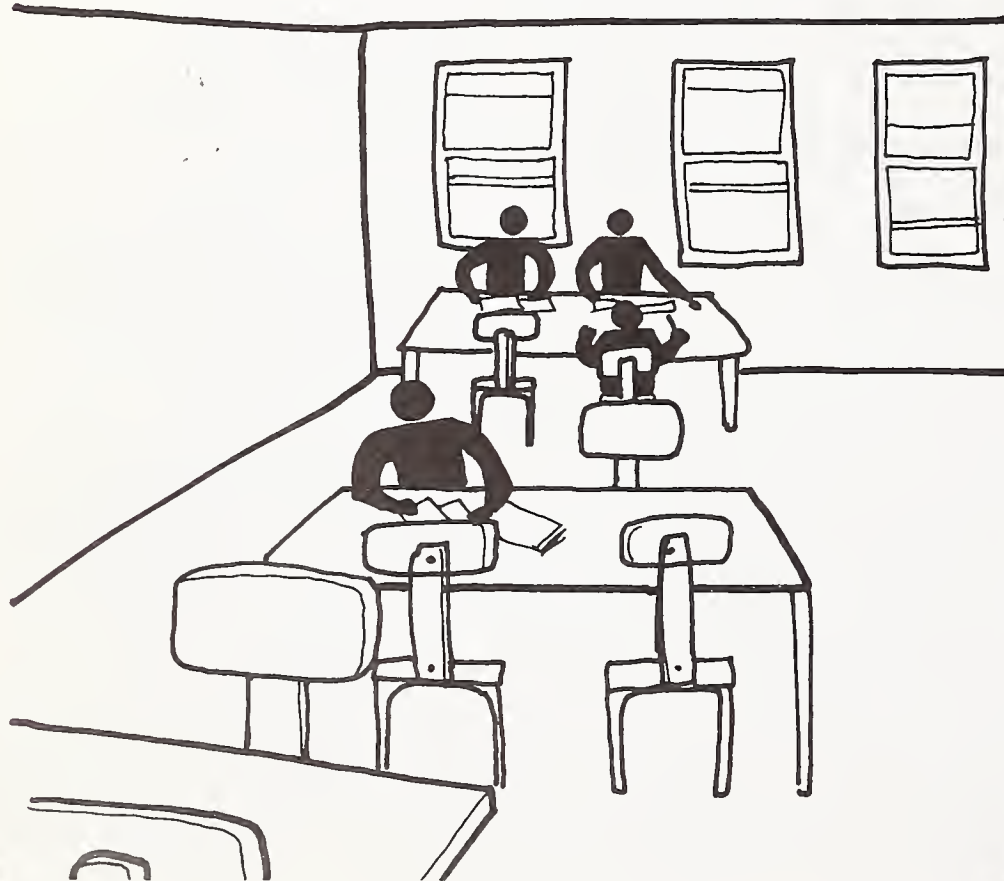

<sup>3</sup> R. G. Barker, *Ecological Psychology: Concepts and Methods for Studying the Environment of Human Behavior* (Stanford, 1968).

<sup>4</sup> Barker



Barker conducted a field study to validate and further explore his theoretical concepts. The researchers documented behavior settings and their characteristics for an agricultural town in Kansas. The town had a population of about 11,000 and was studied for one year. Ten attributes were defined and used to describe each behavior setting. From these descriptions the researchers were able to: (1) identify and describe the behavior settings in the town, (2) categorize the behavior settings into major groups so that settings with similar characteristics could be studied as one major setting and, (3) describe the behavior settings on the basis of the activities (or behaviors) which occurred within them. For example, High School Latin Class was identified as a behavior setting. There were two Latin Classes during the year, with a total duration of 341 hours. Latin Class falls under the more comprehensive category of school and is part of the action pattern of education. Thinking represents the major action pattern and "attendance encouraged" describes the pressure profile. The welfare of adolescents is benefitted. Finally, the activities which take place in the Latin Class behavior setting (thinking, etc.) were compared with the activities taking place in other behavior settings.

Barker originally carried out his work for the purpose of developing a theory. D. Aas (Norwegian researcher) looks beyond the theory and discusses the practical applications of Barker's work. *The insight provided by the theory makes it possible to better grasp the meaning of activity. The theory stresses that the environment is part of the activities and that activity is a vital part of the environment. Furthermore, stress is put on the dimension of time: behavior and activity are segments of time and can be seen as sequences and strings of related actions.*<sup>5</sup>

### Action Patterns (Barker)

#### Aesthetic

##### Attribute

Artistic activity of behavior directed toward beautification

##### Participation

Doing artistic work of any kind (scaled from 0-5)

##### Supply

Providing materials and equipment which are directed toward aesthetic enjoyment—musical, artistic material (scaled from 0-5)

##### Evaluation and Appreciation

Assessing the products of art or the ability of artists

##### Learning

Formal teaching or learning of an aesthetic activity

Aas reports on a behavior setting study in a Norwegian town which looked at social-cultural activities and ultimately attempted to identify the types of facilities needed for these activities. Initially a behavior-setting survey was carried out to determine the range of activities that should be included in the study. Simultaneously, an interview study of people's leisure-time activities was conducted. Eight hundred organizations were identified as supporting, arranging, and directing the activities of interest. Daily, detailed information on the events

#### Business

Exchange of goods, services or privileges for money

Transporting or exchanging goods for a fee

Supplying objects or material necessary for business purposes

Appreciation of achievements or values of other businesses

Instruction in the conduct of business transactions

sponsored was obtained from 400-500 such organizations. From these data it was possible to determine: (1) The number of organizations sponsoring activities; (2) The number of general types of activities throughout the year; (3) The total number of events taking place; and (4) The average duration of the events.

Aas then calculated the average time per person spent on sociocultural activities. With all of this information it was possible to draw several conclusions concerning the activity studied. Recommendations could be made on the adequacy of existing facilities, on the scheduling of events and on the population's interest in these events. In Barker's terms, Aas looked at the occurrence, duration, population, and occupancy time associated with a behavior setting (sociocultural event) within a particular milieu (the Norwegian town studied).

<sup>5</sup> D. Aas, "Observing Environmental Behavior: The Behavior Setting," in *Behavioral Research Methods in Environmental Design*, ed. W. Michelson (Stroudsburg, 1975).

## Other M/E Models

Another set of models is applicable to M/E research. These are defined in terms of their function:

*Descriptive models.* The prime function of these is to portray the relationships that are seen to exist in a situation. For instance models of circulation movement showing the relationship of corridor and lift dimensions to flow capacities, structural equations showing the relationship of shape and dimension of members to stress and deflection. Most research findings produce descriptive models of this kind.

*Predictive models.* Given a set of relationships (descriptive models), if one variable can be predicted and the relationship holds, then the other variable(s) can be predicted. For instance for a given size and speed of lift the waiting time (under a specified arrival pattern) can be predicted. For a given shape of building the air-conditioning load can be predicted.

*Decision models.* From a set of predictive models (alternative solutions) one must be chosen. This requires the use of a criterion. When this is done analytically, to derive an optimum, by such tendencies as linear programming for instance, the optimisation procedure involves building this decision model.<sup>6</sup>

With this brief treatment of conceptual models and their relationship to the development of needed M/E information, we will return to our major concern of making observations and measurements of building users.

## Observational Approaches

What do we mean by **observations** in M/E studies? The word covers characteristics and measurements of the environment, activities and the individual, whether recorded by an experimenter, a subject or by instruments. "Observation" is used in the broadest sense—whatever is being examined in any form.

M/E observations include environmental attributes as well as responses of people. The environment under study must be meaningfully described and/or measured, if we are to make progress in determining its effects on the behavior of building occupants. However, since this work is written by psychologists, not physical scientists or engineers, its emphasis is on people. We assume that members of the design team with these skills will make the needed observations. Since our main concern is the *person*, we feel that physical scientists should not be the only ones to decide which physical attributes of the environment are to be observed and measured. That has often happened, e.g., in noise research, acoustic measurements are often made because the state-of-the-art makes such measurements possible and not because people respond to the attributes being measured.

<sup>6</sup> T. A. Markus, "The Role of Building Performance Measurement and Appraisal in Design Method," *The Architects' Journal Information Library* (December 1967).

## The Fidelity and Flexibility of Varying Test Techniques (VanCott)

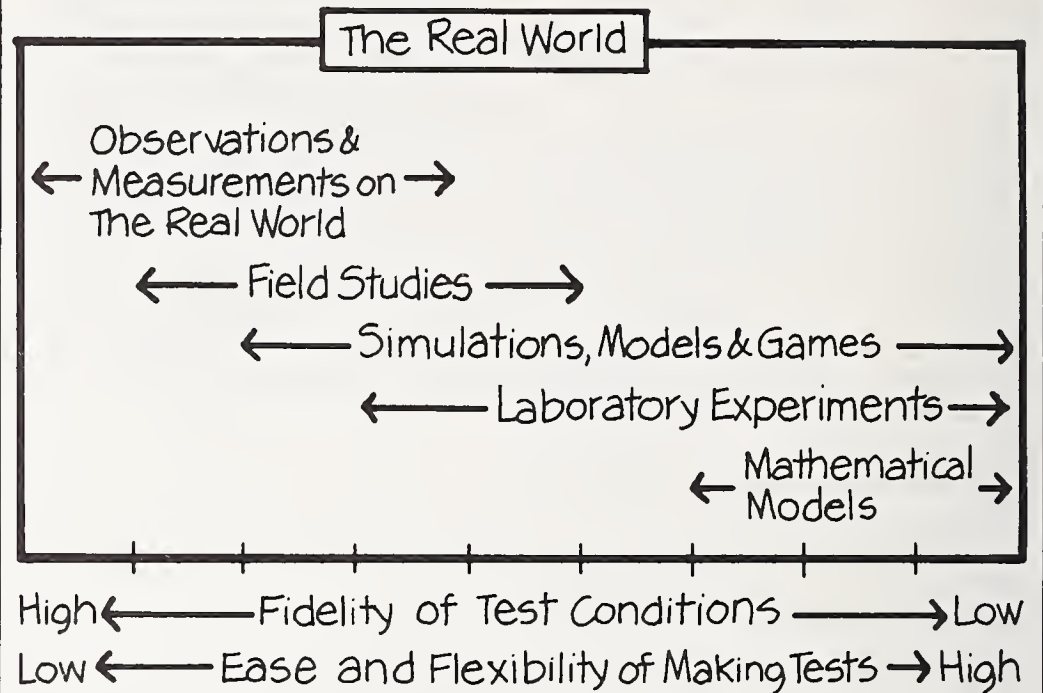

Methods of making observations can be considered from the viewpoint of the level of disturbance of the natural behaviors being examined, i.e., the extent to which an activity in an environment is disrupted by the presence of recording and measuring instruments and/or a researcher. Observational approaches share one characteristic—the need for a highly trained and sensitized experimenter, who can make relatively unbiased observations and measurements as inconspicuously as possible.

At the start of a study, while still defining the problem, the researcher may want to play the role of a **passive observer**, not altering any part of the environment, or intruding into the situation.

### Passive Observation

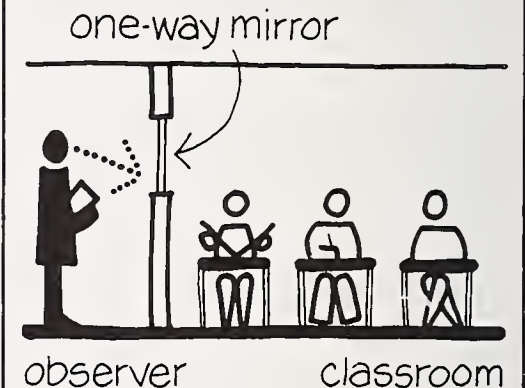



Consider a classroom. The experimenter is concerned with identifying critical environmental characteristics which might affect the performance of the teachers and/or the students. As a passive observer, the researcher would record data on natural behaviors with minimal interference (e.g., from behind a one-way mirror in a wall of a room). These behaviors are likely to be complex and hard to define. For example, the teacher could be observed "speaking to the class," "moving about the room" and the students could be "attentive" or "restless." In most instances, a limited number of subjects or activities is watched for relatively long periods of time. Since many events occur during such a situation, it is often difficult to obtain agreement among researchers as to what should be observed, or what records should be made of observations. Standardized procedures are developed to overcome this, together with careful selection and training of observers. Observations are generally made of public, natural and therefore highly visible events rather than private ones. After making a number of observations, particular activities and environmental characteristics might be examined, e.g., the effects of glare produced by sunlight on reading activities.

Modification of the passive observer technique is advocated by some researchers who employ observational methods. One such approach is to select a natural setting for observation and then introduce a logical and natural modification into the environment. Observations are then made under both conditions. One example is to substitute a round table in a conference room for a rectangular one and then determine the number of times people speak with one another. A refinement could be to replace the rectangular table to see if people then behaved as they did before the first change.

An extension of the systematic observation approach is for a researcher actually to serve as part of the environment being examined. This introduces a dynamic element into an experiment. The experimenter can move, or talk to subjects in a predetermined way, thereby studying behaviors in controlled social situations. For example, when designing public benches, researchers have seated themselves next to subjects to determine the separation distance typically desired by people (personal space). The researchers moved closer and closer to the person until the subject moved away. Information gained in this way can be used to determine the appropriate length of public benches designed to accommodate a given number of people. (See chap. 7.)

## Furniture Arrangement - Use Patterns

**Independent Variable:**  
The arrangement of benches in a park.



Arrangement A: 1 person



Arrangement B: 4 people

**Dependent Variable:**  
The number of people using the park benches

Finally, researchers have extended observational methods of collecting data to include information on what the subject's themselves observe as they participate in experiments. Devices recording eye movements; unobtrusive techniques such as television and film cameras are used; maps are drawn by subjects traveling along a prescribed route (see Parts II and III).

Observing people can raise ethical questions. E. Shils separates such ethical concerns into two parts: *First, the wrongfulness of any manipulation of subjects, and, second, the intrusion without a person's consent, or his knowing cooperation, into the reserved sphere of his individuality.*<sup>7</sup> In addition to the individual's right of privacy, one must also be aware of intrusion into the privacy of groups, communities, and organizations. The degree of privacy required will vary with the situation. No guidelines exist and each researcher must assess the ethics of particular research. Concern for this issue in the United States has led, however, to the review of behavioral research by formal panels in many organizations.

<sup>7</sup> K. A. Shils, "Social Inquiry and the Autonomy of the Individual," in *The Human Meaning of the Social Sciences*, ed. D. Lerner (Cleveland, 1959).



## Simulation Approaches

If we want to determine how people respond to a building, there is no satisfactory substitute for studying the building and how people use it. Often, this is not feasible. The most obvious instance is when a new building is being designed—you cannot observe a building that exists only on the drawing board. On other occasions, one research option is to examine an existing building which has many of the features of the one being designed, e.g., a school. Making observations of a “working” building has several drawbacks.

To overcome the objections cited in the accompanying table, researchers now have developed approaches which simulate the important characteristics of the environment they want to assess. Architects have used similar and often identical techniques for centuries, e.g., drawings, scale models, photographs. These and other more innovative procedures such as television and movie cameras are also used by researchers. While these procedures are designed to be relatively realistic (closely resembling the physical appearance of the environment being simulated) other simulations are highly abstract, such as mathematical models.

The philosophy underlying simulation is simple. If some part of the actual environment is simulated well (for example, a scale model may be used to represent an actual building), the researcher has the ability to control, to manipulate, to study and measure the conceptual model in a way that is not possible under actual conditions. Furthermore, under ideal conditions, the experimental findings obtained would be applicable to building design problems.

### Scale Models

Scale models are a very common means for simulating various aspects of the environment and may be full-

size or at a reduced scale. Designers often use them to represent a proposed building or a space within a building. The critical concern with models, as with other types of simulations, is the extent to which reaction to the model correlates with reaction to the actual environment. Scale models have been used in M/E research, as the following studies show.

In a study performed by the John Pierce Foundation, M. Blum (psychologist) and B. Candee (social psychologist) used scale model furniture to determine user requirements in the home. Furniture was cut from blocks of wood and arranged in a box divided into small compartments.

## Problems with M/E Field Studies-Observations of a “Working Building”

### Difficulty making observations:

The presence of observers may result in changes of activities

### Expense:

It is costly in terms of money and time - people and equipment must be on site; away from support staff and other research resources - e.g., data analysis equipment

### Limited number of observations:

The expense involved makes it difficult to observe more than a limited number of buildings, people and/or activities for abbreviated time periods

### Presence of uncontrolled variables:

Many things, other than building attributes are likely to affect the behavior of building occupants. For example, institutional and management factors may account for what people do, and these “variables” are likely to be unknown by M/E researchers.



Scale Model of High-Rise Buildings (EPA Documerica)



These items, together with pieces of white cardboard of various sizes to represent floor spaces, were presented to housewives, who were asked to arrange a bedroom exactly as they would like to have it, without considering expense. The subjects were then given the chance to add any furniture (and to identify it), and finally to indicate which furniture items would be excluded if they had to make a choice.

J. Lau (architect) studied full-size rooms representing single study-bedrooms and furnished them accordingly. Two rooms were then constructed at 1/6 the scale of these bedrooms. Subjects judged each of the rooms on the basis of "gloom" and "pleasantness," while varying the mounting position of lights, the type of light fitting and the luminous flux, each at two levels. Lau had this to say about the validity of scale model studies:

... it may be hypothesized that miniaturization does have an enhancement effect but it is not manifested when relatively simple assessments are called for. In such instances, observers appear to be able to "funnel" their critical ability to the task at hand. When the assessment required is of the "affective response" type and the observers' attentions are not directed to any specific point, then the validity of the use of scale models is questionable.<sup>8</sup>

<sup>8</sup> J. Lau, "Use of Scale Models as a Stimulus Mode," in *EDRA 2: Proceedings of the 2nd Annual Environmental Design Research Association Conference*, ed. J. Archea and C. Eastman (Pittsburgh, 1970).

## Photographs

Perhaps the most widely used simulation method relies on photographic procedures—slides, photographs and motion pictures. Studies using these procedures (and others) will be discussed in the latter parts of this work. For now, we will focus our attention on another question, the one raised by Lau, the *validity* of simulation methods. How well reaction to the real environment can be predicted by simulation is a question of quite recent vintage.

R. Abelson defines simulation as *the exercise of a flexible imitation of processes and outcomes for the purposes of clarifying or explaining the underlying mechanisms involved. Imitation per se is not the important feature of simulations, but rather that successful imitations may partially reveal the essence of the object being simulated.*<sup>9</sup>

Slides were used to determine response to the same environment with some of the major features altered by G. Winkel (psychologist), R. Malek, and P. Thiel (architects). Eighty observers—40 males and 40 females—were presented with black and white slides of roadside development along an urban highway. The slides were modified, through retouching, to eliminate certain undesirable elements such as billboards, utility poles, and other signs. After each set of slides was

<sup>9</sup> R. P. Abelson, "Simulation of Social Behavior," in *The Handbook of Social Psychology*, ed. G. Lindzey and E. Aronson (Reading, Mass., 1968), 2, 2.

## Example of Modified Slides (Winkel et al.)



Figure 1: No modifications



Figure 2: Deleted overhead wires, poles, & signs



shown the observer was asked to rate the route on a semantic differential scale.

R. Seaton and J. Collins (architects) used several simulation techniques in a study of the facades of four buildings. Judgments were made on the basis of full-scale model, color photograph and black and white photograph presentations. Ratings were made on five different 7-point scales and space was allowed for the subject to write in his own descriptions. In general, the findings were similar for all simulation techniques. *All buildings scored relatively high on tidiness and low on excitingness, irrespective of the simulations used. On the other hand, the relative pleasingness of the building clearly improved in its black and white rendering, and the same kind of observation can be made about other buildings' rankings on other dimensions in other renderings.*<sup>10</sup>

## Games

Games are a simulation method that is attracting the attention of M/E researchers. They are especially effective in promoting the interest of those who serve as experimental subjects because games are more enjoyable than most other methods used to collect information, such as completing a questionnaire.

F. Chapin (urban planner) devised a trade stamp game to be included in

surveys concerned with respondents' activities. The respondent is given a limited number of stamps to paste onto a game sheet. The game sheet indicates the choices available to the respondent for spending his leisure time. The game has an element of forced choice in that the player must accept the following preconditions: (1) he must use only a specified number of daylight and evening hours and (2) the rules specify the amount of time that may be spent for each activity.

The player first budgets leisure time for his present income and family situation; he is asked then to state how he would spend his leisure time under an assumed shorter workweek. Results can indicate the need for facilities both at the time of the survey and in the future.

Games are especially effective when complex problems with several competing points of view must be taken into account by the architect. This type of situation is exemplified by the following study. S. Cohn (urban planner) developed a game to analyze the process of adopting and applying architectural control devices (used to regulate the external appearance of communities and the urban environment). The process of establishing architectural controls involves five different groups—building applicants, review bodies, a legislative body, the general public, and a judiciary. These groups interact to evaluate proposed building projects.

Cohn chose his players from each of the groups listed above. Props included a mock architectural control ordinance (which varied from game to game) in the areas of community goals and values, standards of acceptance and judgment, decision making criteria, and quality of the application presented. A proposed building was simulated by means of architectural drawings, the quality of which varied greatly from game to game, and applicant information sheets. Designs ranged from very unattractive to award winning projects. Each project was placed on a site in a specific neighborhood by means of maps showing existing buildings and streets, photographs and written descriptions. Public interest was simulated through mock editorials, letters to the editor and other "open" information. The five groups then handled each application as indicated by a community's proposed architectural control ordinance.

Cohn anticipated that the variations provided would stimulate conflict and provide the researchers with an understanding of the most effective form of administration to employ.

Activities are observed in environments that are either natural or simulated. They are sometimes recorded permanently by television or film cameras; in other instances they are observed "live" and written records are maintained by researchers. The method used to make observations depends on the response being examined, which in turn is largely a function of the extent to which we know what to observe.

For example, in thermal comfort research, physiological measures (e.g., sweat rate, skin temperature) are frequently taken as response measures, since they have been shown to correlate with environmental factors defining the thermal environment. On the other hand, for many years researchers have been trying (with limited success) to find an adequate measure of "work productivity" to evaluate environmental conditions.

## Other Data Collection Methods

A researcher must often work closely with experimental subjects to obtain observations and measurements. One of the most widely used methods is the interview. This consists of a give-and-take between participants, which may vary considerably in terms of the degree of flexibility permitted. At times the researcher must closely follow a predetermined method and sequence of asking questions, while on other occasions, considerable freedom is possible in following up responses to particular questions as new information develops. Similarly, laboratory studies are sometimes designed so that the particular stimulus presented (e.g., light) depends on the response to a preceding one. For example, if we wanted to obtain an **absolute threshold** measure of a given light source (when the person reports seeing the light 50% of the time), we could employ an up-and-down procedure. This involves making the light brighter when the subject

<sup>10</sup> R. Seaton and J. B. Collins, "Validity and Reliability of Ratings of Simulated Buildings," in *Environmental Design: Research and Practice, Proceedings of the EDRA 3/AR 8 Conference*, ed. W. J. Mitchell (Los Angeles, 1972).



reports that it cannot be seen, and dimmer when the response is that it can be seen.

Some research approaches make experimental subjects responsible for providing data, with little or no interference from a researcher. Many questionnaires are largely self-administered, diaries of activities are kept by household members, subjects are asked to respond to checklists and other verbal (or equivalent) evaluative procedures. Several of the methods in common usage will now be discussed.

Semantic differential procedures, adjective checklists, diaries, mapping and other paper and pencil tests are among the other methods employed in M/E research.

One way to measure objective responses is to ask people to rate environments using adjectives which describe feelings. This appears to be a very direct procedure, and the semantic differential and adjective checklist approaches have been employed with increasing frequency by M/E researchers in recent years. In fact, R. Bechtel (psychologist) cites the semantic differential as the most widely used instrument in the study of subjective responses to architectural stimuli.

### Semantic Differential

The semantic differential measures the reaction of people to stimulus words and concepts in terms of ratings on scales defined with contrasting adjectives at each end.

This approach has the advantage of being very versatile. It has been used under a variety of conditions of interest to environmental researchers (outdoor scenes, rooms, lighting effectiveness, auditory environment, etc.). Bipolar adjective scales provide a simple, economical means for obtaining data on the reactions of people to their surroundings. The scales are flexible enough to be used by adults, children, and people from differing backgrounds and cultures provided that the words are familiar.

The semantic differential is used mainly to obtain affective (emotionally related) responses to complex situations, i.e., where many variables operate. Measurements of three dimensions are referred to as the profile of a concept (evaluative: good-bad; potency: powerful-powerless; activity: fast-slow).

The semantic differential was used by R. Howard (psychologist) et al. who compared subjects' ratings of actual buildings with their ratings of color slides and of black and white slides.

Using a 28-item semantic differential, subjects rated four buildings and six rooms within those buildings. To provide experiences comparable to the real environment, three to five slides were shown representing an expanse of about 150 degrees of visual angle. The rating was always made from the slide comparable to the major view seen by subjects in the real condition. The authors concluded that it is best to use real environments whenever possible. Slides produced less extreme and more negative responses than did the real environments. They also found little difference between the results obtained using black and white and color slides. Finally, they determined that the characteristics of the slides were important. The responses were more like those for the real environment when they were bright and sunny.

The semantic differential approach has its inherent limitations. The end product of such research seldom provides information in a form which can be readily applied to a design situation. Adjective data must still be interpreted for the architect to use in design. This approach has been seized upon as a fad by many researchers and employed in studies which are at best of academic interest. If used properly, the semantic differential can provide insight into how complex environments might be studied to identify major variables. Hypotheses may then be generated and tested using measurement methods linked to design attributes.

### Semantic Differential Analysis

#### Evaluation Dimension

beautiful	.....	ugly
pleasant	.....	unpleasant
harmonious	.....	dissonant
meaningful	.....	meaningless
cheerful	.....	sad
refined	.....	vulgar

---

#### Potency Dimension

rugged	.....	delicate
hard	.....	soft
tenacious	.....	yielding
strong	.....	weak
tough	.....	tender
masculine	.....	feminine

---

#### Activity Dimension

energetic	.....	inert
tense	.....	relaxed
dynamic	.....	static
interesting	.....	boring
warm	.....	cold
fast	.....	slow

---



## Adjective Checklist

The adjective checklist consists of a list of descriptive words which the respondent can check off as being either appropriate or inappropriate to the environment being considered. The adjectives are often listed with scaled space between each dichotomy in the same manner as the semantic differential. The adjective checklist has many of the same uses and limitations as the semantic differential. A more detailed examination of activities is possible using a diary.

## Diary

Using a diary technique each respondent is given a form on which to record designated activities. Records may be kept in one of two ways: (1) when a change in a designated activity occurs and/or (2) when break-points in the day occur such as coffee or meal breaks and prior to going to bed at night. An increasingly popular variation of the diary technique is the **time budget study** which involves the collection of information not only about activities undertaken but also detailed information about the time allocated for these activities. (Chap. 3 contains a discussion of the time budget study along with an example.)

M. Blum (psychologist) provides an example of the diary technique. He gave families logs on which to record activities performed in a 24-hour period. Every member of the family

was asked to keep a step-by-step record of all dressing and undressing activities and also the location in the house where these activities occurred. The results were extremely difficult to analyze and therefore were not used.

When diaries are used, special attention should be paid to their design. Differences between weekdays and weekends should be considered when examining activities. Another problem involves "placement" of the diary. For example, who is responsible for maintaining the diary within a family or other group. As far as completion is concerned, the researcher must be aware of the fact that the respondent may modify his behavior during the time he is keeping the diary. Also, since diaries often extend over long periods, some action usually must be taken to sustain the respondent's motivation. Finally, the illustrative material contained in diaries is often difficult to tabulate and process and the data provided by the diary may be hard to integrate with other research results. As with other forms of questionnaires, careful pilot work will help to locate many of these problems before the actual data collection begins.

The advantages of using a diary to collect data include the accuracy and reliability obtained due to the short time span between the activity and recording it. It is also possibly the only way to obtain accurate time-use data for periods of more than 1 day.

## Unobtrusive Measures

E. Webb (psychologist) et al. make the point that complex social research requires multiple study procedures. They note that since any one method is at best an approximation of the truth, problems should be attacked simultaneously in several different ways. Each single set of data can thereby serve as a means of evaluating the others. The authors describe approaches ranging from an examination of public records to the use of sophisticated apparatus to develop information. Their intent is not to endorse one or more of them, but rather to indicate their potential usefulness, when used appropriately with other measures.



*Example of Wear—Carpet (NBS)*

As an illustration of one source of information, they suggest examining noseprints on the glass of exhibits. The popularity of the exhibit could be measured by dusting the glass for noseprints at fixed intervals. An estimate of the age of viewers could be obtained by determining the height of the noseprint. Such estimates require verification by other more direct procedures, such as observation.

Another indirect means of determining usage is to examine the wear rate of materials. Many people have observed the fact that stairways, even those of stone, display signs of wear after many years of use. This is especially evident in historical structures which have been visited for centuries, e.g., the Parthenon.

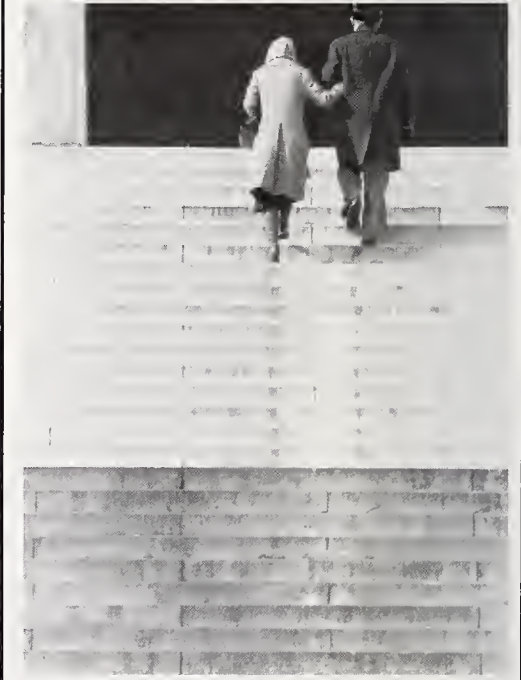

*Example of Wear—Stone Steps (NBS)*



Maintenance schedules contain information concerning usage. Webb et al. noted that vinyl tiles in front of a display of live, hatching chicks at the Chicago Museum of Science and Industry had to be replaced every 6 weeks while other tiles at the same museum lasted for years. That this was not a good indicator of the number of people who visited the display is suggested by the further observation that visitors stayed longer at the "chick" exhibit than at others.

Tile replacement schedules are likely to be recorded by those responsible for operating and maintaining public buildings. These and similar records are a potentially valuable source of information to solve M/E problems. For example, an examination of user complaints might offer valuable insights concerning the satisfaction of building users, although the potential presence of chronic complainers should be taken into account.

Records of accidents occurring in and around buildings can be valuable indicators of design deficiencies. Unfortunately, records contain very little information concerning the cause of accidents. The problem is documented in a report by B. Bloomfield and D. Hay. *It has been found that, first, accident data is focused largely on the effects (cost and degree of impairment) (economic or legal/medical) rather than on the cause. The variables may be quite unrelated. The state-of-the-art of estimating injuries from consumer products or in the performance of specific tasks leaves much to be desired.*<sup>11</sup>

Accident records have been compiled by the Consumer Product Safety Commission (CPSC) which has broad regulatory authority over products and hazardous substances. As a means of developing and organizing accident information, CPSC uses a complete system which is remotely linked to emergency rooms of 119 hospitals throughout the country. A Consumer Product Hazard Index has been produced by the system (National Electronic Surveillance System—NEISS; pronounced "Nice"). The index ranks many products in terms of the frequency and severity of accidents associated with them. Building features and materials are prominently mentioned among the 364 product categories listed.

<sup>11</sup> B. C. Bloomfield and D. C. Hay, *The Auditory Environment in the Home* (Milwaukee, 1971).

### Consumer Product Hazard Index (Consumer Product Safety Commission)

Rank	Structural Feature
2 . . . . .	Stairs, ramps, landing
3 . . . . .	Doors, other than glass
10 . . . . .	Architectural glass
14 . . . . .	Bathtub and shower structures
16 . . . . .	Swimming pools and in-ground equipment
26 . . . . .	Floors and flooring materials
33 . . . . .	Non-electric outdoor fences
40 . . . . .	Porches, balconies, floor openings and open-sided rooms
48 . . . . .	Outdoor structures, including patios, terraces, and retaining walls

### Robberies and Building Height (Newman)

Robberies per 1,000 Population

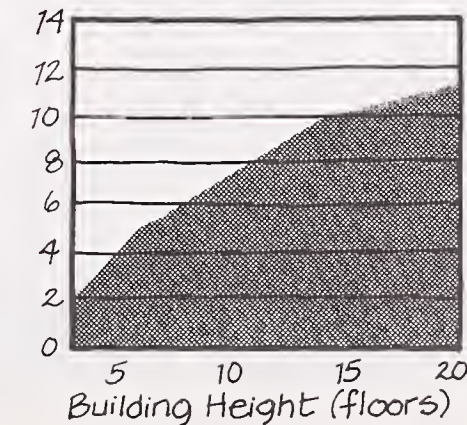

In his book *Defensible Space*, O. Newman (architect) examined records to explore the relationships between physical design and security in residential environments.

He used recorded data on crime, vandalism, and maintenance costs and interviewed inhabitants, project managers, and police. From these data he determined those characteristics which he felt contributed to criminal behavior.

Newman suggests the use of defensible space to combat these problems. He listed four architectural features which he feels contribute to secure residential environments:

- The residential environment should be divided so that residents adjacent to certain areas will adopt proprietary attitudes towards those areas.
- Residents should be able to survey both interior and exterior public areas from apartment windows.
- The building form should not be such that it portrays to outsiders a feeling of peculiarity and isolation.
- The development should be located in an urban area that contains similar types of construction as opposed to an area that contains activities which might provide a threat to residents.



## Characteristics of "High Crime" Architecture (Newman)

**Size:** Large Project; 1000 families or More

**High Rise:** More Than 7 Stories

**Separation:** Superblock, Closed to City Traffic

**Style:** Slab or Cruciform Towers

**Lobby Design:** Mailbox Area with 2 to 4 Elevators

**Corridor Design:** Long Double Loaded Corridor

**Stairways:** 2-4 Sets of Stairways, Running Full Length of Building With Separate Exits

**Grounds:** No Relationship to Particular Building

Newman concludes with a more detailed elaboration of these features. He indicates that a complex should be designed so that as few units as possible share a common street entry. Windows and entries should provide residents with a view of the project grounds and the street. Surveillance is then assumed by the residents in the natural flow of their everyday activities. This is what Newman has labelled **defensible space** design.

Many of Newman's concepts remain at the theoretical level. As more research is conducted, the validity of the concepts will be determined.

## Conclusion

Of the shortcomings evident in M/E studies, the most common one is the seeming absence of thorough preparation *before* conducting a study. This shows up particularly during the analytic phase of research, which often is wrongly treated as though it were independent of the data collection activity. Observations frequently are made with limited attention devoted to later requirements for analysis, interpretation, and application. For example, the most common M/E study is a questionnaire survey. Yet, survey data too frequently take the form of evaluating characteristics such as lighting and acoustics without specifying these features in physical terms, e.g., actual levels of light and noise. As a consequence, the results of these investigations cannot readily be translated into design decisions.

Sophisticated equipment such as video and film cameras to collect data and computers to process data frequently have a detrimental research effect. They enable researchers to collect tremendous amounts of information hoping that the relevant data have been thereby captured. Somehow, the only remaining task is to make some sense out of the data. The point that is frequently not stated (or overlooked) is that regardless of how data are collected they must later be analyzed and interpreted.

The technique of making extensive records of complex situations places a considerable burden on the researcher when the data are to be analyzed. For example, when hundreds of hours of videotaped data are collected, the analysis of these data will likely occupy several times that duration, if only because the researcher must learn what to look for. The ready access to enormous amounts of data can therefore be a mixed blessing to a researcher because it can mislead the researcher into thinking that data collection *per se* can be used as a substitute for thought.

After making the necessary observations, the researcher must determine how to analyze them—the computer will not do this for him. This analytic phase of research often proves far more costly than the actual collection of data, especially when a computer is involved. Researchers unfamiliar with computers often underestimate the cost and time required.

A more pragmatic research approach is to spend more time and effort in planning which data to collect, before embarking on full-scale data collection.



Community Separated from Surrounding Area (HUD)



**Collection and Analysis of M/E Data**  
(After Michelson)

Types of Data Collected	Sources and Nature of the Information	Input Media
<b>Activity data</b>	Coordinates for places actually used by single users and information of the frequency, intensity, length of use, etc. The data may be obtained from surveys or from direct observations.	<b>Punch cards</b>
<b>User data</b>	Information about the user (age, occupation, number of children, income, etc.). Coordinates referring to the dwelling of the user. The data are usually obtained from surveys.	<b>Punch cards</b>
<b>Demographic data</b>	Social and demographic compositions of geographical areas. In Sweden, such data can be obtained from official archives.	<b>Magnetic tape</b>
<b>Object data</b>	Physical elements represented by coordinates and numerical codes for their attributes. Data sources are aerial photos, maps, and blueprints; also data from registers and inventories.	<b>Punch cards</b>
<b>Road-selection data</b>	Information of how road nodes are linked to each other. Traffic regulations on different road links. Data sources are aerial photos or maps and inventories.	<b>Punch cards</b>



*Lighting Study—Needle Task (C. Crouch)*

*Extensive View (EPA Documerica)*



# 6

## Scales of Observation

The City—Macro Scale

Intermediate Scale—The Community, Neighborhood  
Access to Community Services  
Neighborhood Perception

Typical Scale—Buildings

Close Scale—Within the Home and at Work

Conclusion

The range and amount of potentially relevant M/E information useful to the architect is enormous. If we are to avoid being overwhelmed by the abundance and diversity of potentially useful data, we must devise a way to appropriately arrange this information. One way of organizing the diversity of material dealt with by an architect is in terms of the scale of observation. At times the breadth of view is extensive, looking outside of the building to the neighborhood and beyond. For work at this scale, the designer could examine the community where a building is to be situated and the relationships of the immediate neighborhood to nearby centers of activity such as schools, hospitals, shopping facilities, parks, and playgrounds. Another factor is the access of public transportation to nearby metropolitan areas.

A different perspective is from the interior of the building, determining the general relationships of rooms to one another, and the size and characteristics of common spaces such as corridors and building entrances. Emergency exit routes and spatial needs to accommodate furnishings and activities are typical of the problems examined at this intermediate scale.

Finally, many areas require a still closer look for reasons of safety, importance to the occupant, or the frequency of use. The activities performed in kitchens, workshop areas and bathrooms are typical of areas which merit such close scrutiny.

Consider a more specific example—the auditory environment of a residential multi-family building. Our initial interest might be the identification of site-related noise sources. Pertinent information might include data concerning nearby (and planned) airfields, roadways, and industrial plants. These data would consist of population density, movement patterns of ground and air traffic, as well as daytime and nighttime operations of all vehicles, of industrial plants and other facilities.

The environment being created by the building itself could then be scrutinized to determine whether substantial noises experienced in dwellings are due to the preliminary building plan. For example, if a courtyard is to serve as a recreational area, the designer may want to examine the types of activities that are to be accommodated, since many of them are likely to be noisy. Musical events could disturb some, and entertain others. Outdoor swimming pools encourage social and recreational activities that can be enjoyable or disruptive, depending on the viewpoint of the observer.

The next concern could be the residence of a single family. From a noise standpoint, there would be two major concerns for the family unit—freedom from noises outside the dwelling, and privacy within.

## M/E Disciplines and Observations—Macro and Micro

Scale	Discipline	What Observations Made	Typical Methods of Observation	How Results Organized Expressed	Purpose of Studies
Molar	Geography	Natural, manmade environmental features	Travelling over terrain, photographing at a distance	Map development	Description of environment for designers
	Urban Planning	Existing geographic and manmade features, human activities	Natural observation	Mapping of features, human activities—current and planned	Design of communities, consistent with natural environment and needs of population
	Sociology	Groups of people, behavior settings	“Naked eye,” questionnaires, motion pictures, photos	Tabulation of data, breakdowns by groups of population Correlating characteristics of people and group behaviors with built and natural environment	Describe characteristics of population
	Industrial Design	Operations of machines	“Naked eye,” complex instrumentation	Design drawings, product design	Improve performance of products from standpoint of users
	Human Factors Engineering	Man/machine interactions	“Naked eye,” photographs, movies, TV, complex instrumentation	Tabulations of data design drawings, sequences of behavior	Optimize human component of man/machine systems related to building design
	Anthropometry	Dimensions of people	Physical dimensions, measurements	Tabulations of data drawings of human dimensions	Provide information to designers concerning sizes of people
	Psychology	Individual performance visual, auditory, etc.	Judgments by subjects of differences, equalities (psychophysics), complex instrumentation, questionnaires, “naked eye”	Tables and graphs of human capabilities to see, hear—environmental stimuli	Determine psychological and sensory needs of individuals and relate them to design implications
Micro	Physiology	Neural impulses, sensory receptors	Microscope, complex instrumentation	Tables of data, structural drawings of eye, ear	Understand biological capabilities and limitations of humans and relate to design



Finally, we can focus on the family unit and the activities performed within the home. We could explore the individual needs of the members of the family for privacy and the pursuit of individual interests; and each activity might be affected by conflicting noise-producing activities such as watching television and listening to music. We would want to ensure that conversation could be conducted at normal speech levels. Another desirable goal would be to find out how to avoid sleep interruption by activities within and outside the residence.

A parallel can be drawn between the various perspectives of the designer and the subject areas investigated in several disciplines. Just as the designer employs several points of view, each appropriate to the examination of a particular aspect of the environment, disciplines can often be described on the basis of the scales of observation typically used. For example, *geographers* and *urban planners* (concerned with communities, cities and regions) operate with large (macro) scales of data. On the other hand, *physiologists* and *psychophysicists* who examine sensory and neural responses of people, work with data at the fine (micro) detail level.

Of particular interest to our present discussion is the number and variety of existing disciplines which have addressed problems linked to M/E studies. These disciplines have methodologies and measurements with the potential of being used (or modified) for M/E studies. They will be discussed in more detail in later chapters.

## The City—Macro Scale

A major concern of urban planners is that their efforts be translatable at the human scale—that the broad vision of the architect be understandable by the users of buildings. Mapping techniques have been developed to obtain insights concerning how natural and man-made environments are perceived.

K. Lynch (urban planner) was interested in the geographical and spatial orientation of individuals in a city and studied this by means of mental images depicted by citizens. His early interest was on city *legibility*, which he defined as *the ease with which its parts can be recognized and organized into a coherent pattern*.<sup>1</sup> He notes that although environmental images result from interactions between the user and the environment, he has restricted his initial concern to public images which ignore differences among observers. The environmental image has three components: *identity* (an individuality all its own), *structure* (a relationship of the object to the observer and to other objects) and *meaning* (some practical and/or emotional consequences for the observer).

<sup>1</sup> K. Lynch, *The Image of the City* (Cambridge, Mass., 1960).

Lynch sought to identify physical qualities which relate to the identity and structure of the mental images. He used the term *imageability* in defining that quality in an object which can be related to the evocation of a strong image in any given observer (shape, color or arrangement). In analyzing several cities he used a two-step procedure. A field reconnaissance of the area was made by a trained observer, who made detailed maps and evaluated environmental features using methods prescribed by the investigators. Lengthy interviews were then conducted using a sample of city residents. They were asked to describe their environment, identify locations and make sketches. The procedure included the planning of imaginary trips using all available information.



Macro Scale (HUD)

Subjects were asked to:

- Provide a set of complete directions between home and place of work.
- Make a sketch of the city and local areas within.
- Describe emotional feelings associated with certain landmarks or areas.
- Indicate the most distinctive elements in the city.

As a follow-up to the interview, photographs of their own and other cities were presented to several subjects. They categorized photographs in any way that appeared meaningful and were then asked to identify them, indicating the cues used for identification. Finally, the subjects were asked to place the photographs in a map of the city in appropriate locations.



F. Ladd (urban planner) employed a similar technique in studying the way that black youths view their environment. She had subjects verbally describe their environment and then asked them to draw a map. The maps were analyzed and placed into one of the following four categories based upon content, format and degree of sophistication:

- Pictorial representations of houses, buildings, and other street elements with little context provided.
- A schematic representation of several independent places; no clear interconnections between sub-areas within the map.
- Many features of a map without identifiable landmarks.
- Resembling a map, containing identifiable landmarks.

A game which simulates some of the conflicts and frustrations experienced in city planning was devised by D. Godschalk. A low income housing project was to be developed near two middle income subdivisions. The game consisted of the interaction of representatives of the low and middle income groups, with the city planner present as technical expert and social arbiter. The group's goal was to arrive at a recommendation for the City Council.

## Direction Finding - Different Mental Maps

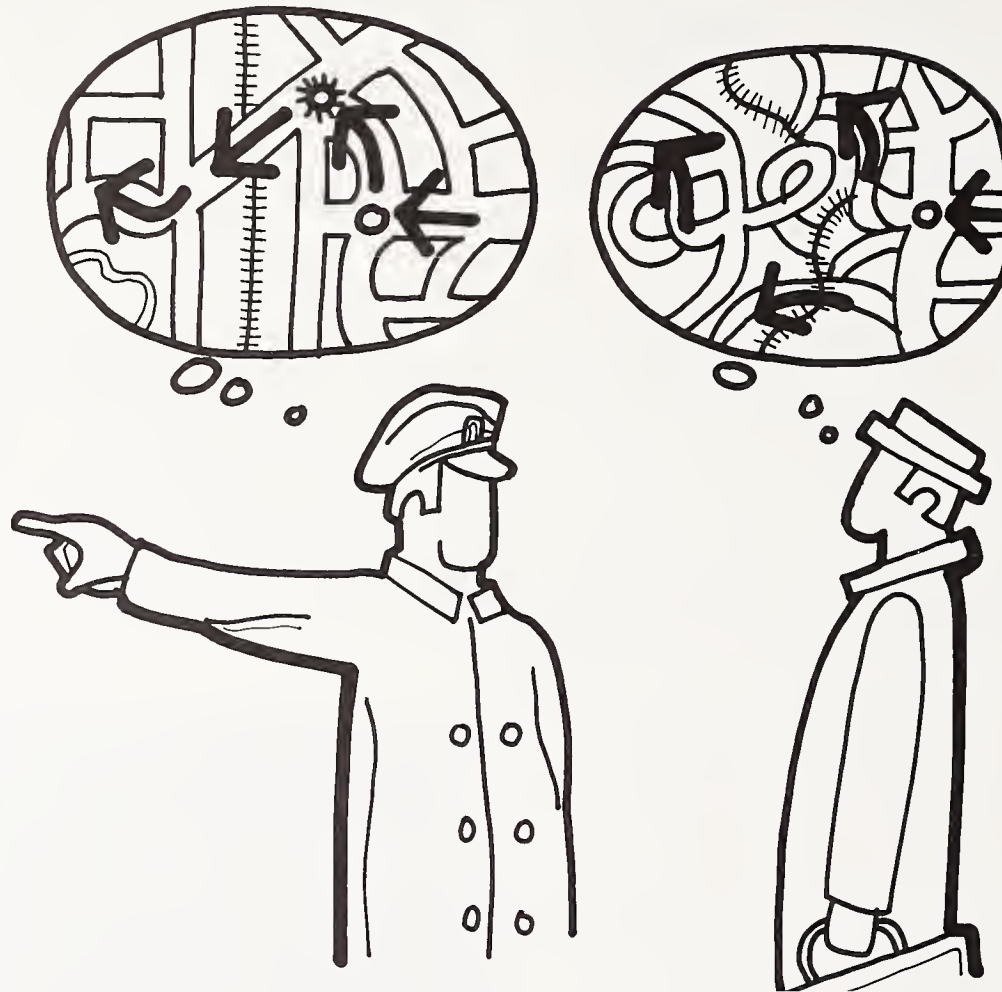

The game equipment consisted of a three-dimensional scale model of the project site and surrounding area showing roads, buildings, and topographic contours at a horizontal scale of 1 in.-100 ft. (2.5 cm-30 m) and a contour interval of 10 ft. (3 m). A zoning ordinance and map and a set of drawings showing the project site plan, building plans, and elevations were also provided to subjects.

Representatives from the low income group made up one team; the middle income group formed the other team. The two teams were asked to discuss their differences about the project; they were also asked to agree upon a recommendation for the City Council as to whether or not it should be built, and if so, whether or not any changes should be made in the plan or conditions attached to its approval. No other explicit directions were provided. The planner (experimenter) used a prepared list of technical rebuttals to the most common objections to the project (land use arrangement; traffic congestion; property value decline; school overcrowding; separation of low income residents from their friends and community facilities). The game was thought to be an effective means of involving users in the planning process.



While a city or neighborhood is usually thought of in visual terms, we also experience our surroundings by means of the sounds heard. The next study to be examined dealt with both visual and auditory perceptions of a city. We will limit our discussion to the noise environment.

M. Southworth (urban planner) undertook a study which explored perception of Boston's "soundscape." The study explored two questions: (1) What is the perceived variety and character of city sounds? (2) How do sounds influence perception of the visible city? Southworth hoped to identify areas which should receive further attention from researchers and urban planners.

To investigate changes in the soundscape over time and under varied weather, the researchers took five subjects on wheelchair trips through various parts of the city. The subjects were blindfolded and the trips took place at different times on different days of the week. From this phase of the study the researchers were able to determine (1) the uniqueness of certain sounds in the urban environment and (2) how well a sound conveyed the spatial form and activity of a particular location.

In the second phase of the study, Southworth studied the interactions between the auditory and visual environments. Three groups of subjects made the trip through the city on a

Saturday. The groups were (1) *auditory subjects*—could hear but not see (2) *visual subjects*—could see but not hear and (3) *visual auditory subjects*—had normal vision and hearing. A 2 3/4 mile (4.4 km) trip was mapped out which included settings with a variety of sonic characteristics, visual activity, and spatial form. The subjects were given tape recorders so they could record impressions. At the conclusion of the trip the participants were asked to draw a map indicating the sequence of places visited and to describe the most and least liked settings.

An analysis of the interactions between the visual and auditory environments indicated that without sound visual perception has less attention-demanding qualities and conveys less information. Southworth suggests two steps toward improving the city soundscape. The first would be to reduce and control noise and the second would be to increase the amount of information provided by city sounds.

### Temporal Change in Sounds (Southworth)

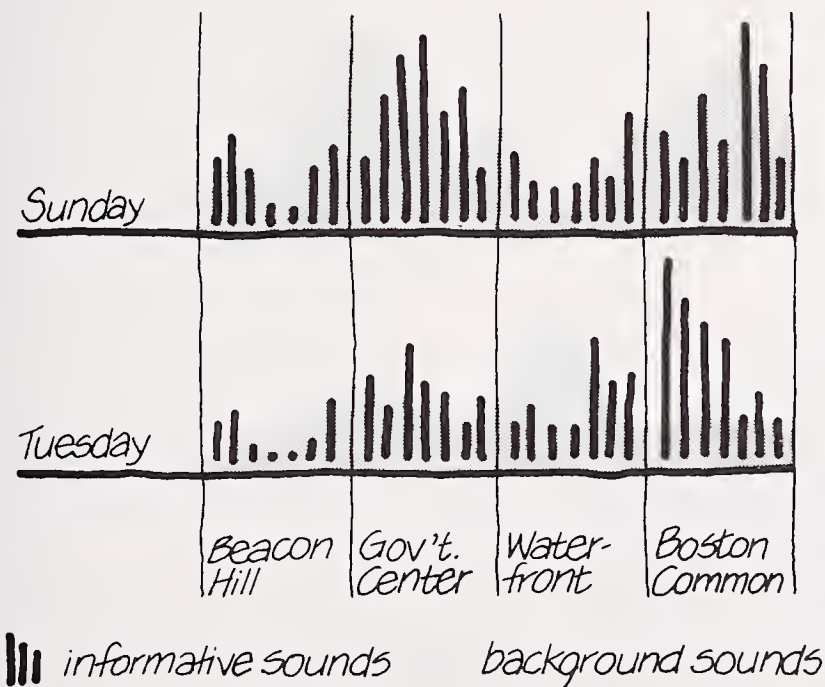

### Variety and Frequency of Mentions of Sound (Southworth)

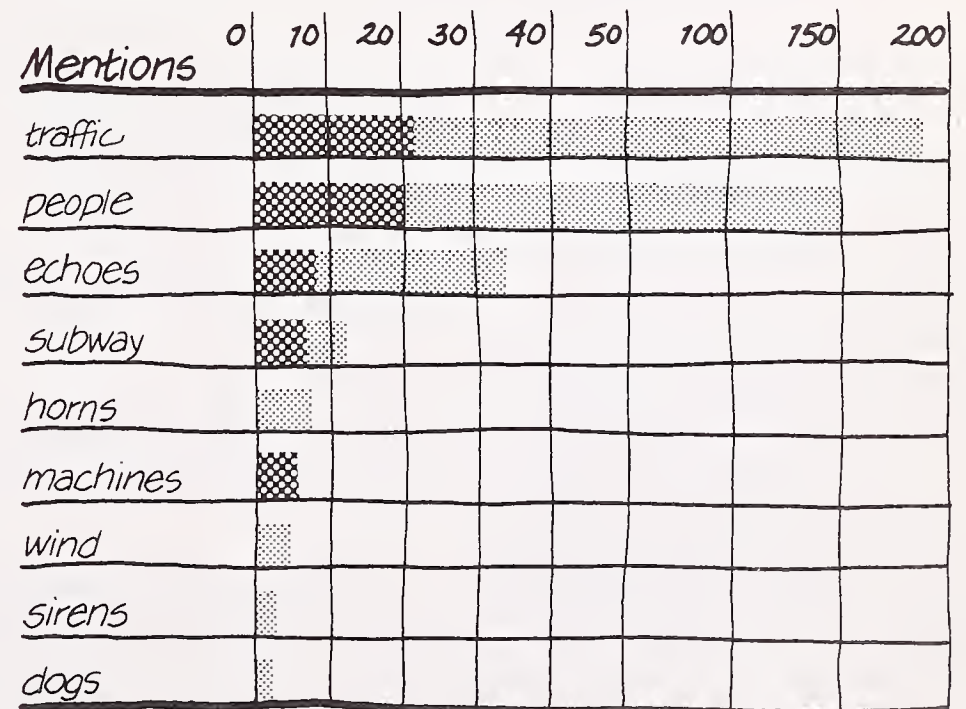

■ mentions by visual & auditory subjects  
 ■ mentions by auditory subjects

## Intermediate Scale—The Community, Neighborhood

While a region or city provides a backdrop for many things that we do, most activities are performed closer to our homes—in communities and neighborhoods. It is therefore not surprising that many M/E researchers have studied how people relate to their nearby surroundings.

One area studied is the access to community services by residents.

### Access to Community Services

One approach has been to discover how people judge apparent distances in an urban setting. R. Lowrey (geographer) first found out how familiar people were with a set of facilities in a community (shopping centers, bus stops, libraries, hospitals, etc.). He then obtained estimates of distance from subjects and finally compared these subjective distances against actual distance measures. He used two techniques in obtaining measures of subjective distance. The subject was asked to rate the convenience of the facility (from his home) on a 5-point scale ranging from very convenient to very inconvenient. A **paired comparison** test was administered for distances to all facilities, based on a scaling of length of line.

## Game Board (Wilson)

POLICE	ELECTRICITY	STREETS	TREES
police within 3 minutes 3 \$100	wires underground 7 \$450	paved 17 \$400	shade trees 25 \$150
sheriff on call within 30 min. 4 free	wires on poles 8 \$350	gravel 18 \$300	along street 26 \$100
		dirt 19 \$50	

Sample of items used to estimate importance of utilities and services.

R. Wilson (sociologist) included two games in his survey of user requirements dealing with services and utilities by residents of the Durham and Greensboro, North Carolina

areas. In each game, players were told that they had won a house on a television program and that they liked the house and it served their needs well. The house had not yet been built,

however, and the sponsor wished to obtain information about preferences for utilities and services before choosing an appropriate neighborhood. In the first game the player was presented with 34 items, each of which had a dollar value attached. Markers were used to represent an amount of money (markers totalling \$2,000 were given to players in Greensboro and \$1,800 in Durham) with which the player purchased those items he wished to have. A purchase was made by placing a marker of the appropriate value in the correct space on the game board.

### Paired Comparison Test for Distance Estimation (Lowrey)

1. If this is how far it is from your home to a hospital:

2. Mark with a straight line and appropriate letters how far it would be to a:

SL School  
GA Parking Garage  
PK Park  
PO Post Office





The second game dealt with preferences for neighborhood density and travel distances and times to certain neighborhood and community facilities. Each player was given a specified number of markers (36-40). The markers had no monetary value but served simply to limit the number of choices available. The player first had to choose one of the density categories at the top of the board thus using from 6 to 30 of his markers. He then used his remaining markers to indicate the number of facilities desired and at what distance. Facilities further from his home required fewer markers. Thus, he would have a few facilities quite close or a large number of facilities some distance away.

Another game by R. Worrall et al. is based on the theory that an individual evaluates neighborhood facilities around his home—shops, parks, fire stations, transit-stops, etc.—in terms of two competing objectives. The individual wants such services convenient and close at hand. At the same time, he may wish to avoid the noise or traffic delays which accompany the activities performed in the facilities.

The authors of the study indicate that:

*The result, in terms of his locational preference, is a tradeoff between a desire for easy accessibility and a complementary desire for insulation.<sup>2</sup>*

<sup>2</sup> R. Worrall, G. Peterson and M. J. Redding, "Toward a Theory of Accessibility Acceptance," in *EDRA I: Proceedings of the 1st Annual Environmental Design Research Association Conference*, ed. H. Sanoff and S. Cohn (Raleigh, 1970).

## Examples of the Results of Locational Preference Game (Worrall et al.)

### Shopping

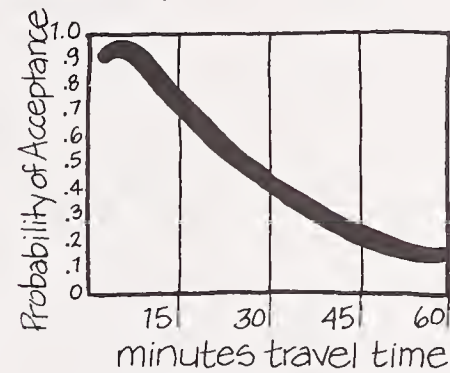

### Close Friends

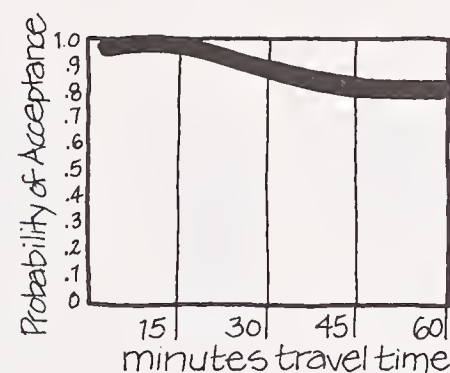

### Public Transportation

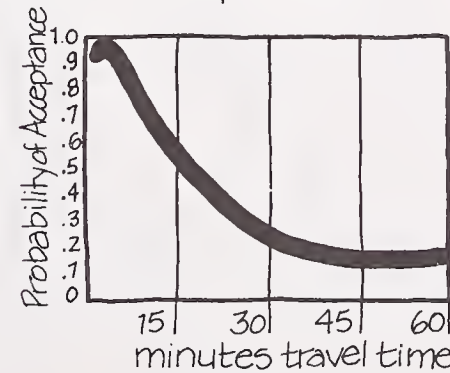

This tradeoff was measured by having 240 families indicate desired locations for eight neighborhood services with respect to their homes. Each respondent was asked how far in terms of travel time (assuming use of the most convenient travel mode) he would like each service from his home. Respondents were then asked whether successive increases in the distance of each service from their homes were sufficient to cause their home environment to become unacceptable. The minimum and maximum travel times were recorded.

## Neighborhood Services (Worrall, et al.)

### Number/Service

1. local shopping centers
2. church or place of worship
3. children's park
4. fire station
5. emergency hospital
6. entrance ramp to metropolitan freeway system
7. stop or station on metropolitan transit system
8. close friends' homes

## Neighborhood Perception

While Lynch and others have studied the city and other large-scale environments by asking experimental subjects to draw maps, similar approaches have been used to determine how people perceive their neighborhoods.

Photographs may also be used to determine the perception of residential neighborhoods. G. Peterson (civil engineer) asked 140 subjects to rate 23 photographs on a scale for each of 10 variables. The photographs represented a variety of residential neighborhoods and included both spatial and other variations. The photographs were projected in a darkened room on a 50 in. by 50 in. (127 cm by 127 cm) screen. Research subjects were asked to rate each photograph in terms of such factors as: preference, greenery, age, open space, safety, and privacy. The findings were interpreted by Peterson to mean that the "general physical quality" of the neighborhood was of greatest importance.

## Typical Scale—Buildings

Many M/E studies deal with building features. An often cited study is the work of W. Ittleson, L. Rivlin, and H. Proshansky (psychologists) describing behaviors in a psychiatric ward. A mapping technique was employed to collect information, but the maps were constructed by the researchers, based on systematic observation of behavior. In this study the researchers made observations on three different hospital psychiatric wards. The first stage of the study consisted of observations of behavior, which were then grouped into a set of categories. The second stage involved counting the number of times that each categorized behavior appeared during an observation period.

In the Ittelson study, trained observers recorded the behavior of male and female patients, staff and visitors. Observations were made every 15 minutes and were scheduled to last no more than 3 to 4 minutes. Recordings were made at predetermined physical locations and involved the number, description and location of participants engaging in the specified categories of behavior.

A. Esser (psychiatrist) et al. also developed a method for mapping the behavior of patients in a hospital psychiatric ward. Observations were made from a booth with one-way glass centrally located on the ward. The floor of the ward was divided into 3 ft. by 3 ft. (0.9 m by 0.9 m) grids. Observers in the booth had plans corresponding to the actual grid system. Every 1/2 hour a recording was made of each individual's location and the direction in which he was facing. In addition, the following information was coded on the map: postural position, activity or work in which engaged, whether or not interaction was taking place, and if so, with whom. Patients were observed continuously for entire days and their behavior was recorded. Only half the patients were observed to use the space available to them; the others occupied very specific territories. The authors felt that these results were useful in the design of hospital wards and in the study of various theories of personal space.

### Close Scale—Within the Home and at Work

Since people spend most of their time at work or at home, many M/E researchers feel that the development of a better understanding of these environments is their first task.

While for the most part, the collection of information is the responsibility of researchers, several M/E techniques ask those being studied to help collect information. There are advantages and disadvantages to this approach. A major advantage is to increase the subjects' interest and motivation. A problem is the need for the participant to collect information at appropriate intervals and the willingness to make the effort to follow instructions and reduce errors.

Photography has been a favored means of collecting all types of M/E information. C. Perin (anthropologist, urban planner) used this approach to provide information for a questionnaire. She gave cameras to four families and asked them to take pictures of activities within their homes. In the first steps of the study, the families were instructed as follows:

*The only "direction" to follow in taking the first 50 pictures is that they should be of ways in which you live in your house. That means the bed will be unmade sometimes, dirty dishes in the sink, children's toys spread around, the newspapers all over the floor, people barefoot, hair uncombed, and so on.*

*You are not being asked to take a picture of anything you consider to be private, and you will have the right to remove from the study any picture you choose.<sup>3</sup> The families were allowed to keep the instamatic cameras and were also paid for their participation.*

In the second half of the study specific photographs were requested. A. *The first type of picture is the place where something goes on. Please take pictures of these places: where the family meals are eaten; where meals with company or extra guests are eaten; bathroom; sleeping place of each family member; place where guests are put up; playing space for children of each age, alone and with others; studying place of children; reading place of adults; telephone place; writing place; laundry drying places for big and small washes; storage places; kitchen trash and garbage; any other places in the house you want to include.* B. *The second type of picture is of the steps you take in doing things. The pictures should show at least three things: The beginning of the activity (for example, getting ready to do it by taking things out of storage), doing it (bending over and scrubbing, or typing), and finishing (putting things away).<sup>4</sup>*

Perin then discussed the photographs with the families. This allowed her to view and discuss activities within the home without actually being present and risk disrupting activities.

### Distribution of Territories on the Ward (after Esser)

Date: \_\_\_\_\_  
Time: \_\_\_\_\_  
Number: \_\_\_\_\_

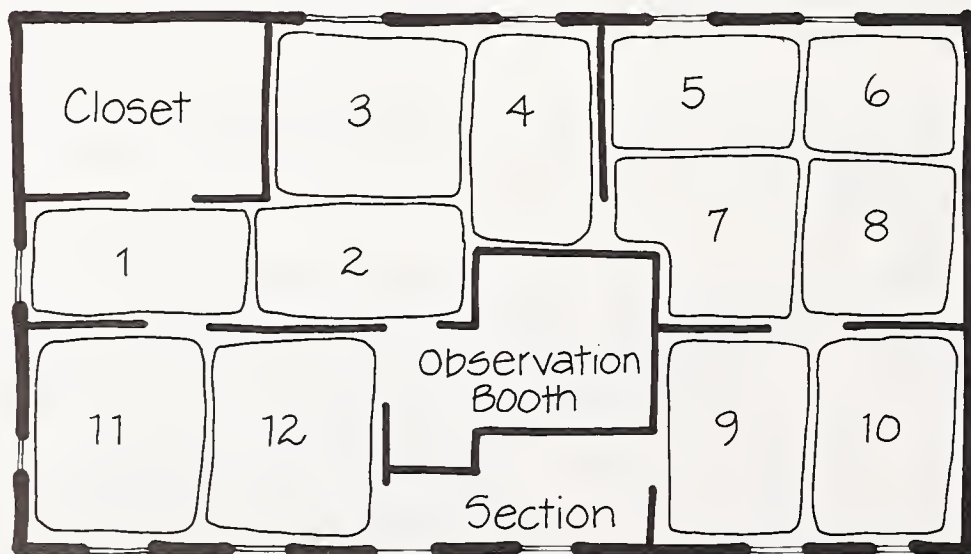

<sup>3</sup> C. Perin, "Concepts and Methods for Studying Environments in Use," in *Environmental Design: Research and Practice, Proceedings of the EDRA 3/AR 8 Conference*, ed. W. J. Mitchell (Los Angeles, 1972).

<sup>4</sup> Perin



E. Grandjean (Swiss ergonomic researcher) has specialized in **ergonomic** studies of the home and has synthesized a large body of work indicating preferred dimensions for work and other areas. Most of the work deals with observations made at the close scale.

One problem attacked by Grandjean and his colleagues was to determine the appropriate characteristics of a

drawing board. Three subjects were photographed while working at different sections of the drawing board. The subjects were all males; one short, another tall and the last of medium height. The photographs were later analyzed to determine the bodily attitudes assumed when performing their tasks. Of particular interest to the researchers were (1) the angle between the axes of the head and back and (2) the slope of the back away from the vertical plane.

### Drawing-Boards and the Postures Adopted for their Use (Grandjean)



Grandjean discusses his own work and that of I. Astrand while describing the relationship of physiological measurements to the performance of activities in the home. Astrand had subjects perform several household tasks, while measuring pulse rates as an indicator of the physiological difficulty of performing these activities.

Before the household tasks were undertaken, a standard task was performed (riding a bicycle) and measures of pulse rates, oxygen intake, and lung ventilation rates were taken. The pulse rates for the household tasks could then be correlated with the other physiological measures.

### Pulse Rate as a Measure of Household Activity (In Grandjean)

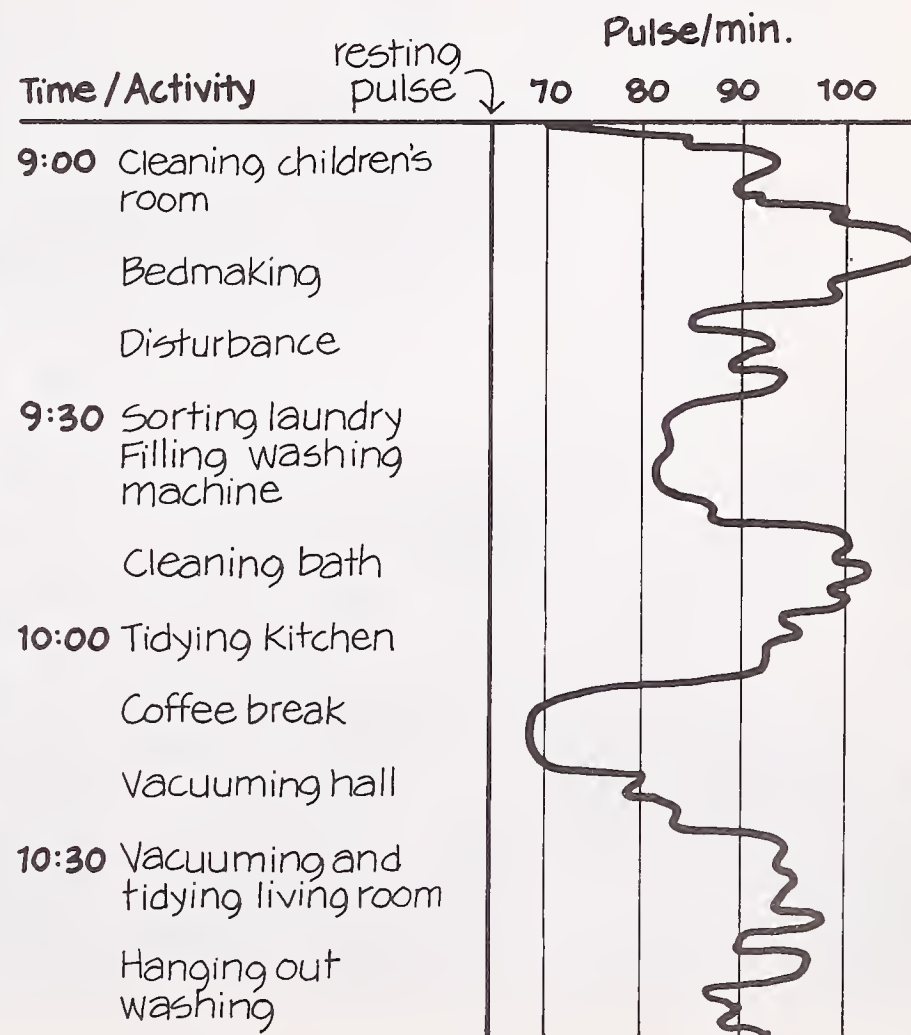

In a sense, physiological data constitute the closest scale of observation in M/E research. They frequently provide information not available by other research procedures. They offer the added apparent advantage of being "objective," and not subject to many of the errors typically associated with behavioral research. (The objectivity of the data, however, depends on the relevance and adequacy of the measures, which are often difficult to establish for M/E problems.)



*Research Apparatus*

*Physiological Measures of Eye Movements (R. Harquail)*

## Conclusion

This review of the several scales of observation needed to solve M/E problems concludes the present part of the study. We first stressed the need to use the observational and measurement methods developed in the classical science disciplines for improving the information available to building designers. These approaches were then discussed in the context of building user studies. Our intent in this part of the work was to provide an overview of the subject matter of M/E research, a suggested approach to solving problems and a sampling of the methods available for collecting information concerned with building users. Next, we will explore in greater depth the variables which should be dealt with by M/E researchers and discuss more research methods typically used to collect information.



*Data Printout*

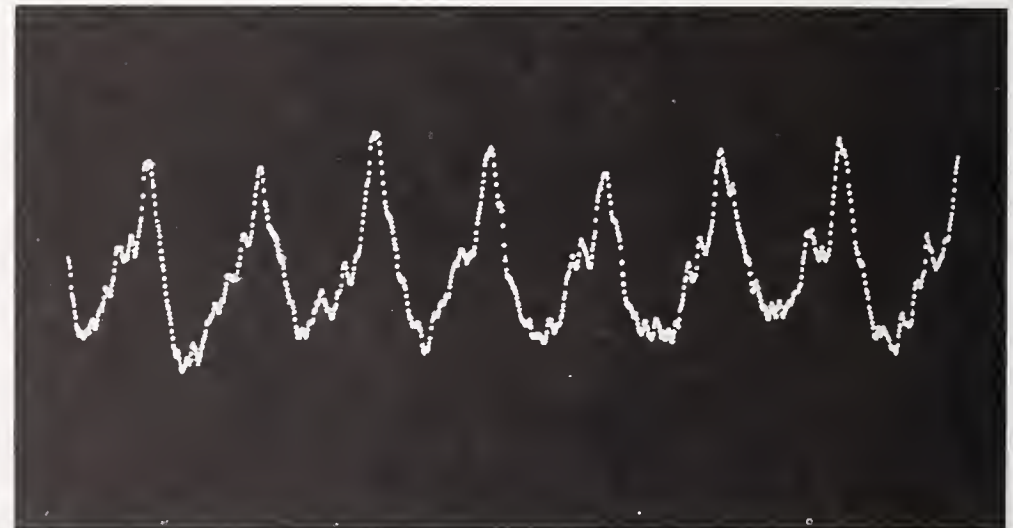

*Data Printout*



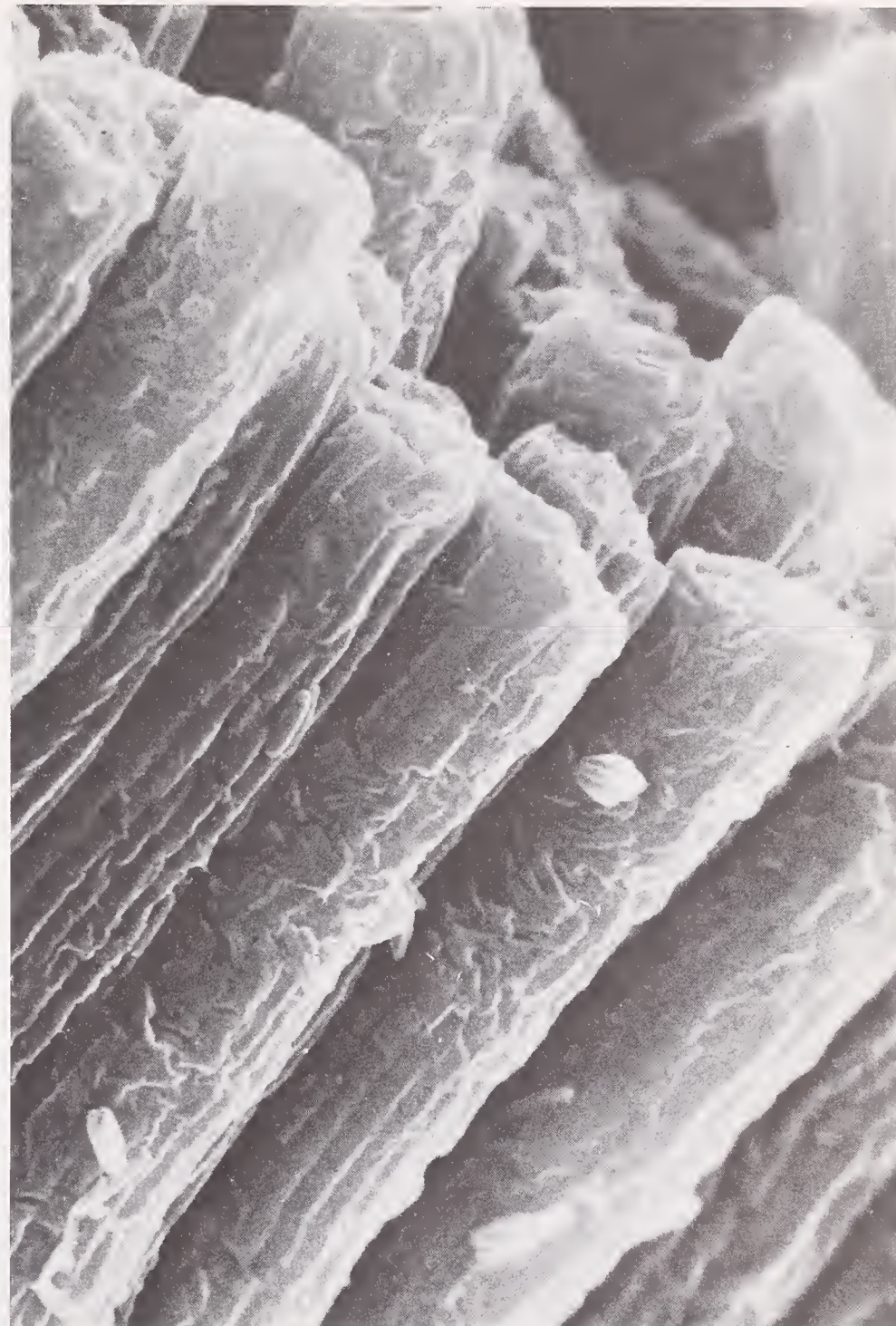

*Electron Microscope Photographs—Visual Receptors of the Frog (J. Danielson)*

*Cones*

*Rods*







# Part III

## Man/Environment Research— Components and Characteristics

Now, having provided a general overview of research procedures, and those used in the M/E study area in particular, we are ready for a more detailed examination of M/E research. Our intention is to familiarize the reader with the ways available to obtain better M/E information. Studies have been selected from many sources to suggest the broad range of approaches available to the researcher. While research findings are included in this and later parts of the work, they are not emphasized since our intention is not to compile a source book of findings. Rather, we want to point the way toward collecting appropriate and reliable data. Another reason for not stressing research results is that a major shortcoming evident in M/E studies is the lack of adequate documentation describing the procedures used to collect research data. Without this information, it is virtually impossible to know whether the studies conducted were performed with adequate scientific rigor, i.e., minimizing experimental error. Consequently, those who read such reports cannot judge whether the findings should or should not be accepted as good information.

In Chapter 7, our concern is to explore the issue of differences among individuals as an important M/E consideration. The differences examined include physical, personal, social and cultural factors which point to the need for the architect to go beyond the consideration of the "average" person as the user of buildings.

Just as we recognize that people display an enormous range of differences, many building types also exist. They frequently demand separate examination in terms of M/E implications. While some activities are common to all buildings, building types often support unique activities (e.g., hospitals).

Chapter 8 consists of an examination of M/E factors which cannot be readily separated. The primary emphasis here is on activities conducted during normal use situations and those which are carried out under special circumstances, such as during emergencies. Two classes of activities are considered. First, those which require people to interact with permanent features of a building (e.g., stairs). The other activities discussed are those where a person interacts with objects within a building (e.g., furniture).

Chapter 9 discusses research focusing on building features such as windows and ceilings. The investigations were performed to clarify the influence of design features on the behavior and/or attitudes of occupants.

### Classes and Types of M/E Data

Classification	Types of data required
<b>Individuals</b>	Capabilities-limitations Similarities-differences Likes-dislikes
<b>Interactions Man</b>	Space (movements) Machines, objects (appliances, furniture) Environmental stimuli (light, heat, sound) Complex systems (communication)
<b>Activities (Behavior settings)</b>	Dining Shopping Working Enjoying recreation
<b>Environmental Features</b>	Building elements (windows, railings) Building systems (elevators) Spatial configurations (rooms) Materials (texture)



*Crowd (Kalett, J., People and Crowds. New York: Dover Publications, Inc., 1978.)*



# 7

## Man

### Cultural, Social, and Personal Factors

Territoriality

Personal Space

Social Distance

Crowding

### Physical Attributes of People—Anthropometry

Special Groups—The Aged and Handicapped

### Effects of Past Experience

### Conclusion

Recent attempts to develop user requirements as a basis for physical design in building reflect the desire for a more rational approach in the light of the increasing complexity of the problems involved in design and the increasing separation between designer and user. In seeking for hard data it is understandable that physical determinants such as anthropometrics and ergonomics, as well as comfort needs with regard to light, heat and sound should until recently have received more attention than topics within the more complex socio-cultural and psychological realms. Even physical standards which might be regarded as "hard" and quantifiable data are themselves affected by cultural attitudes and social forces prevailing at the time and place of their inception. Such standards, in common with most human activities and institutions, are the result of a combination of constant and variable factors. In the area which we are discussing, the constant aspects which set certain possible ranges and limits are man's physiological and anatomical characteristics, while the variables are culturally defined choices. It is not, of course, our intention to deny the need for the existence of standards and ranges of acceptability and non-acceptability but rather to suggest that the physical determinants of built form are a more complex and subtle matter than is commonly accepted.<sup>1</sup>



*Differences Among People (HUD)*

<sup>1</sup> A. Rapoport and N. Watson, "Cultural Variability in Physical Standards," in *People and Buildings*, ed. R. Gutman (New York, 1972).

It has become commonplace to say that buildings are built for people. What is meant by this statement?

We may consider people from the viewpoint of the average person or from the differences apparent among them. Architects and researchers, depending on the particular situation, are called upon to use both perspectives in their work. The viewpoint selected is a major determinant of the kind of information needed, thereby influencing the way that research is performed.

Typically, behavioral researchers working on sensory problems, such as auditory and visual research, have focused on the common biological heritage of man, much of which is shared by other animal species. (This study area will be discussed in Part IV.) Researchers concerned with understanding why people behave as they do, start with the premise that people are motivated by similar psychological influences. The work of Sigmund Freud is representative of the approach which seeks to understand the subconscious experiences of people by employing a variety of research methods.

On the other hand, M/E theorists and researchers have investigated the effects of social influences on the individual's use of space. K. Lewin (psychologist) provided the theoretical framework for many such studies (e.g., territoriality, crowding).

His conception was that all psychological events such as thinking and engaging in behaviors are part of a **life space** which consists of the person and the environment, viewed as a constellation of interdependent factors. Individual psychological processes are always to be derived from the relation of the "concrete individual" to the "concrete situation." He further noted that an understanding of behavior requires not only a knowledge of the person (past experience, present attitudes and capabilities) but a knowledge of his immediate situation. Research should therefore be designed to study psychological events from the standpoint of the many factors which influence a person—physical, social, and personal.

Naturally, the physical requirements of building users are of critical importance in design. A considerable body of information has been developed which results from measurements of large numbers of people while at rest, and when participating in activities. These data vividly demonstrate the need for architects to consider differences among individuals in the design process. As we shall indicate, differences are not merely physical in nature, but also attributable to cultural and psychological influences.

### Cultural, Social, and Personal Factors

Earlier we indicated that although buildings are often designed with the average person in mind as the user, M/E researchers agree that buildings

should accommodate cultural, social, and personal differences found in the user population. Different backgrounds and experiences can exercise important influences on how people respond to their environments. It is only by means of a thorough examination of these differences that user requirements responsive to building designs can be specified. Knowing something about individual differences enables statements to be made about the distribution of the population of responses to

design features; determining what proportion of a large group of people are likely to respond in particular ways to attributes of a building. As an illustration of this point, A. Rapoport (architect) and N. Watson conducted a review of physical standards used for building designs in a number of nations. They particularly noted that national standards governing the same aspects of the built environment (e.g., space, lighting, noise, etc.) often

### Population Sizes and Weights (Selected Samples By Authors) (Roberts)

Group	Number in Sample	Weight (kg)	Stature (cm)
<b>African</b>			
Kikuyu	436	51.9	164.6
Efe	386	39.8	143.8
Baya	412	53.9	163.0
Bahutu	216	56.7	165.9
<b>American</b>			
Zuni	348	56.3	161.4
Hopi	276	60.8	161.1
Eskimo	121	62.1	159.3
Maya	70	53.7	156.4
<b>European</b>			
England	3000	64.5	166.3
Iceland	652	68.1	173.6
France	2619	67.0	172.5
Bulgaria	121	67.1	167.2
<b>Asian</b>			
China	351	54.0	165.0
Korea	594	59.2	163.2
Indian	1193	52.7	165.8
Sudanese	200	51.4	159.9



**Recommended Lighting Levels (in LUX\*)—Cultural Differences**  
(Rapoport and Watson)

	1 U.S.A.	2 Gr. Britain	3 France	4 Germany	5 Sweden	6 Finland	7 Belgium	8 Switz.	9 Australia
<b>Most Difficult Seeing Tasks</b>									
Finest precision work. Involving: finest detail; poor contrasts; long periods of time. Such as: extra-fine assembly; precision grading; extra-fine finishing.	10000— 20000	1500— 3000	1500— 3000	4000	1000— 2000	1000— 2000		over 1000	over 2000
<b>Very Difficult Seeing Tasks</b>									
Precision work. Involving: fine detail; fair contrasts; long periods of time. Such as: fine assembly; high-speed work; fine finishing.	5000— 10000	700— 1500	700— 1500	600— 1000	300— 500	500	500— 1000	300— 1000	700— 1500
<b>Difficult and Critical Seeing Tasks</b>									
Prolonged work. Involving: fine detail; moderate contrasts; long periods of time. Such as: ordinary benchwork and assembly; machine shop work; finishing of medium-to-fine parts; office work.	1000— 5000	300— 700	300— 700	250— 500	300	300	250— 500	150— 300	300— 700
<b>Ordinary Seeing Tasks</b>									
Involving: moderately fine detail; normal contrasts; intermittent periods of time. Such as: automatic machine operation; rough grading; garage work areas; switch-boards; continuous processes; conference rooms; packing and shipping.	500— 1000	150— 300	150— 300	120— 250	150	150	100— 250		150— 300
<b>Casual Seeing Tasks</b>									
Such as: stairways; reception rooms; washrooms; and other service areas; inactive storage.	200— 300	70— 150	70— 150	60	40— 80	80	50— 80	40— 80	70— 150
<b>Rough Seeing Tasks</b>									
Such as: hallways; corridors-passageways; inactive storage.	100— 200	30— 70	30— 70	30	20	40	20— 30		50— 70

\* LUX = Lumens per square meter

differ from country to country. They illustrate their point with the following example:

American standards recommend a minimum width of 5 ft. 4 in. for two people facing each other in a dining booth. This dining pattern is not shown at all in Indian data, but for two people facing each other across a dining table the American dimension is 6 ft. 2 in., while in India it is 5 ft. 6 in. (i.e., 8 in. less). The Indian data show additional requirements for eating in a squatting position (6 ft. 6 in.) and also distinguish between informal and formal situations with different dimensions, both for dining at a table and in a squatting position.<sup>2</sup>

Rapoport deals extensively with cultural influences on house design in another work in which he hypothesizes that house form is the result of choice among existing possibilities, the greater the number of possibilities, the greater the choice, but there is never any inevitability, because man can live in many kinds of structures.<sup>3</sup> For example, the degree of choice open to a builder in the United States is considerably greater than that available to someone building in the polar region. In this investigation Rapoport attempted to find house features which seemed to be universal, to identify critical differences in house forms, and to try to relate both sets of characteristics to personal and cultural factors among populations.

<sup>2</sup> Rapoport and Watson

<sup>3</sup> A. Rapoport, *House Form and Culture* (Englewood Cliffs, N.J., 1969).

Although we are dealing with M/E issues, we should not ignore the fact that man exists in a psychological environment as well as a physical one. Determining the relationships of these two environments has been of major interest to both theoreticians and researchers. One area where this concern has been displayed is the study of how people use space, with respect to social interactions and the performance of solitary activities.

E. Hall (anthropologist), like Lewin, makes the point that individually determined space factors play an important role in any study of distance relationships among people and for animals as well. Hall was an early proponent of the need to consider cultural variability in the use of space, privacy, overcrowding, and other important M/E concepts. Hall studied the problem of distance relationships by observing activities and developing a classification scheme to describe them.

In common with Lewin, his starting point was the individual, who may be considered from the standpoint of being encased in an invisible bubble which defines his boundaries. The boundaries of the bubble go beyond one's body, and its dimensions depend on the many factors already noted. The bubble then serves as a reference point for the individual (or group), and distances may be described as they relate to the bubble.

## The "spatial bubbles" of Hall

public domain	(12+ ft.)
social-consultative	(4-12 ft.)
casual-personal	(1½-4 ft.)
intimate	(½-1½ ft.)

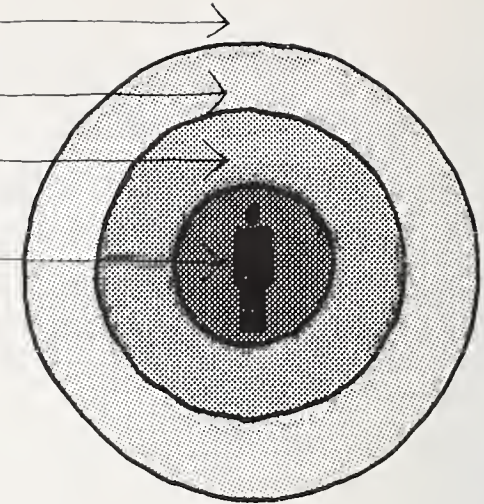

Life space and the invisible bubble may be considered as theoretical models developed to describe requirements for individual privacy, and/or the need for freedom of the person (or group) from unwanted intrusions from others. Studies of territoriality have addressed this issue.

### Territoriality

In chapter 6, when we discussed the scales of observation employed in M/E studies, we provided a number of examples of territorial studies. We will therefore limit our present treatment of the subject.

The work of J. Crook (animal researcher) illustrates a research approach to better define the distance classifications developed by Hall. Crook recorded three types of spacing—*arrival distance* or how far from several birds a newcomer will land, *settled distance* or the resultant distance after adjustments and *distance after departure* or how far apart birds remain after intermediate birds have left. Similarly, N. Russo



(psychologist) noted that a number of flight reactions occurred when she maintained an *arrival distance* of about 6 inches (15 cm) (moved her chair when the subject did) and did not allow subjects to establish a comfortable *settled distance*.

J. Anderson (geographer) and M. Tindall studied territoriality in young adults. The participants were given the following instructions:

*From memory draw a sketch map of your childhood (ages 6-12 yrs) turf. By turf we mean that area or set of areas which you traversed, occupied, or used with sufficient regularity and assurance that you considered it for all practical purposes to be the proper domain of you and your friends and/or siblings. The sketch should show major and minor paths, activity models, and landmarks as well as "verboten" or danger areas, important barriers and boundaries, and include a legend. Scale and orientation shown may be relative and need not be precise. Then, write a two to four page analysis, exploring the nature of the patterns of movement and activity revealed by your sketch maps and their determinants.<sup>4</sup>*

The researchers view this approach as a tool for helping them to understand how people perceive and relate to their environments. Anderson and Tindall hope that an understanding of these concepts will lead to better planning and design of community facilities.

<sup>4</sup> J. Anderson and M. Tindall, "The Concept of Home Range: New Data for the Study of Territorial Behavior," in *Environmental Design: Research and Practice, Proceedings of the EDRA3/AR 8 Conference*, ed. W. J. Mitchell (Los Angeles, 1972).

### Example of "Turf Map" (Anderson and Tindall)

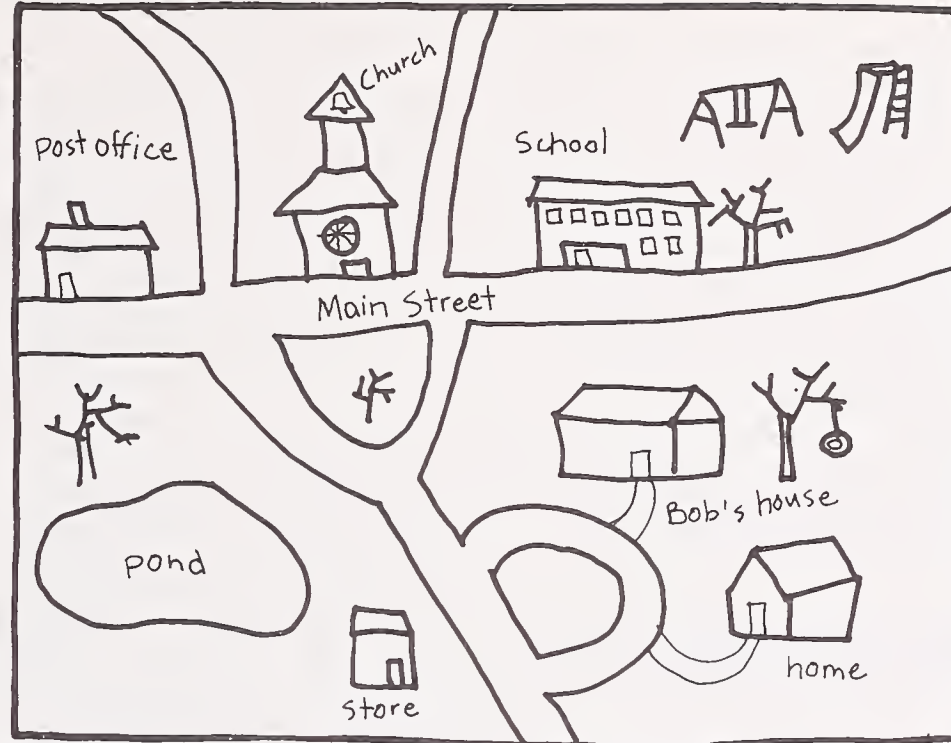

#### Personal Space

R. Sommer (psychologist) developed the concept of **personal space** which defined distance relationships between people. Sommer's approach is similar in several ways to the concepts of Hall, but his approach is more systematic, i.e., research oriented. His technique was to employ people and environmental features to collect objective data in social situations. The author was a **participant observer** in a mental hospital study. He identified a park bench that was used by the patients and employed the bench as a research tool to test dominance behavior. When he noticed a person seated alone on the bench, Sommer seated himself nearby, on the same bench, and deter-

mined how closely he could approach the other person before the patient left. He then made measurements of the distance between himself and the other person at their closest approach. He also instructed subjects to become friendly with a person seated on a bench and recorded the distances between the two participants.

When hospital administrators complained that the patients on a psychiatric ward did not interact with one another very frequently, Sommer rearranged the chairs, which had been placed in a straight row, so that they faced one another. The number of verbal interactions that occurred using each of the seating arrangements was then recorded.

Russo employed a participant observer approach in a study conducted in a library, in which she seated herself at various locations in the proximity of students. She recorded behavior in order to determine when subjects acted as though their space had been invaded, by moving away from her when she encroached upon their territory.

#### Participant Observation (Sommer)

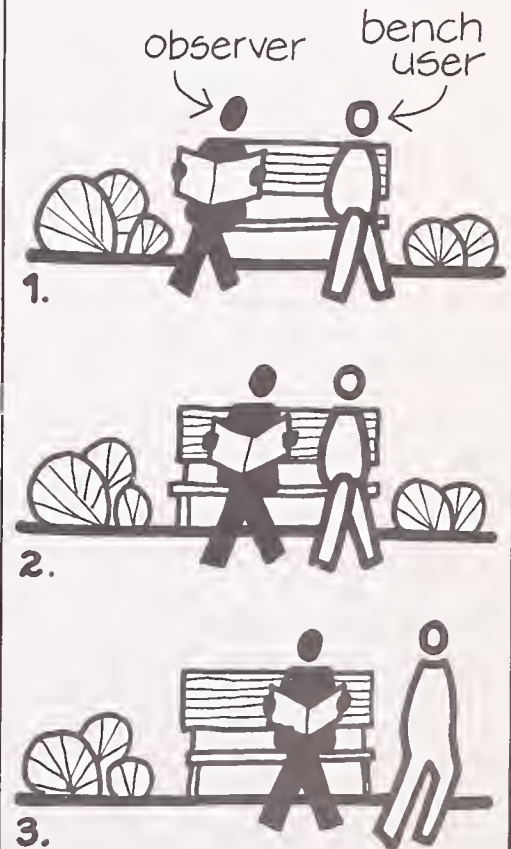



J. Dabbs (psychologist) et al. conducted an experiment designed to measure comfortable distances for conversation at different locations within a room. An office with sparse furnishings and about 12 ft. by 15 ft. (3.6 m by 3.9 m) was used as the setting. College students served as subjects and participated in team pairs. The subject approached his partner until he felt the distance between them was comfortable for conversation. The partner stood either in the center of the room or in the corner with his shoulders touching both walls. Then the subject stood in the center of the room or in the corner and was approached by his partner until the partner was told to stop. The results indicated that greater distances were maintained when one subject was in the corner of the room than when both subjects were in the center. These findings emphasize that measures of personal space may be affected by differences in setting as well as by interactions between setting and other variables.

An experiment to determine the effects of sex and race norms on personal space was conducted by M. Liebman (psychologist). She used distance measures as described previously but employed a more sophisticated experimental design than her predecessors. The experimental area was furnished as a waiting room which was occupied. There were three experimental conditions. One was free seating where subjects could sit on a 6-ft. (1.8 m) bench which was already occupied.

The second condition consisted of a choice of two 3-ft. (0.9 m) benches each containing one person. Finally, the subject could select one of the two 3-ft. (0.9 m) benches with only one of the benches being occupied. The investigators systematically selected the characteristics of the occupants on the bench(es), e.g., in some instances the race and/or sex was the same as that of the subject and in other instances, they were different. Distances between the subject and the "confederate" were measured and provided the basic experimental data. The author found that race and sex were often important factors in determining space usage.

### Personal Space Study (Holahan)

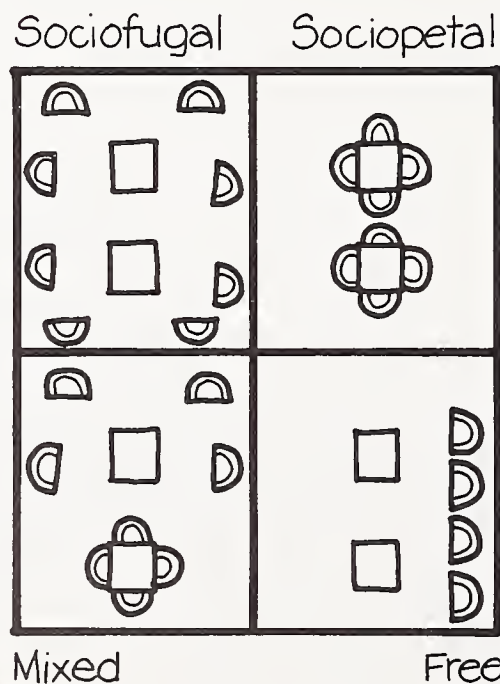

Other experimenters have also used furniture arrangements as a means of determining personal space preferences. C. Holahan (psychologist) conducted a study investigating the effects of seating arrangements on the social behavior of psychiatric patients. There were four experimental conditions: chairs were arranged shoulder-to-shoulder along the walls of the room (*sociofugal*); chairs were arranged around two small tables in the middle of the room (*sociopetal*); chairs were arranged both along the walls and around a small table in the middle of the room (mixed); patients were told to arrange the chairs themselves in any manner they wished (free). Subjects were told not to rearrange the chairs in all but the free condition. An observer was present in the room and recorded each subject's behavior every 75 seconds during the 45-minute session. At the completion of the experimental session each participant was given a map of the room and asked to draw eight chairs in what he felt would be the best arrangement. Results indicated significantly less social interaction in the arrangement with the chairs placed shoulder-to-shoulder along the walls of the room (*sociofugal*). The free situation also precipitated a surprisingly low level of interaction. Both the experiment and the maps indicated that the patients preferred the chairs arranged around the small tables (*sociopetal*).

Another approach dependent on furniture arrangements is the open space concept used in many schools. Teachers and students are encouraged to move furniture. Observations and measurements are then made, which consist of records of physical arrangements and behavioral descriptions.

P. Williamson (psychologist) reported on an observational study of the use of space and furniture by both teachers and children in an open space classroom. She was particularly interested in looking at the behavioral differences between problem and nonproblem children. Two techniques of observation were used. In the first, an observer concentrated on one child and at 30-second intervals recorded the following information: the child's location, the size of the group he was with, his posture, his activity (based on 24 predetermined categories) and the names of those with whom the child was interacting. In the second type of observation, the observer mapped the location of furniture and located all individuals in the room. This was done every 5 minutes. The results indicated general spatial and behavioral patterns which existed across classrooms of similar design. The nonproblem children used space in a manner similar to the teachers, that is they tended to use the front and central portions of the room. The problem children, on the other hand, spent a large amount of time on the edges of the room.



Social factors may influence a person in subtle ways. As a result, it is sometimes useful to employ measures such as physiological changes when social factors are believed to be important. One study demonstrating this approach was performed by G. Evans and R. Howard (psychologists) who wanted to determine whether the proximity of a researcher to a research subject would affect physiological and psychological behavior. Tapes of randomly-selected numbers between 1 and 64 were prepared. The subject was instructed to classify each number as either high and odd (odd numbers greater than 32) or low and even (even numbers less than or equal to 32). An experimenter sat directly in front of the subject at varying distances. Error rates were recorded along with the subject's galvanic skin response (GSR) (measure of electrical conductance of skin). At the conclusion of each group of numbers, the subject completed a *semantic differential* (see chap. 5 for description of semantic differential) for the following adjective pairs—"secure-scared," "calm-nervous," "relaxed-stressed," "involved-detached," and "steady-jumpy." The results indicated a general increase in errors when subjects were closer to the experimenter and the GSR rates showed generally lower resistance as the subject moved closer to the experimenter.

### Social Distance

Our discussion of distance relationships has been largely confined to individuals. However, the architect must also be concerned with how groups relate to one another. A method initially developed to study industrial and management problems is also useful for M/E research. It is called **sociometry** and provides one means for obtaining information dealing with the links between social interactions and environmental features.

Sociometry is a method of determining the structure of social relations among members of a given group. A sociometric test measures the preferences or rejections expressed toward members in a group.

Most sociometric tests are administered as questionnaires designating choice situations. These questions have two characteristics:

- A specific criterion for the preferential choice is used, based on the functional activity of the group and the hypotheses being tested (such as, *With whom do you like to eat, socialize, etc.*).
- The number of choices allowed varies according to the size of the group.

The original method described by J. Moreno (sociologist) involves drawing a **sociogram**, a diagram which represents the choices made by the members of a group. The more frequently chosen individuals are located near the center and the isolates are placed on the periphery. Preferences or rejections are represented by lines between the individuals. Sociograms are used mainly with small groups for diagnostic purposes. Matrix analysis makes it possible to analyze more complex interrelationships.

B. Wells examined the relationship of office design to interactions among employees in order to determine the cohesiveness of work groups in a large British insurance company. He compared friendship choices among workers in a large open area and among workers in smaller enclosed areas.

Wells administered a sociometric test to 285 general clerks by means of tape recorded instructions and slide projections, the responses to which were written in a booklet. Comparisons were made between the open areas and the small partitioned offices in (1) the number of choices directed outside of each section, (2) the number of reciprocated choices within each office and, (3) the number of people who seldom interacted with others, i.e., isolates. The findings indicated that choices were directly related to the distances between employees and that group cohesion was greater in the smaller offices than in the open plan sections.

### Sociogram (Moreno)

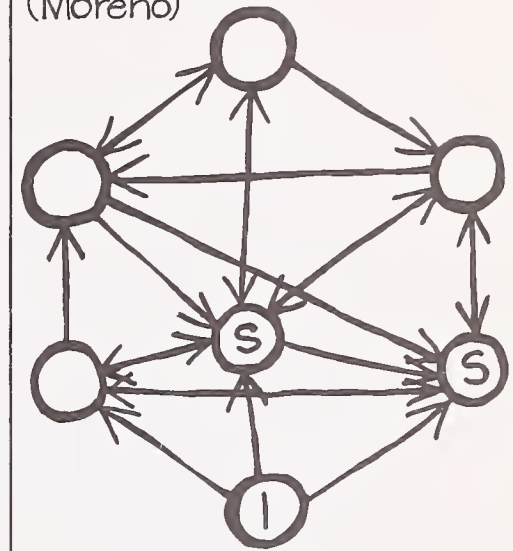

### Simple Sociometric Diagram

7 Subjects

21 Preference Choices

6 Mutual Preferences

2 Stars

1 Isolate



With the average life expectancy increases notable in recent years, and considering the already sizable group of elderly people, the question of the relationships between the aged and the population at large has been raised by many social scientists and planners. Two opposing viewpoints are apparent. One contends that old people prefer to be among those with similar interests and concerns and therefore should be housed in buildings suitable to their special requirements. The opposite viewpoint is that the aged should not be isolated, rather, they should be integrated into the community. Major design implications are associated with these or alternative approaches.

E. Steinfeld (architect) used three-dimensional scale models in conjunction with interviews to assess attitudes of older people toward increased contact with young children. Models were used which represented three different activity settings—a park (recreation), a community center (social meeting) and a neighborhood (housing).

The park was used to measure desirable proximity in terms of the physical distance to children. Three benches were positioned with identical surroundings (tree, walk) at three different distances from a playground for children. It was explained that each of the benches was exactly the same walking distance from the point at which the walk diverged. Respondents were then asked to indicate at which bench they would want to sit if they were walking into the park alone or with a friend.

The community center was used to measure desirable proximity in terms of accessible distance to children. It was explained that the three models represented three different ways in which a community center could be built to house a nursery school and a senior citizens' activity center. The differences in accessibility were also explained. In one model one group would have to go outside to visit the other. In another model they would both share a reception room and could visit without leaving. In the final model the groups had separate entrances but could choose to be together in the middle room if they so desired. Respondents made two choices and the pattern of their preferences was recorded. The pattern of choice as a whole was used as an indication of preference.

The neighborhood models were used to measure desirable proximity in terms of the degree of age-segregation of older people in the settlement pattern. Four cards were prepared with six plastic model houses on each, arranged on both sides of the street on individual lots. Each neighborhood or block had a different mix of senior adults and families with young children. Respondents were asked to choose the block on which they would like most to live and the block they would like least.

The findings indicated that on the whole the respondents preferred close physical distance to children in the recreation setting and neighborhoods with a high density of older people.

L. Pastalan (psychologist) reports a study that indicates the importance of keeping established relationships when individuals are relocated. He used two facilities in his study on the effects of relocation on nursing home patients. The **control setting** was a county medical facility which remained essentially unchanged for the duration of the study. One **experimental setting** was a county medical facility which was being closed down. Patients were moved to an existing facility. The existing building was totally different, the staff did not move, and the patients were integrated with the existing patient population. The second experimental setting was a facility which was moving from an old building to a new building on the same site. Patients and staff structures remained essentially the same.

An additional study was carried out in the second experimental facility. One group of patients was taken on five advance visits to the new building and in addition given problem solving tasks and spatial orientation sessions. A **matched group** of patients visited the new building once and were presented with slides of the new facility. They also had staff visits and group review sessions. In all cases the effects of relocation were measured by the patient mortality rate. Results indicated a significantly higher mortality rate for patients in the first experimental setting.

## Crowding

The focus of attention on the decay of many large cities has led to speculation by urban planners and social scientists on the relationship of crowding and human behavior. While, not long ago, population density was thought by many to be synonymous with crowding, studies by Rapoport and D. Stokols have differentiated between these concepts. The major distinction is that while density is often defined objectively—i.e., "number of people per unit area," crowding is largely a subjective concept, which resists such a simple definition. These authors point to major cultural differences among people which affect their perception of being crowded. For example, although Japan is one of the most densely populated areas in the world, traditions and life styles have intensified the feelings of being crowded.

Most of the experimental work pertaining to crowding has been done in animal laboratories using small mammals. J. Calhoun's (biologist) work with rats is the most prominent research in this area.

In his original experiment, Calhoun confined a population of rats in a 1/4-acre (1/10 hectare) enclosure. Within this enclosure there was an abundance of food and of places to live, predation was eliminated and disease minimized. The only factor remaining which could significantly influence the size of the population was the behavior of the animals toward one another. The population stabilized at 150 adults although the observed



reproductive rate led researchers to postulate that the environment could support a population of 5,000. The researchers discovered an extremely high rate of infant mortality caused by a lack of appropriate maternal behavior. Apparently the population of 150 adults was so high that social interactions became very stressful.

Calhoun conducted other studies in which populations of rats were allowed to increase to twice the size that would normally occupy a given space. Through careful observations, the researchers were able to determine those changes in behavior which resulted from the increased population density. Many of the behavioral changes were observed among the females—litters were not carried to full term and proper maternal care was not given to those babies who did survive. Males displayed sexual abnormalities and behavioral disturbances ranging from overactivity to almost total withdrawal.

The work of Calhoun is thought by some planners and researchers to be applicable to human populations, while others are dubious about its relevance to urban problems. The opponents of this viewpoint stress that there are many other factors (e.g., economic, social) which affect behavior, while the supporters of the research point to the biological similarities between man and animals. In our view it is premature to either accept or reject the conclusions drawn from this work.

A limited number of research studies using human subjects has dealt with crowding behavior. A. Baum and G. Davis (psychologists) employed a simulation approach to study the phenomenon of crowding. They employed model figures made from clothespins, which were placed in scale model rooms to arrive at a definition for crowding. The researchers systematically varied the

color and complexity of the rooms, as well as the activity being simulated.

Four scale model rooms were used in the study. Two rooms contained pictures to add to their visual complexity, while the other two rooms had walls which were covered only with paint. Two rooms were painted with dark colors, the other two with light pigments.

The research subjects were instructed in one of two social orientations. (1) *Imagine that this room is a lounge where people are standing and talking at a cocktail party, and that you are there* (2) *imagine that you are in a lounge area of an airport where people are standing and waiting between flights, and that you are there.*<sup>5</sup>

One clothespin figure was then designated to represent the participant, who was asked to place himself in the room, and then add additional figures *until you begin to feel crowded*. The research findings were recorded by indicating the location of all figures on a scale drawing of the room. The most pronounced finding was that the lighter rooms contained more figures than the darker rooms—i.e., the lighter rooms appeared larger.

The concept of crowding is one which illustrates the interrelationship of psychological and physical factors. On the one hand, a person may have a feeling of being crowded, but is it the presence of “too many” people in a restricted space which promotes this feeling? As we noted earlier, this feeling might be attributed to the invasion of one’s life space. However, another way of looking at the problem could be from the standpoint of purely physical factors, the requirement for a given volume of space to accommodate man and his activities. The following section of the chapter deals with this issue.



Crowd (Kalett, J., *People and Crowds*. New York: Dover Publications, Inc., 1978.)

<sup>5</sup> A. Baum and G. E. Davis, “Spatial and Social Aspects of Crowding Perception,” *Environment and Behavior*, 8 (December 1976).



## Physical Attributes of People—Anthropometry

The primary task of architects is often said to be the design of spaces to accommodate people and their activities. In this context, building design is the manipulation and arrangement of spaces. Determining the dimensions of these spaces is, therefore, of central importance if buildings are to function as intended.

How does one decide what dimensions are proper?

Le Corbusier made the point that the ultimate measure for buildings must be man. The dimensions of man should, therefore, be the criterion used to specify the appropriate sizes for buildings and their interior spaces. This judgment appears to be a logical one in theory, but Le Corbusier made the assumption that buildings can be successful when designed for the average person. Designs developed from this standpoint assume that man and his activities can be represented by a single set of dimensions.

Is this a tenable assumption?

Rapoport, Watson, and many other researchers make the point that substantial differences are apparent not only among many national and sub-cultural groups but within each of these subdivisions of the world's population. Furthermore, major size variations exist between men and women; adults and children. Finally, the space requirements for handicapped individuals performing activities in buildings are frequently quite different for those for other groups of the population.

Rapoport and Watson<sup>6</sup> also indicate that *all these variations in body size suggest the fallacy of the 'average man' concept. But the influence of anthropometrics on design is made even more complex by the effects of the way man moves and uses equipment.*<sup>6</sup>

**Anthropometry** has been defined as the science of measuring the human body, its parts and functional capacities. Anthropometric studies therefore encompass measurements of the body at rest, as well as the space and other attributes (e.g., shape) necessary for a person to carry out a required task. As was the case for other areas of M/E research, the greatest demand for information was by the military, e.g., for the design



"Man" as a Measure (NBS)

of clothing and equipment. The design of jobs, machines, and equipment to be used in manufacturing and commercial settings also requires anthropometric information. More recently, M/E problems have provided an important impetus to the collection of anthropometric data for building design purposes.

The discipline of anthropometry is traceable to the 19th century work of Sir Francis Galton (British anthropologist), who was the first investigator to conduct extensive studies to determine how physical, sensory, and other characteristics were distributed among the general population (see chap. 19). Galton developed many measurement techniques to acquire the necessary data, and statistical procedures to analyze them, once collected. In all anthropometric studies, statistical considerations are of primary importance. To be accurate, anthropometric measures must be taken on a group of people representative of the population being studied. For example, studies have been made to determine the range of sizes of people who are pilots of military aircraft to ensure that the dimensions of the equipment and the aircraft itself are compatible with the user population. Investigations of this type are conducted using actual pilots and those training to fly airplanes. Much of the research in anthropometrics is conducted by means of surveys of the user population. Since it is often impractical to survey the entire population, statistical procedures are used

to derive from sample studies judgments which may then be extended to the entire user population.

H. Stroud (anthropologist) provides a general survey of anthropometric measurements. These measurement data range from findings about "whole body" characteristics (e.g., size and weight) to data concerning the dimensions of body parts (e.g., face). Both standing and seated positions are employed when structural measures are taken. Other positions are also used when functional data are collected (e.g., prone, kneeling).

As we noted earlier, two types of basic anthropometric measures are employed, static and dynamic. Static measurements are those which are taken with the body at rest. They define the minimum requirements necessary to accommodate the person; for example, while engaging in a sedentary activity such as reading. Static measurements are a major source of data for industrial designers who must specify dimensions of furniture (e.g., chairs) and other furnishings and products used in buildings (e.g., household appliances).

Most activities performed in buildings require movement by people. It is therefore important to know how much room is required to perform a given activity. In developing this information, researchers have identified major causes of movement which are basic to accomplishing a large number of activities. Measurements are then made of people performing these basic movements, and distributions of data compiled accordingly.

<sup>6</sup> Rapoport and Watson



While the study of basic movements required to perform activities is termed anthropometry, the investigation of the actual performance of activities is typically considered to be another discipline; human factors or ergonomics (discussed in the next chapter).

The procedures used to collect anthropometric data range from those employed more than 100 years ago to sophisticated systems designed to simplify the measurement and recording operations required. The tape measure and caliper were and possibly still are the most widely used working tools to collect information. They can be employed to make virtually every required bodily measurement. Reliance on these tools alone makes the task of making many measurements of large groups of people very time-consuming and expensive.

In recent years, alternative approaches have been developed to simplify and quicken the data collection process. One increasingly popular procedure employs a two-way grid system as a means for making rapid measurements. A photometric system is frequently used in conjunction with the grids, as a means of obtaining a record of the dimensions and for determining the dimensions required.

### Pressure Tape

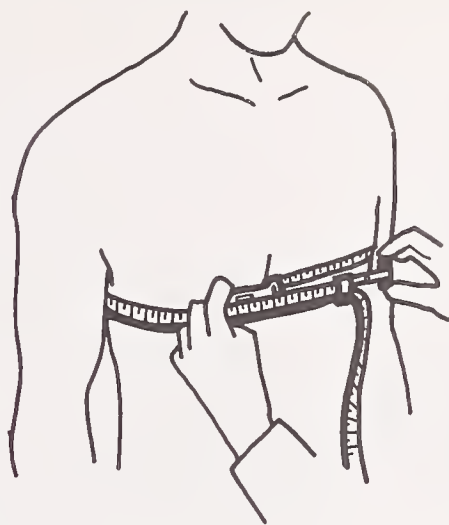

### Anthropometer (shoulder - elbow length)

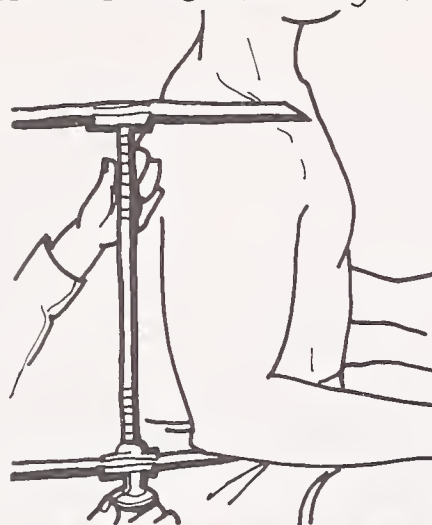

### Sliding Compass (hand breadth)

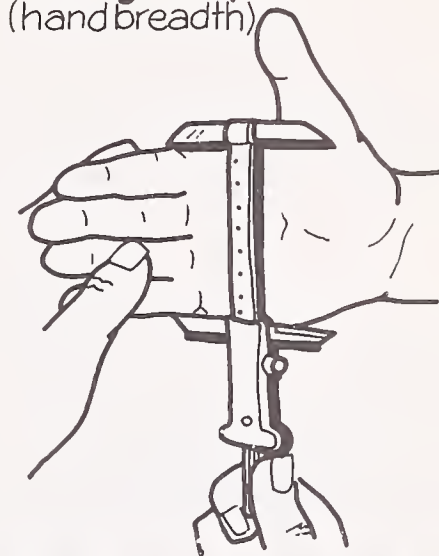

### Photometric System (body measurements)

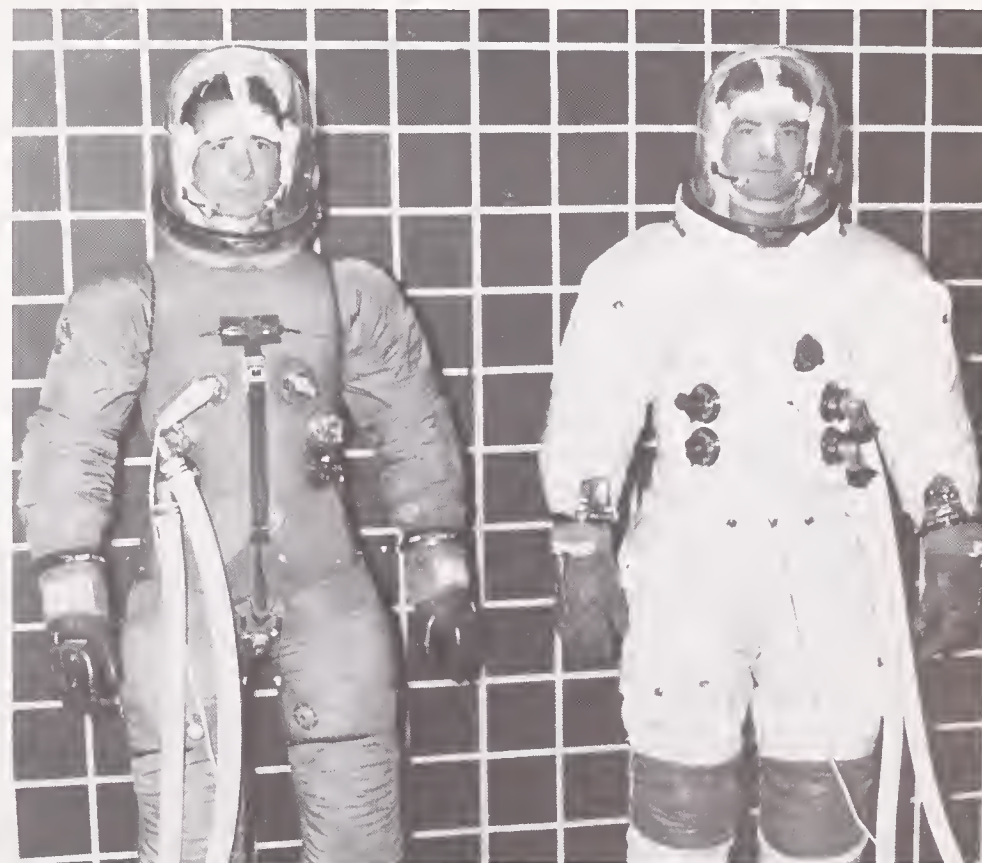

Grid Measurement System as a Part of NASA Program (NASA)

Another procedure employed to determine the dimensions of a reaching task is illustrated in a study by C. Dempsey, who wanted to determine space requirements for Air Force pilots—maximum, minimum, and optimum. In order to obtain this

information, he designed a device consisting of 10 horizontal and 5 vertical arms. When the subject adjusts the sliding arms, the actual vertical and horizontal distance from that point can be measured directly by means of a scale on the side of each arm.

### Outline of Applications of Engineering Anthropometry (Meister)

General Uses and Examples	Anthropometric Data Required	Purpose for Activity
<p><b>Design criteria development and selection</b></p> <p>Determine general and specific population characteristics of users. Measurement of sample subjects, statistical description of sizes, design population selection.</p>	<p>Major body dimensions (height, weight), age, sex, job, color, nation/extraction, geographic areas.</p>	<p>Realistic design and evaluation of dimensional specifications. Customer acceptance, maximize sales, minimize legal liabilities.</p>
<p><b>Design requirements</b></p> <p>Workspace design and development—aircraft cockpits, seats, consoles, tables, etc. Includes any gross volume designed for human occupancy, for work, pleasure, hygiene, rest, treatment, or education.</p>	<p>Reach limits, body clearances, and clothing allowances, forces, torques, centers of mass, moments of inertia, mobility, volume, eye locations.</p>	<p>Assure operator/occupant has adequate volume, proper location of controls, displays, devices, tools. Maximize work efficiency, sales and profits, safety.</p>
<p>Clothing and personal equipment design and development—Emphasis on “engineered” clothing, not on home or business dress.</p>	<p>Circumferences, surface lengths, along body, contours, areas, volumes, diameters, limb movements and restrictions.</p>	<p>Proper fit to the wearer, minimize restriction of movement, define range of sizes and number of each required to prevent overstock. Assure proper workspace interface.</p>
<p>Components and devices—electrical switches: knobs, levers, buttons, etc., handholds, latches, wheels, cranks, stick controls, small appliances, instruments.</p>	<p>Emphasis on the details of body parts in contact with product—fingertips, face contours, foot and shoe shape.</p>	<p>Assure proper interface with hand, foot, head, etc. to enhance operability, safety, convenience, comfort. Maximize sale, reduce rework costs.</p>

### Arm Reach Measurement Device (Dempsey)

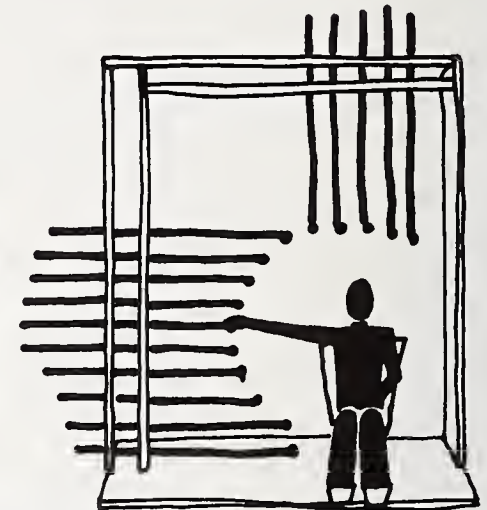



Henry Dreyfuss Associates (industrial design firm) has been one of the leaders in the compilation and application of anthropometric data. Their approach is summarized in *The Measure of Man: Human Factors in Design* which comprises 32 anthropometric charts and 2 life-sized charts, one of the average adult male, "Joe," the other of the average adult female, "Josephine," with anthropometric measurements indicated. A later publication, *Human-scale 1/2/3* includes a series of selector charts which operate something like slide rules and deal with measurements of the body in various positions; measurements for seats and tables; and measurements for the elderly and handicapped.

The first charts were published in 1955. Since then they have been redone several times, with new data added. The charts cover 95% of the adult population. Each chart has three figures—one representing the mean (percentile 50), one representing the small extreme (percentile 2.5) and one representing the large extreme (percentile 97.5).

## Anthropometric Data—Standing Adult Male (Dreyfuss)

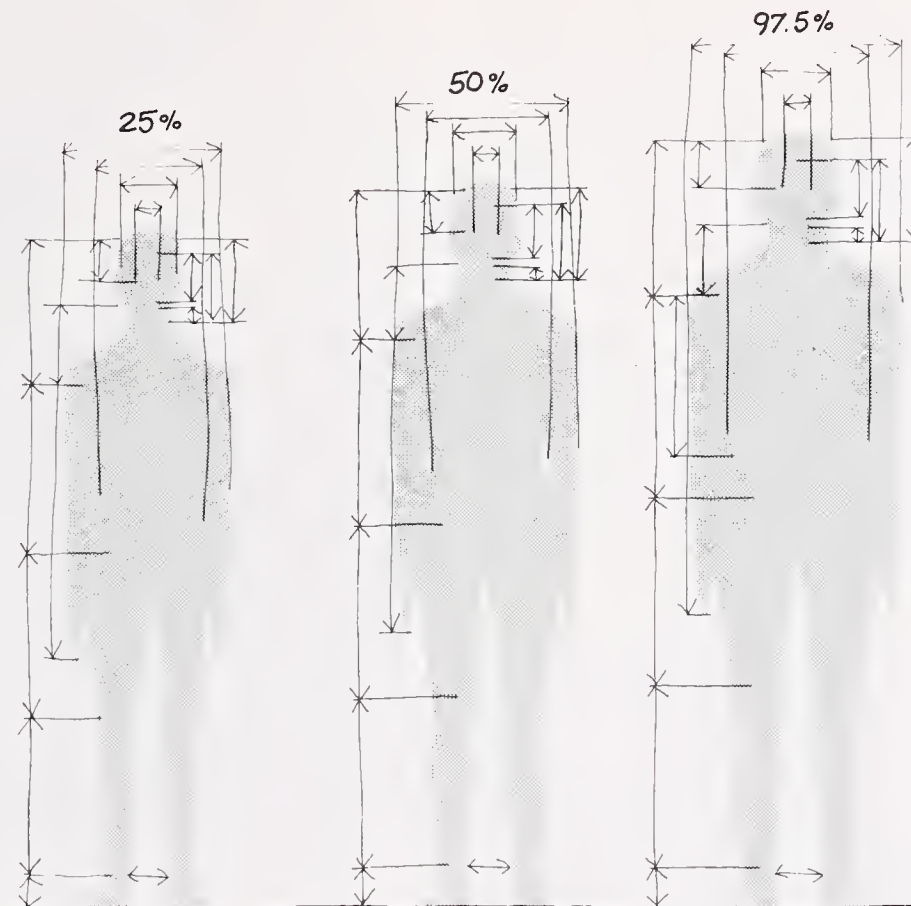

Dreyfuss explains the development of the charts:

*When World War II came, ... the armed forces and their suppliers undertook some very ambitious human engineering and published their findings. But still no one assembled these data into a single package that a designer could refer to.*

*Shortly after the war, our office was working on the interior of a heavy tank for the Army. We had tacked a huge, life-size drawing of the tank driver's compartment on the wall. The driver's figure had been indicated with a thick black pencil line and we had been jotting odds and ends of dimensional data on him as we dug the data out of our files. Surrounded by arcs and rectangles, he looked something like one of the famous dimensional studies of Leonardo. Suddenly, it dawned on us that the drawing on the wall was more than a study of the tank driver's compartment; without being aware of it, we had been putting together a dimensional chart of the average adult American male.*

*We called our average man Joe. We drew Joe standing, sitting, crawling, pedaling a bike. Our charts showed him head-on, in profile, and from above. We drew his wife Josephine and his children just as carefully.<sup>7</sup>*

<sup>7</sup> H. Dreyfuss, *The Measure of Man: Human Factors in Design* (New York, 1967).

## Special Groups—The Aged and Handicapped

Many people in the general population have disabilities which make it difficult, and sometimes impossible, for them to use buildings designed for those without handicaps. The special requirements of this user group have received increased attention lately by all levels of government as well as by the design profession. Possibly the most apparent design response to these needs is the presence of ramps in government buildings to facilitate the movement of people confined to wheelchairs. Many existing restroom facilities are being modified (and new ones designed). These actions taken to accommodate handicapped people in their use of public and private buildings (in contrast to specialized facilities) have addressed problems of one such group. A danger exists

however, that "handicapped" will be defined as those people confined to wheelchairs. Even the symbol used most frequently to depict handicapped people reinforces this idea.

People with visual, hearing and other disabilities should also be considered among those having building user requirements which should receive attention from architects. Some research efforts have been directed toward a better understanding of how well people with impaired abilities (aged and handicapped) are able to carry out their desired activities in buildings. Other studies have focused on overcoming handicaps by substituting alternative means of adjusting to the environment—e.g., substituting one sense for another. We will now briefly describe a number of the research approaches which have been developed to achieve both of the goals just mentioned.



*Negotiating Stairs (E. Steinfeld)*

## Working Dimensions (Grandjean)

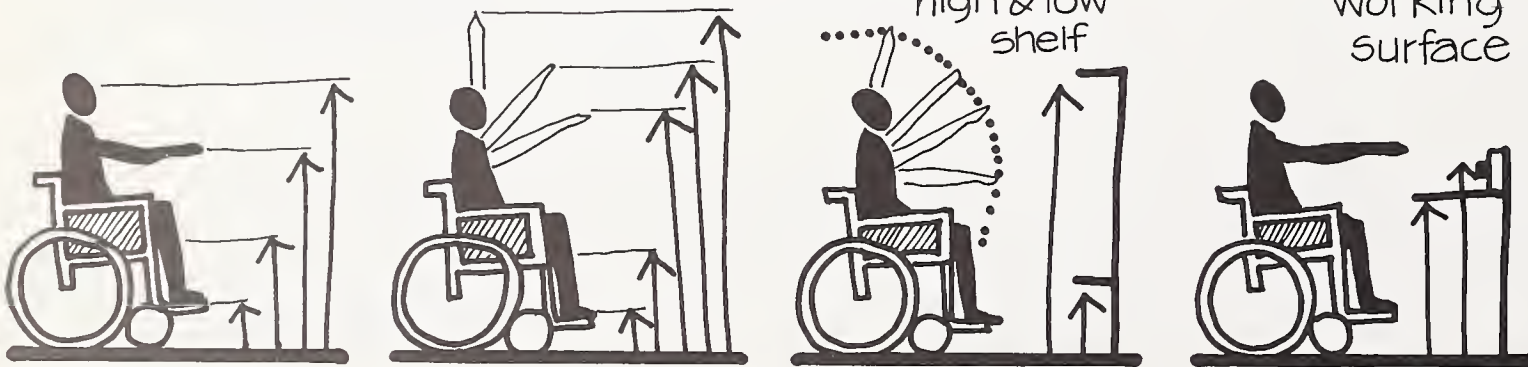



Pastalan sought to duplicate environmental experiences of the elderly by simulating normal sensory loss of a person in his late seventies. Based on age-related sensory loss data, mechanical devices were developed to reproduce the effects of sensory loss. The devices allowed for such simulation in the following sensory areas:

- Visual: The increased opaqueness and decreased elasticity of the eye were simulated by specially coated lenses.
- Auditory: A material in the form of ear-plugs simulated auditory loss above the 2,000 Hz range and decibel loss of around 30.
- Olfactory: Diminished sensitivity to odors was approximated by placing cotton wadding in the nasal passages.
- Tactile: The fingertips were coated with a liquid fixative which simulated a certain degree of touch desensitivity.

A research team of four architectural students under Pastalan at the University of Michigan experienced three specified settings an hour each day for 6 months, in this artificially "aged" condition. The settings were a dwelling unit, a senior center, and a shopping center. Each person kept a daily record of his experiences and from time to time met with the other researchers to compare notes.

In the visual area, glare from uncontrolled natural light and from unbalanced artificial light sources was the greatest problem. A single intense artificial light source increased the likelihood of uncomfortable glare.

Also, colors tended to fade fast, and it was difficult to distinguish the boundary between two contrasting surfaces. With sufficiently similar surfaces, boundaries tended to disappear altogether. Depth perception was affected and adaptation between dark and light areas was difficult as was the ability to discriminate fine visual detail.

In the auditory area, background noise interfered with conversation. Parts of words were often unintelligible, it was difficult to locate and identify sounds, and some combinations of carpeting, acoustical tile and draperies absorbed too much sound and made comprehension difficult.

The simulation of odor loss caused a lessening of appetite. The tactile losses led to difficulty with fine muscle control in eye-hand coordination tasks, and with temperature discrimination.

This work should help architects and designers "see," "hear," and generally experience the world in a way similar to that of an elderly individual. They will then be better able to design to fit the abilities and limitations of the aged.

Space age technology has made it possible for blind people to obtain information in new ways. One development is the conversion of optical images into vibrations. The *optacon* (for optical-to-tactile converter) is one such device, developed at the Stanford University Electronics Laboratories. It consists of an optical camera connected to a vibrating tactile stimulator. An array of 144 phototransistors controls the activation of 144 corresponding vibrating pins which reproduces the visual images. The pins can be sensed by one fingertip. The *optacon* has been employed in reading tasks, with moderate success. Although reading

speed is considerably below that achieved with braille, it has enabled blind people to read conventional printing.

Another system relying on tactile stimulation was developed by Collins and Bach Y Rita. It is termed the Tactile Vision Substitution System (TVSS). The TVSS enables blind observers to "see" objects in the environment using a pair of "seeing eyeglasses" which transmits images to a lightweight camera by way of a flexible fiber-optic bundle. The camera then converts the image into corresponding electronic pulses by an array of small electrodes which are in contact with the skin.



*Handicapped Housewife (HUD)*





*Wheelchair Operated by Microphone (NASA)*

## Effects of Past Experience

One characteristic of people frequently important in M/E studies is past experience.

Individual, social, and cultural factors result from experiences which the individual brings to any new setting. These are likely to be used as a framework (set of criteria) for judgments that are made about current environments because they lead to expectations based on past experience. For example, assume that three families are to move into public housing. Each family differs considerably from one another with respect to the quality of their previous homes (the home of one family was far better than the public housing, the home of another was equivalent, and the third home was of lower quality). Under these circumstances, if the homes were being evaluated by the occupants, the ratings might well reflect the differences between the previous home and the present one rather than merely an absolute rating of the present one. Data limited to *present* living conditions therefore could be confusing and misleading.

Naturally, the main interest of the designer should be the future success of a building, not the past history of building occupants. Yet, the present acceptance of a building might be closely related to the past history and expectations of occupants. The same type of reasoning leads us to conclude that future building users should not be ignored in the design process. Changes in values, technology, life styles, and conditions in society are all likely to affect building usage. Moreover, these changes are likely to have an impact even when the same people occupy the same buildings. These factors all should lead us to expect a greater degree of success for buildings which enable occupants to modify their environments to meet changing needs.

## Conclusion

We have discussed several aspects of special user populations and highlighted the many differences which exist among potential user groups. Our concern was to emphasize the need to consider the requirements of special populations in the development of a design program. In the next chapter we will consider research approaches employed to observe and measure how activities are performed in buildings. The research methods to be examined are primarily derived from human factors (ergonomic) studies dealing with how people interact with objects, machines, and complex systems.



# 8

## Man/Environment Interactions

- Origins—Industrial Studies
- Body Position and Performance
- Displays and Controls
- An Integrated Approach
- Occupant Fire Safety
- Accidents in Buildings
- Movement of People in Buildings
- Conclusion

*Catherine Beecher ... published a series of house designs in her book of 1869 . . . her floor plans reflect quite accurately the new relationship of family to society, house to urban environment. Two qualities stamp them as essentially modern: the way in which all her enclosed volumes are designed to facilitate specific housekeeping tasks; and the masterly way in which she exploits the new urban services and absorbs them into the very fabric of her plans.*

*Her houses are firmly visualized as machines for family life. No longer are there generalized or anonymous spaces: from top to bottom, each area has been carefully organized to serve a specific function.*

*Here, in short, is the prototype of that urbanized house. For all its graceless and inept details, it is the direct progenitor of the modern American house.<sup>1</sup>*

**Kitchen Work Center - 19th Century**  
(Beecher)

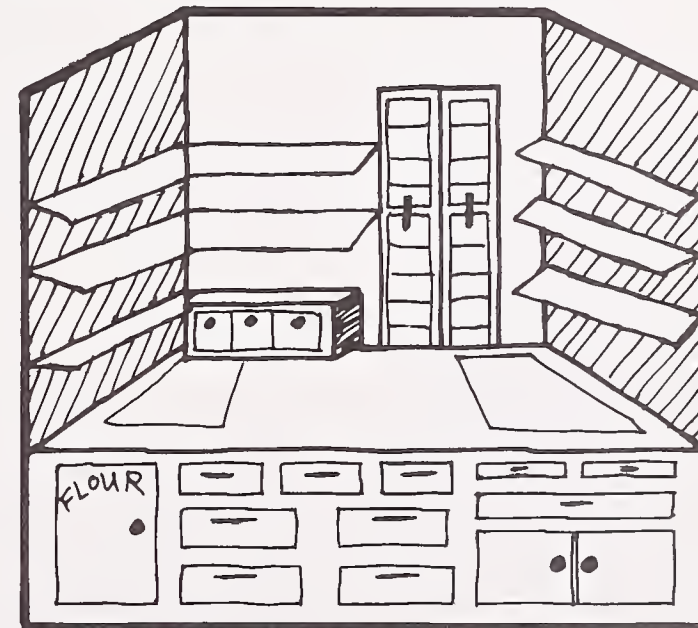

<sup>1</sup> J. M. Fitch, *The Architectural Manipulation of Space, Time and Gravity* (New York, 1969).

We said earlier that M/E problems should be examined from a systems viewpoint, and that activities are a major focal point of our interest. The performance of activities is influenced by the interaction of many behavioral and design factors. While a start has been made by human factors researchers who have dealt with some M/E problems, M/E researchers face a formidable challenge in their attempts to better understand the nature of these relationships.

Human factors, like architecture, includes problem areas ranging from the "macro" to the "micro" scale. At the macro scale, the concern is how human performance relates to an overall system. For example, a problem faced by both equipment and building designers is the need to integrate manually operated controls for best system performance. For example, effective lighting depends upon the ability to control the quantity and quality of light where it is needed—e.g., to perform a task. A further desirable characteristic, in view of the concern for energy conservation, is to have lighting in areas only where it is required. Consequently, area control of lighting is more desirable than a single control for a partially occupied large area. The architect must then determine where to place light switches (or other controls) for maximum effectiveness.

At the micro scale, a major concern is the proper design of products (e.g., machines, furniture). This interest is synonymous with that of the industrial designer. Between the macro and

micro scales, researchers have addressed problems of permanent and temporary features of buildings, such as determining the proper dimensions for shelves and kitchen work surfaces. The common feature in such investigations is the focus on performing a given activity.

C. Dempsey's study (chap. 7) illustrates one approach to collecting basic anthropometric information for the design of a work place. The research addressed the need to make controls readily accessible to operators. The problem was attacked by determining the maximum feasible reaching distance (and direction) for controls used by an operator seated at a work station. The design of tasks (or activities) involving people and machines, objects and environmental features such as stairs, makes up the discipline of human factors, also known as ergonomics. It may be defined as *the adaptation of human tasks and working environments to the sensory, perceptual, mental, physical, and other attributes of human beings.*

### Origins—Industrial Studies

F. Taylor (machinist and plant supervisor) is often termed the father of scientific management. He formulated the idea of conducting analytic studies which were designed to increase the productivity of workers. His approach was to standardize work procedures, based on the way that the best workers performed their jobs. The work activities and rest pauses were specified completely, with the worker treated virtually as a machine.

Time and motion studies were used in the 1920's by F. Gilbreth and his wife, L. Gilbreth (engineers) to break down jobs into their elementary operations. The basic concept was that work productivity differed greatly from person to person because of individual differences in skills. Differences in work methods may be best analyzed by slow motion photography, both for finding the errors of less skilled workers and for teaching to new employees the superior methods of the most highly skilled workers. There are general principles and procedures that may be applied to all jobs. At first, they employed a stopwatch and described the nature of the motions used. Later, they recorded minute movement using photographic procedures. Movements were charted into 16 elements of motion, said to be the basic elements of industrial processes.

### Task Coding Scheme (Gilbreths)

#### Symbol/Task

#	Disassemble
0	Inspect
△	Pre-position
⊙	Release Load
∪	Transport Empty
∩	Unavoidable Delay
⌒	Avoidable Delay
⊠	Plan
⊖	Search
⊙	Find
→	Select
∥	Grasp
∩	Transport Loaded
9	Position
#	Assemble
U	Use

### Time and Motion Study (Taylor)





The general approach developed by the Gilbreths was later used by human factors researchers to analyze activities. The procedure is called task analysis. It is used to identify the factors necessary to adequately complete a task. The goal is to define the critical activities occurring in a work situation in such a way as to provide a sound basis for performance evaluation. Another purpose is to aid in modifying job operations in order to facilitate performance and avoid error.

During the planning phase of task research, an analysis of the problem is usually undertaken to identify the critical elements which are to be studied and measured. R. Miller (psychologist) developed a general technique used to determine the psychological factors essential to the adequate performance of a task. This model can be just as readily used to examine the activities performed by a family at dinner. The goal set out by Miller is to define the critical activities in a situation to provide a basis for evaluating performance.

### Task Analysis Procedure (Food Preparation) (Miller)

Activity	Requirement (example)
1. Enumerate tasks	Prepare food, set table, serve food, clean up after meal
2. Identify critical information in tasks	"Hardware" needs—stove, oven, table—special difficulties—analysis of functions (psychological factors)
3. Identify rate or time needs	Cooking times, temperatures used
4. Chart tasks on time base; show time sharing	Sequence of activities, overlaps, cooking, washing dishes, serving

### "Psychological" Factors in Food Preparation (Miller)

Factor	Requirement
Perceptions and discriminations	Determining when food is ready to be served
Decision making and problem solving	Determining the dinner menu, seating arrangements
Recall of stored information	Purchasing needed supplies, proper preparation of food
Motor responses	Grating, cutting, stirring, basting, serving
Monitoring	Watching food while cooking
Communicating	Requesting advice, information

### Body Position and Performance

A major concern for those responsible for designing a work area is the typical position of the body when an activity is being performed (e.g., seated, standing). Methods have been employed to investigate the relationship of body position and task performance. We will first consider studies where people are required to stand when using shelves and work surfaces in the kitchen.

A Swedish report (*Anatomy for Planners*) discusses various experimental procedures used to correlate body measurements and height of reach, working heights, and space measurements.

Four techniques were used to measure reach height. The first involved the use of a **pedometer**, which involved the placement of contact plates on the hands of the experimental subject. These plates recorded the change in the distribution of body weight. The subject's task was to place both hands with the palms down on a shelf of adjustable height.

The second technique involved the use of **electromyography (EMG)** which measured the degree of activity in a muscle, and this in turn indicated the extent of the load on that muscle. In the case of reach height, EMG was used to measure the distribution of load on the subject's leg muscles.

In the third test, researchers asked subjects to indicate what they felt would be the most comfortable reach height. Finally, the experimenters employed **stereophotography**. This enabled them to photograph movement simultaneously from side, front and rear. From these photographs it was possible to determine which joints a person used when stretching to reach high shelves and also indicated the sequence in which the joints were active.

The results from these four measurement techniques were used to develop the following criteria set up by the experimenters:

*When the person tested lays the entire palm of a hand on the shelf, his or her weight should be borne equally by both feet, as it is when one stands upright in a symmetrical and relaxed posture; the person tested must not lean against the worktop; distribution of weight on the leg muscles must be the same as when a person stands in a symmetrical and relaxed posture; the person tested should feel that he or she reaches the shelf height being tested. The shelf height at which all these conditions are fulfilled was designated "vertical reach."<sup>2</sup>*

Now that the height of the shelf had been determined, the researchers developed a task to determine the maximum size for practical shelf design. The following objects were placed 1 cm from the edge of the shelf: a cube and a cylinder each weighing 1 kg, a book, a plate, a drinking glass, and a teapot. The ob-

jects were gradually moved inward until the subject could no longer reach them. The experimenters recorded the distance from the edge of the shelf to the depth of the subject's maximum reach.

Working heights (such as height of sink or kitchen work surface) were measured by having the test subject indicate the height that was the most comfortable for him and by having the experimenters observe the subject's posture at various heights.

For all dimensions required to make space measurements (such as using a built-in oven or low cupboard), a screen technique was used. An easily movable screen was placed behind the subject. The subject moved the screen the necessary amount when he bent down to use the oven or low cupboard. For space measurements which also required movement in front of the subject, two screens were used.

### Screen Technique (Swedish Researchers)

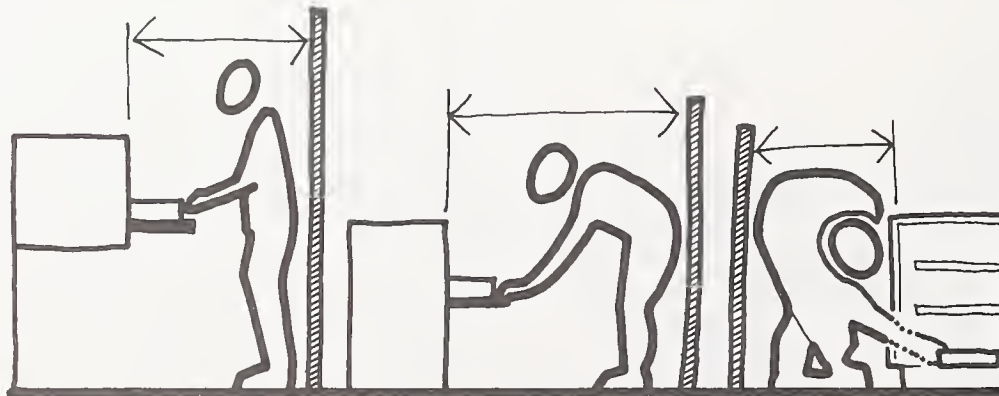

### Recommended Table Heights for Standing Work (Ward and Kirk)

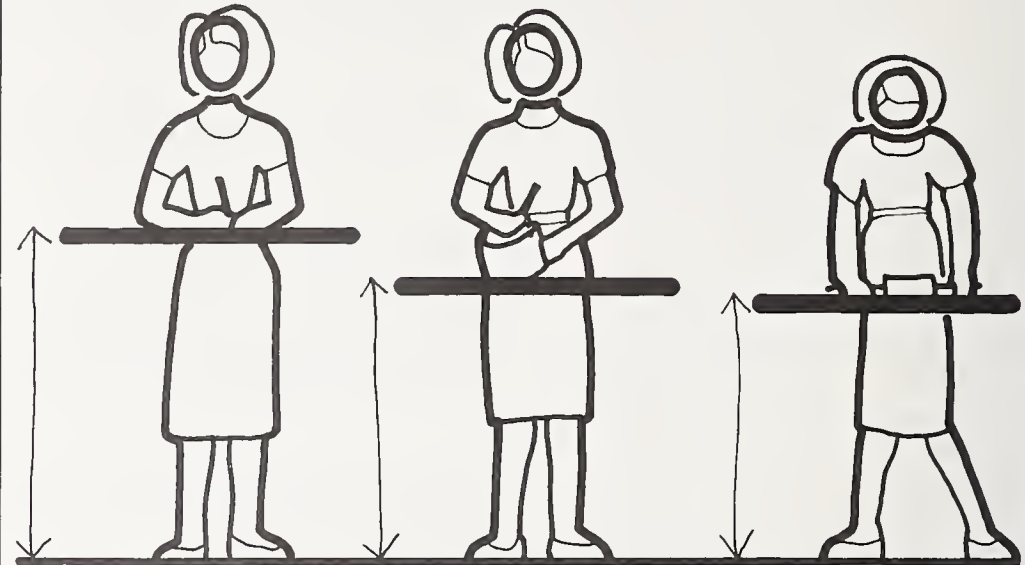

**Delicate Work**  
100-110 cm (men)  
95-105 cm (wm.)

**Light Manual**  
90-95 cm. (men)  
85-90 cm. (wm.)

**Heavy Manual**  
75-90 cm. (men)  
70-85 cm. (wm.)

Other researchers have been interested in the relationship between anthropometric findings and data obtained from subjects who were permitted to regulate the heights of the working surfaces on which they performed their tasks.

J. Ward and M. Kirk (psychologists) permitted subjects to work on a given task at a working surface height judged to be most comfortable. Each task was performed in two ways, seated and standing. Correlations were then calculated between the anthropometric and preference data findings.

<sup>2</sup> *Anatomy for Planners* (Sweden, 1970).



Chair design has received considerable research attention. E. Grandjean (Swiss researcher) and U. Burandt developed a sitting machine to study seating comfort. The machine allowed a great deal of variation in the shape of the seat and back rest, the height of the seat, and of the armrests. Instruments in the chair recorded body movements and the variations these movements produced in the pressures of the body on the seat and back rest. A questionnaire asked for an assessment of seven body postures as "uncomfortable," "indifferent," or "comfortable." Then questions asked for an assessment of individual components such as seat depth. The results indicated that the latter questioning provided a better assessment of seat comfort.

### Design for Experimental Chair (Grandjean)

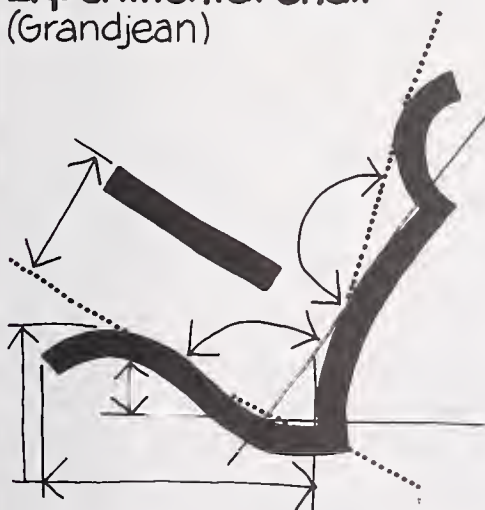

N. Diffrient (industrial designer) applied the techniques used to develop the *Measures of Man* (see chap. 7) to the design of aircraft seats. Physiological data on seating posture were collected by x-rays. An extremely flexible sitting-machine was developed allowing research subjects to change seat bottom and back cushions and also allowing for adjustment of recline angles, armrest positions and seat heights. A system was devised in which small probes were placed in the seat cushions and when the cushion was depressed the probes protruded a distance comparable to the depression. A grid diagram of the body's interaction with the cushion was obtained.

In another study, R. Wachsler (psychologist) and D. Learner used the following criteria to assess the comfort of different chairs:

- The length of time a person occupied a particular chair.
- A questionnaire asking the individual to rate the chair on a scale running from -4 to +4 after sitting for three different durations.
- The time at which a sensation of discomfort occurred.
- The location of discomfort in the neck, shoulders, back, buttocks, or legs.

The researchers found that the most reliable measure was the occurrence of discomfort in the back and buttocks and how soon after occupying the seat the discomfort occurred.

The methods employed to develop user information for designing objects, as with M/E research generally, depend on varying levels of involvement by potential or simulated users. At times designers have relied on statistical data (e.g., anthropometric measures) for determining the dimensions of objects. In other instances, formal investigations were conducted, in which the design information collected was largely based upon the behavior of research subjects. The latter type of study was performed by Le Carpentier (French ergonomic researcher).

The determination of desirable chair characteristics for leisure activities was the object of Le Carpentier's study. Twenty subjects, 10 male and 10 female, participated in a study which required them to read or watch television for several 3-hour sessions. Each subject could adjust the characteristics of the chair as desired (in terms of angles and dimensions) by means of manual controls. The results indicated that while male subjects preferred chair settings which permitted their legs to be outstretched, female subjects were more apt to keep their legs in a vertical position.

### Preferred Armchair Dimensions and Adjustments Based on Activities of Reading, Television Viewing (Le Carpentier)

Construction detail	n (Subjects)	Standard Deviation	Recommendation		
			Average	for two positions	
				only one position	
Front height of seat, unloaded (cm)	20	40 ± 3.8	38	38	42
Depth of seat (cm)	20	48 ± 3.2	47	47	47
Angle of seat (°)	20	10.3 ± 3.4	10.5	9	12
Angle between seat and backrest (°)	20	109.1 ± 5.5	110	113	105
Armrests, height above seat when occupied (cm)	12	16 ± 1.6	16.5	16.5	16.5
Head rest in front of back surface	12	3.8 ± 5.7	6.4	6.4	6.4
Angle between headrest and backrest (°)	12	7.9 ± 3.3	8	8	8

## Displays and Controls

Many work and other activities require people to obtain information from their environment. Depending on the nature of the information obtained, they select a course of action from several alternatives. In human factors research, the device used to convey information is termed a *display*. The most commonly used displays depend on visual and/or auditory signals. Such displays are commonly employed in cooking tasks: a light which identifies the stove burner which is on; a buzzer which is preset on an oven to indicate that the required baking time has elapsed.

While a display indicates that an action should be taken, *controls* serve the purpose of enabling the person to take action. Control design has been of major human factors interest because of the variety of movements and forces that can be applied by users. Speed and accuracy data have been collected on tracking tasks (gunnery, radar) where the motion of the operator is continuous.

Anthropometric measures of arm, leg, and back strength have been compiled in the design of levers, and automobile emergency brakes, as well as foot brakes. Other measures which have been made include grip, elbow, and shoulder strength. Relationships between direction of motion and strength, while seated, standing and lying down, have also been systematically compiled.

A systems approach is employed in the design of a configuration of controls and displays. There are several possible principles of arrangement. In a functional arrangement, the grouping is in accordance with the activity being performed. (In an aircraft, all of the flight instruments can be placed together.) Another grouping might be on the basis of importance, where critical displays and controls would be placed in the most easily accessible positions. The best location is another possibility with "best" depending on convenience, accuracy, speed, or strength. A sequence-of-use method is based on patterns of normal operation (items physically positioned in accordance with sequence of use). Finally, a frequency-of-use principle can be used.

The determination of the proper relationship between manual controls and displays has received considerable attention. The activity is one of simultaneous monitoring and control. An operator is typically required to monitor several displays and make control adjustments as the circumstances demand. Jobs of this type, which were formerly associated with military, space, and aircraft operations, are now often found in high-rise buildings with centralized communications, fire and surveillance systems. Moreover, the problem is one which is constantly addressed by those designing appliances and other apparatus used in buildings.

An illustration of a procedure often employed is presented by A. Chapanis (human factors researcher) and L. Lindenbaum who examined four different control/burner configurations for a four-burner stove. Fifteen subjects took part in a study where they were instructed as to which burner should be turned on. Each subject performed this task for 80 trials, using each control/burner configuration. The results of the study were evaluated in terms of the total errors which occurred for each design, and the time taken to respond (the time measure was only for the last 40 trials for each condition). The two measures were consistent with one another in that they both pointed to the same control/burner arrangement as being the preferred one. Thus, an appropriate design was found.

### Control-Burner Arrangements of Simulated Stove, Errors in 1200 Trials (Chapanis and Lindenbaum)

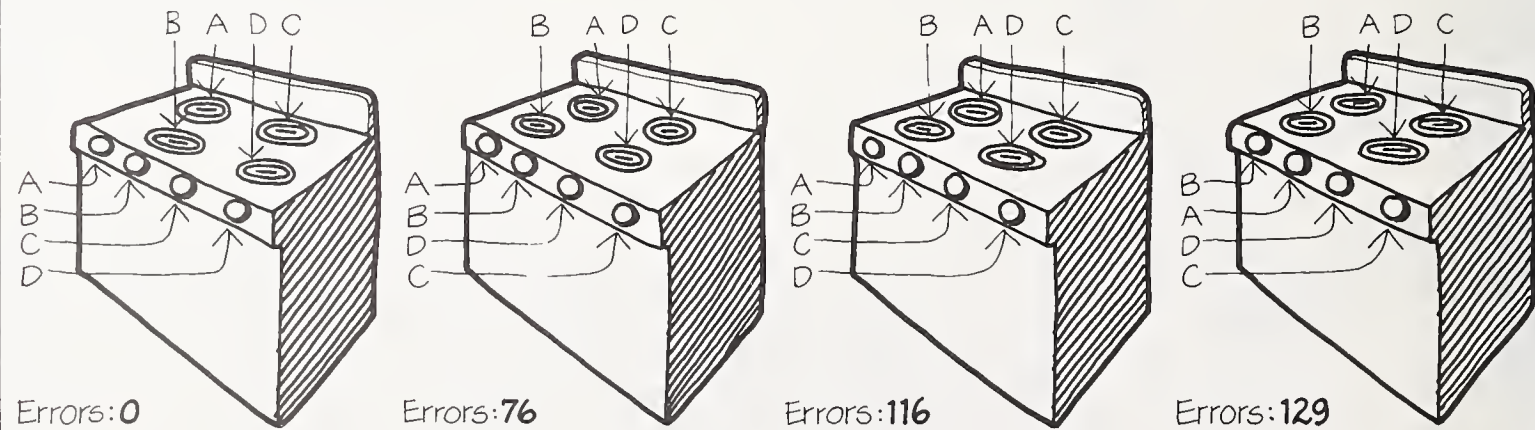



In a different type of human factors study, J. Sheridan (psychologist) and other researchers at the Bell Telephone System were faced with the problem of integrating women into some of the jobs requiring basic construction-type work. The researchers felt that the women might have difficulty handling the heavy equipment since:

*For example, women aren't as tall as men, women have shorter legs and arms with longer torsos, women have a larger proportion of flesh mass that is not muscle and, consequently, are not able to do work as men do, there is a difference in vital capacity that results in endurance differences between the sexes and so on.<sup>3</sup>*

### Aircraft Panel

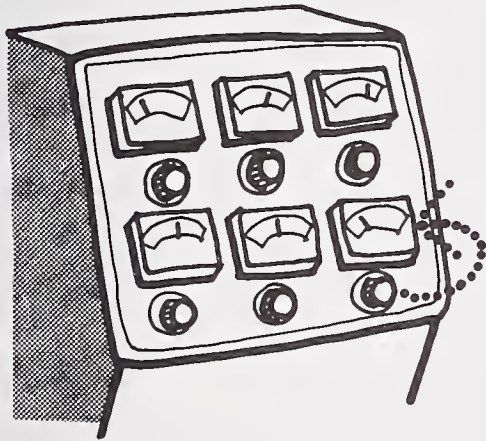

### Kitchen Stove

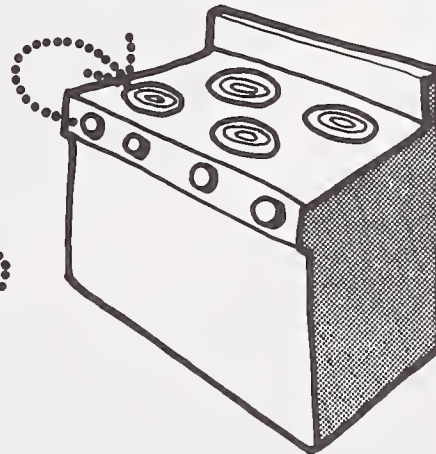

Research dealing with one problem is often helpful in solving similar problems (eg., display/control relationships)

<sup>3</sup> J. A. Sheridan, "Designing the Work Environment," in *Proceedings of the Symposium on Environmental Effects on Behavior*, ed. W. D. Bliss (Bozeman, Montana, 1975).

The researchers took one piece of equipment, the ladder, and observed women trainees as they performed or attempted to perform the four basic functions involved in handling ladders: (1) Getting a ladder on and off a truck, (2) Carrying the ladder to the work site, (3) Raising the ladder, that is, standing it against a building in the unextended position, and (4) Extending the top or fly section of the ladder.

All of these tasks require specific physical skills involving strength and balance, many of which are difficult for women. However, by the application of some simple mechanical concepts such as fulcrums, levers and pulleys, many of the difficulties were overcome.

## Modifications of Equipment (Sheridan)

Lifting force required is about **40 lbs.**

Ladder pivots about one end

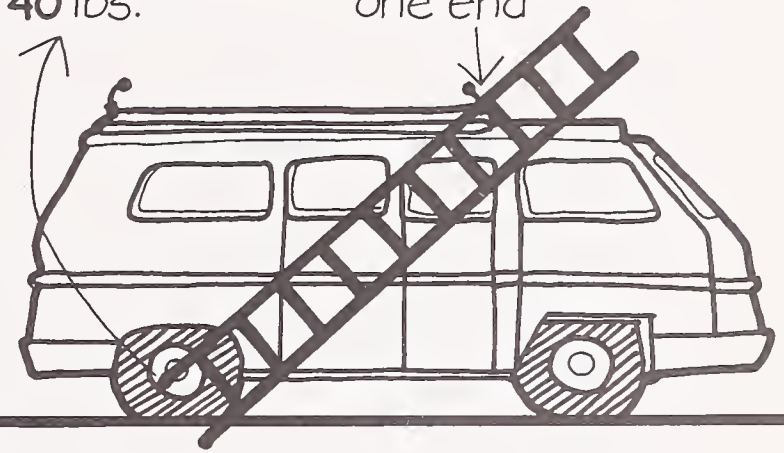

Pivot point moved to midpoint of roof rack:

Lifting force is now as low as **10 lbs.**

Ladder pivots close to midpoint

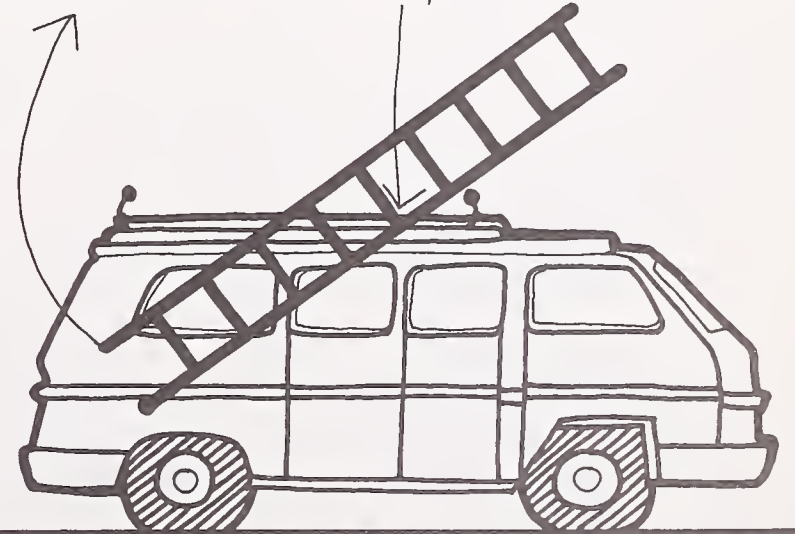



## An Integrated Approach

A. Kira (architect) integrated research from physiology, human factors, and anthropometry. He studied bathrooms so he could make design recommendations for the more logical and functional design of these facilities.

Kira's study included a literature search, a field survey, and a laboratory investigation. The literature search concentrated on material in the areas of anatomy, physiology, sociology and anthropometry. A survey was conducted with 1,000 middle-class households on personal hygiene attitudes and practices. The laboratory research concentrated on the functional, physiological, and dimensional aspects of hygiene activities. Films were taken of individuals engaged in a variety of activities and crude working models were made.

Kira's investigations covered the areas of physiology, anatomy, anthropometry, comfort, safety, acoustics, lighting, ventilation, odor, thermal environment, aesthetics, materials, sociology, and psychology. Kira stresses that although it is necessary to design each element carefully, *the important point is that a total facility is conceived of, and provided in the form of, a fully integrated package.*<sup>4</sup>

<sup>4</sup> A. Kira, *The Bathroom: Criteria for Design* (Ithaca, N.Y., 1966).

Kira also emphasizes the fact that anthropometric and other objective measures cannot be applied outside their context. He expressed this limitation as follows:

*Although this study has attempted to be scrupulously objective, on the one hand, in its explorations of physiological processes, anatomy, anthropometry, etc., it has on the other, been deliberately conceived within the framework of contemporary Western culture. Consequently, the discussion which follows represents, to a certain extent, a compromise between realities as they exist and as they are defined with our time place setting. Some of the personal hygiene practices of other places or times could seriously be recommended as being more desirable from the standpoint of either health or physiology—if our values, ideals, and way of life reflected the same cultural attitudes as those under which the practices evolved. As the discussion will show, however, there are almost as many psychological and cultural problems to be solved in developing design criteria as there are purely physiological or functional ones, and in some instances, it may also be said that the problems to be solved are the psychological and cultural ones.*<sup>5</sup>

<sup>5</sup> Kira

## Occupant Fire Safety

A. Rubin (psychologist) and A. Cohen (operations researcher) were concerned with occupant fire safety. They employed a human factors approach to better understand occupant behavior in building fires. A look at the informational requirements of occupants in fire emergencies (as opposed to ensuring a degree of structural integrity for the building) found present information to be inadequate. The increasing number of high-rise buildings with many occupants inten-

sifies the need for better information about the behavior of occupants during fire emergencies. Fire researchers say it is often not feasible to evacuate buildings due to lack of time. Instead, designers use techniques such as employing safe areas within buildings. This approach emphasizes the importance of communications and warning systems to transmit messages. These systems, such as loud noises or blinking lights, should be designed to "take advantage" of the usual responses made by people.



*Building Fire (NFPA)*



The design concern is to identify building design features (e.g., clearly marked safety routes) which can be used to help people reach safety. Before proposing design solutions, questions must be posed in a manner which can provide answers in a useful form. For example:

- What features of the environment either help or hinder the ability to leave the building?
- How much illumination is required to safely descend the stairs during a fire?
- What information is needed before a fire alarm is regarded as real rather than a test?
- What is likely to catch the attention of most people and therefore might be used for an alarm signal?

- What exit markings are appropriate?
- How does the presence of smoke affect the ability to respond to visual and/or auditory alarm signals?
- How do individuals' needs differ in fire emergency situations—aged, handicapped, children?

An inspection of the subject matter covered by these questions gives a hint of the range of informational requirements needed. To obtain the answers, research must span both fundamental and applied problems. The basic data requirements will include information concerning the functioning of the sensory processes of vision and audition during emergencies.

Another misunderstood area is what constitutes "normal" behavior in an emergency. If we knew *how* an individual typically responds in an emergency and *what* is responded to, the design of safety systems could be much easier. (This statement assumes that most people would respond in a common way, and even for those who are not typical, the newly designed safety systems would be no worse than those now in use.) The applied research calls for a better understanding of the situation requirements typical in fire emergencies, including the social forces that operate on an occupant. It is extremely important to identify the tasks that an occupant *can* perform and to determine how he can best function as an integral component in the design of a complex fire safety system.

A method for graphically depicting activities which occur during building fires has been developed by L. Lerup (architect). He employed a map to indicate the locations and activities of building occupants during a fire. The map indicates the location and progression of the fire, and along with this, shows the behavior of the occupants by means of *decision points* (DP) and behavioral *episodes* (E). Several categories of occupants are mapped: e.g., patients, staff, fire fighters, and affected outsiders such as neighbors. Letters are used to locate each individual: "a" indicates the individual's location in the immediate past, "b" indicates his location in the future and "c" indicates the route he has taken to get from a to b. Further clarification may be given by "d," a cartoon which may be accompanied by a written caption and serves to clarify the occupants' behavior in greater detail. The cartoons give a clear image of the occupants' interaction with the setting.

## The Case Study Format to Describe Fire Emergency Behavior

(Lerup)

1:15

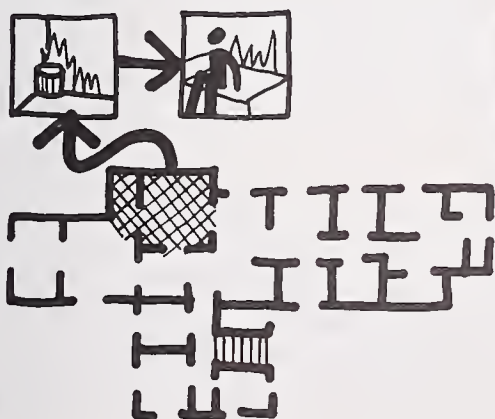

1:20

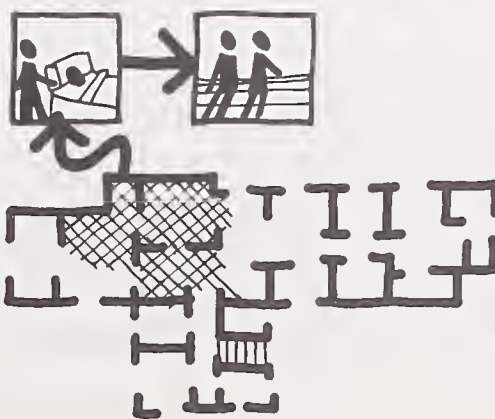

1:25

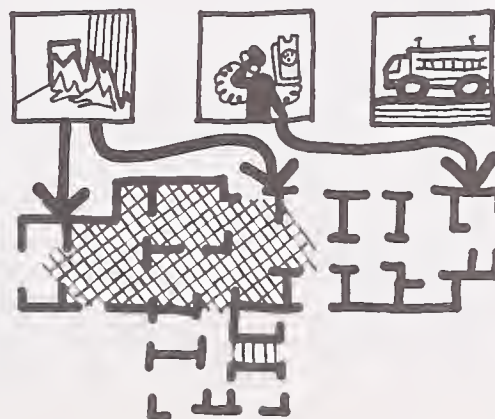

1:30

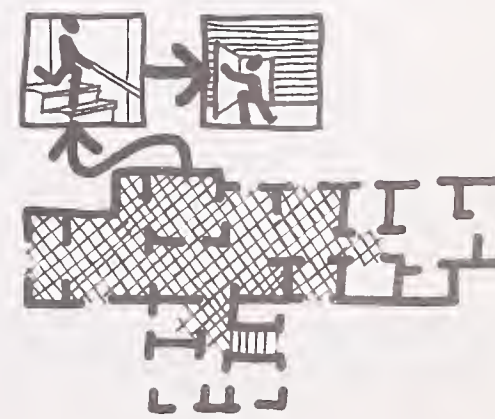



Prior to the development of graphic mapping, researchers had studied fires almost exclusively by looking at the physical characteristics of a building. Lerup hopes that his technique will allow the study of the interaction between occupant behavior and the physical setting during a fire emergency.

The Division of Building Research (DBR) in Ottawa, Canada has pioneered the documenting of actual movements of large numbers of people in high-rise buildings and other structures containing large populations. J. Pauls (Canadian architect) has been a leader in these activities since 1968, developing an impressive set of empirical findings based on evacuation drills.

His first study was in the 22-story Hydro building in Vancouver, British Columbia. In describing the background for this study, Pauls noted the intensified interest in emergency evacuation as a result of fire incidents in tall buildings. As part of a total approach to life safety in buildings a need existed, he said, for information describing the context, procedure, and efficacy of building evacuation. He continues:

*During the first two minutes of the drill, a prearranged procedure was followed to check the source of the alarm and organize key evacuation personnel. When total evacuation was ordered over the building's public address system, floor wardens supervised the clearing and checking of each floor before reporting to a central control center, using an emergency telephone system. It*

*took twelve minutes to clear the building once the evacuation was announced. Of a total of 945 people from floors above the mezzanine level, 910 left by two 47-in. exit stairways and 35 used a supervised elevator.*

*They (the exit stairways) have a width of 47 in. at shoulder height, and each stairway has an area of 155 sq. ft. per story, of which about 140 sq. ft. is the effective area taken up by a 47-in.-wide stream of people. The length of the travel path per floor is 40 ft. measured along the centerline of a 47-in. path down the stairs and landings.*

*Evacuation procedures for the B. C. Hydro Head Office building are designed to be simple to follow while permitting flexible control by key evacuation personnel. Total evacuation, for example, is initiated by means of a siren signal and an announcement, both transmitted over the building's public address system. (The building is not equipped with a general fire gong system.) Evacuation of each floor occurs under the direction of a floor warden or his alternate; people line up in the corridor area at the designated exit and proceed down the exit stairway as the warden directs.<sup>6</sup>*



People Exiting High-Rise Building (NBS)

As for communications, Pauls quotes evacuation personnel and observers after the drill as saying that with a few exceptions, the siren and the initial announcement, both transmitted over the public address system, were clearly heard everywhere on the floor areas. With no speakers in the exit stairways, however, there was reportedly some confusion when some of the wardens stationed at the emergency telephones failed to hear subsequent announcements. In terms of their initial interpretation of the public address announcements, Pauls said that all the evacuation personnel, and presumably most of the other occupants, were sure it was an exercise not a real emergency.

Between 1970 and 1972, nearly 40 test evacuations involving about 20,000 evacuees were observed by Pauls and his associates in office buildings ranging from 8 to 29 stories. The chief goal of these observations was to collect data describing the nature of evacuation movement, any influences on such movement, and other relevant behavior of individuals and groups, including supervisors. Large-scale data collection was often necessary because of numerous variables that could not be controlled experimentally.

<sup>6</sup> J. L. Pauls, "Movement of People in Building Evacuations," in *Human Response to Tall Buildings*, ed. D. J. Conway (Stroudsburg, 1977).



Observation techniques included equipping 2 to 15 observers with portable cassette recorders to register all observations and background sounds. These observations, tape recordings of any communications used in the evacuations, and visual records provided by slide photography and video tape recording, could all be played back realistically. In effect, the evacuation could be re-run for purposes of detailed analysis. For example, in one 21-story office building nearly 20 channels of audio recordings were made at both fixed and moving observation positions throughout the 30-minute period of a phased total evacuation exercise involving over 2,000 people. Observers moving with evacuees from floor areas to the outside of the building were able to record data for a wide range of behavioral variables, often without the knowledge of evacuees only a few feet away.

In terms of method and quantity of data, these observations appear to have no research precedent.

### Factors Contributing to Accidents (Suchman)

#### Predisposing Characteristics

Susceptible host  
Hazardous environment  
Injury producing agent

#### Accident Conditions

Unexpected  
Unavoidable  
Unintentional

#### Situational Characteristics

Risk-taking  
Appraisal of hazard  
Margin of error

#### Accident Effects

Injury  
Damage

## Accidents In Buildings

While fire emergencies are a threat to people in buildings, they are rare and not experienced by most people. On the other hand, most people suffer accidents in buildings during their lives.

Berns et al. studied causes of home accidents involving children. Two studies were conducted. In the first, families were asked to keep a record for 23 days noting all occasions on which accidents or near accidents occurred. Follow-up interviews were conducted with the families concerning reported accidents. The researchers discovered some problems with this method as it was hard to get individuals with young children to take the necessary time to complete a diary. The second study used a detailed questionnaire to determine important risks; it also included studies at the accident scene. The following items were found to be the most frequent cause of accidents: playground equipment, doors, furniture, bicycles, stairs, and cookers.

One procedure developed to better understand why accidents occur is the concept of *critical incidents*, formulated by J. Flanagan (psychologist). The procedure identifies job requirements which are judged to be critical by participants or supervisors. A critical requirement is one which "makes the difference" between the successful performance of an activity and the failure to complete it. Flanagan used the study of "near accidents" as a means of reducing accidents. He conducted a study for the Air Force based on official accident reports. Accidents were categorized in terms of mechanical failures and human errors. His findings indicated that most of the cases cited were due to human error, e.g., incorrect altimeter readings, leading to aircraft crashes.

## Reading Altitude from Different Instruments (Flanagan)

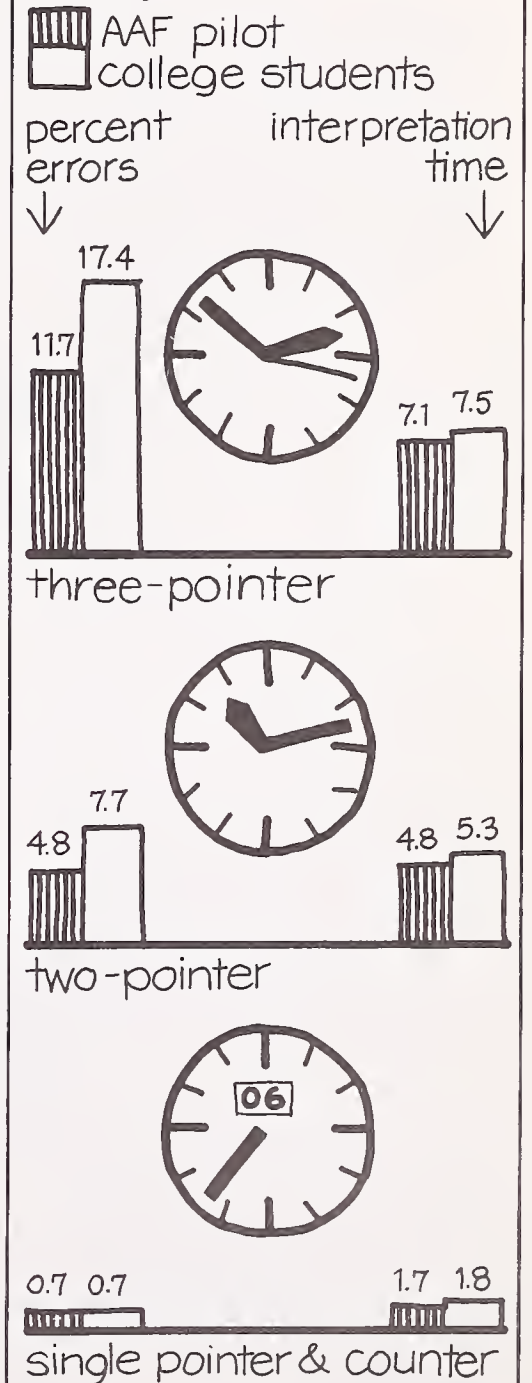

## Movement of People in Buildings

A major activity performed in buildings is the movement of people from place to place. Researchers have studied movement under both realistic and simulated conditions. First, what do we mean by movements? Two types of movement are distinguished by R. Bechtel (psychologist)—*exploratory and habitual*. In an exploratory situation (where a person is in an unfamiliar place), the environment plays a prominent role, by providing cues to those seeking a destination. These cues are not as important for those familiar with a building. This problem has been examined by G. Best (architect) who studied how people find their way in complex buildings and why they become lost. For this study Best chose two buildings in Manchester, England. One building was an old six-story structure, the second a newer eight-story extension. The buildings were connected at the street level and by a third-floor corridor. The circulation patterns were quite complex encompassing a number of dead-end corridors. The buildings were used by as many as 9,000 people a day seeking one or more of 120 locations and using 1 of 10 entrances.

Best identified one room as a destination for the study. He chose a room that was visited quite often both by newcomers and by individuals who had been in the buildings several times. The route required to reach the room was typical of routes taken by most visitors.

“Lostness” was defined as follows: *Any person entering either building at any entrance and intending to go directly to M27 (the experimental destination) will get there most efficiently if he follows one of the experimental routes: a person that unintentionally deviates from one of those routes is direction-finding inefficiently and for the purpose of this study will be considered lost.*<sup>7</sup>

Interviews were conducted with 135 individuals seeking the chosen destination. When they reached their destination the individuals were asked: (1) which entrance they had used; (2) what route they had taken, whether they had been lost, whether they had deviated from the experimental route; (3) how much information they had gained from signs and other individuals (doorman, etc.); and (4) what previous experience they had had in the building.

The results indicated that 56% of the users became lost due to choosing the incorrect floor level. Over one-half of the errors was due to wrong directions given by other people. In general, Best considered that more people became lost with an increase in route length, an increase in changes in route direction, and an increase in route choices.

<sup>7</sup> G. A. Best, “Direction-Finding in Large Buildings,” in *Architectural Psychology: Proceedings of the Conference at Dalandhvi*, ed. D. V. Canter (University of Strathclyde, 1969).

A. Melton (psychologist) observed the way that museum visitors behaved. For example, he noticed that visitors favored right turns—a finding supported by other studies as well, and usually attributed to the fact that most people are right-handed. Melton also indicated that the closer an exhibit was to an exit, the less time that it was viewed. He termed this phenomenon “exit gradient.” Another observation made in the same investigation was the surprising relationship between museum size and the time spent at

each work of art. The larger the museum collection of paintings, the more time devoted to examining each painting. (This finding should be verified before being generalized beyond the study discussed.)

Melton then wanted to determine whether he could alter these behaviors. He modified the number of exits in a museum and installed a number of directional arrows. He was able to change the amount of time an individual spent at various exhibits and in the museum as a whole.

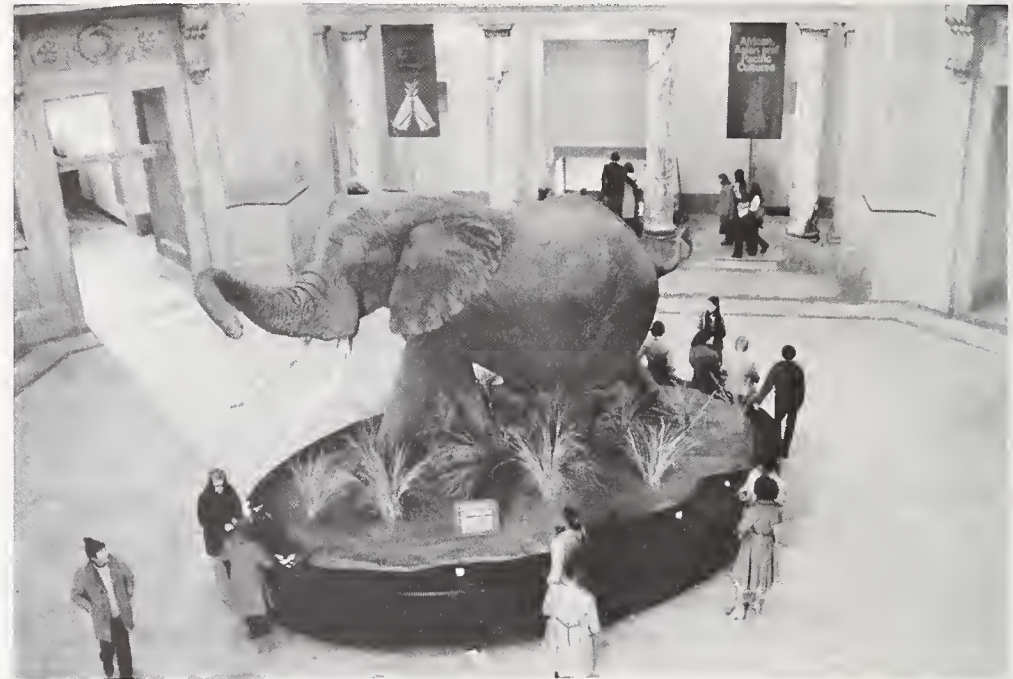

*Museum Visitors (NBS)*



The **odometer**, an instrument which measures foot movement activity, was used by Bechtel to study the relationship between expressed preferences and actual movements, i.e., what people say and what they do. The odometer consists of electrical counters attached to pressure sensitive foot mats which cover a floor space (similar in concept to counters used to monitor vehicle traffic). Carpet is laid over the mats so that the odometer becomes a completely unobtrusive method of data collection. Both locomotion and periods of standing still may be recorded.

The odometer was used to measure exploratory locomotion in a museum of art. Movement patterns of the visitors were recorded. A prediction of the order of preference for each exhibit was made based on the movement patterns. Then subjects were asked to view the exhibits and write down their preferences. The average preferences of the subjects corresponded to those predicted by the movement patterns.

The popularity of various museum displays has been noted by less sophisticated means than the odometer. It was observed that vinyl tiles in front of a display of live, hatching chicks at Chicago's Museum of Science and Industry were completely worn in about 6 weeks. Tiles elsewhere in the Museum lasted for several years. It would be possible to rate the popularity of the exhibits by noting tile wear and replacement rates.

Like Pauls, who studied the movements of large numbers of people, I. Stilitz (British researcher) observed the location and direction of movement of people at automatic ticket machines in underground London subway stations. Each ticket hall was laid out to scale on graph paper. Observations were made during a 40-minute peak period at evening rush-hour. Lines of appropriate length were drawn on the plan to represent the waiting lines. Groups of people were represented by a line enclosing the appropriate area on the plan. Arrows were used to show the direction of traffic flow. Flow routes were noted every 10 minutes for the 40-minute peak period. At the end of every 5 minutes during the peak period, waiting lines and groups of people were recorded. The results indicated some possible design solutions for improving the flow of individuals in the underground ticket stations.

The movements of people in the Museum of History and Industry in Seattle, Washington were studied by G. Winkel (environmental psychologist) and R. Sasanoff (architect). They prepared a series of slides indicating the exhibits. The slides were presented to subjects on three different screens, one in front of the subject, one to his right, and one to his left. The subject viewed the photographs and told the experimenters which way he wished to go: straight, to the right, or to the left. The "trip" continued until the subject indicated that he wished to leave the museum. Each subject's route was mapped and the time he spent in each

location recorded. The results obtained during the slide presentation were then compared with measurements actually taken in the museum. The results indicated a somewhat limited correspondence between the simulation and the real world. The most noticeable difference between the two was the fact that the simulation tended to overestimate the amount of movement actually exhibited when touring the museum. This study points to the need for caution in simulation research.

Closed circuit television and scale models of exhibits were used in lieu of photographs by Bonsteel. The televised simulation permitted smoother transitions in space, greater flexibility of movement, and yielded real time measurements. Disadvantages resulted from the fact that the televised images were black and white, the viewing area was 45° as opposed to the 135° viewing area used with the photographic technique, and the equipment was expensive and complex.

## Movement Simulation Booth (Winkel & Sasanoff)

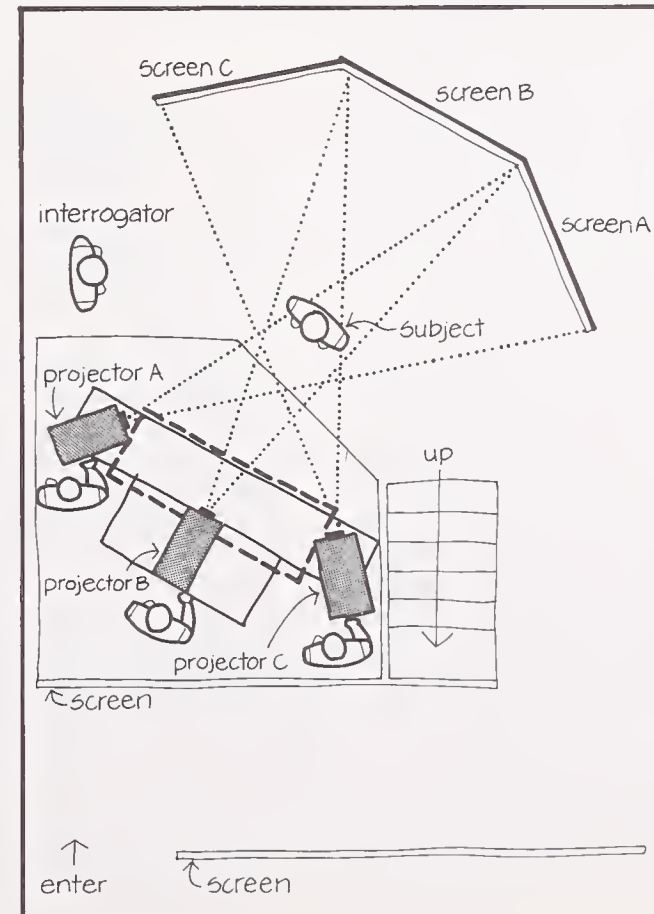



Two Swedish researchers, C. Axel-Acking (architect) and R. Kuller (psychologist), developed a method for allowing individuals to simulate moving through a space using a televised presentation of a scale model.

The design allows the subject to feel he is moving through a large area. A mobile television camera equipped with a **relatoscope** (a long pencil shaped tube with a lens) gives an eye level view of a naturalistic model. The subject views the scene on a television monitor. In front of him is a foot pedal which allows the subject to move the camera over the model; the harder the pedal is depressed, the faster the camera moves. A steering wheel allows the subject to move the camera in a new direction. These changes register immediately on the television screen. By employing different speeds the design can be used to simulate walking, biking or driving.

The subject also has a lever with seven distinct steps by which he can register his perception of the environment he is moving through. This lever acts as a seven-point rating scale.

Finally, the subject's "spot of fixation," or the point at which he is looking at a given time, can be recorded. This is done by lighting one of his eyes with a narrow light beam which is reflected by the cornea and moves along with the eye. An additional television camera records this light beam. This is similar to the eye movement camera approach (see chap. 11).

The information, the view from the model, the semantic rating, and the fixation spot can be recorded on tape. This method was developed as an experimental model to assess various

architectural models. The experimenters have also used recorded background noise to enhance the reality of the visual simulation.

### Televised Presentation of Scale Model (Acking and Küller)

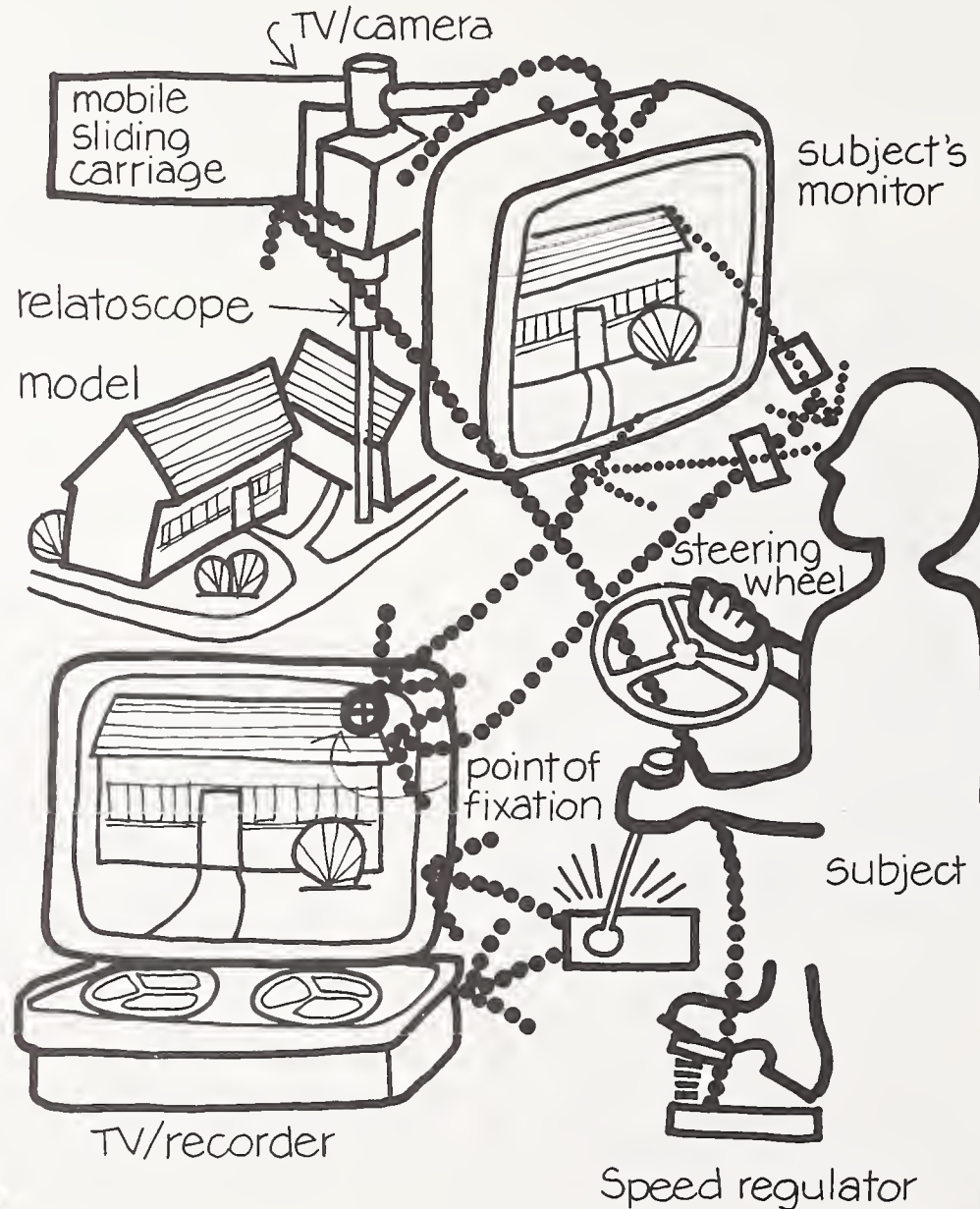

### Conclusion

We have reviewed several problems and approaches dealing with human factors issues. Occupant activities are evidently influenced by many factors, architectural, social, and situational. While the building type is a major determinant of the functions during emergency conditions such as a fire, specialized functions are always an overriding concern. This fact points to the potential conflicts among design goals, e.g., appearance-functional utility; fire safety-security; energy conservation-livability; individual-social needs.

Above all, the user should be considered as an active participant by the architect. For example, in the case of energy conservation, before making firm "hardware" design recommendations, alternative options ought to be carefully explored. A systems analytic approach can be employed to identify these options—which should take into account the capabilities of building users to play a major role in energy conservation programs.

Furthermore, the need to perform research on this topic should receive far greater attention than has been the case in the past where its importance has been noted and then ignored. The systems/human factors approach is likely to greatly increase the number and type of design possibilities that merit consideration and increase the design alternatives available to modify built environments during the lifetimes of buildings. This flexibility would provide the opportunity to respond to new information, technology, and other developments.



# 9

## The Man-Made Environment

### Design and Social Interaction

#### Site Factors

#### Architectural Features

#### High-Rise Buildings

#### Institutional Settings

### Environmental Features

#### Open Space Planning

#### Classroom Design

### Fixed Features—Interior Spaces

#### Stairs

#### Windows

### Movable Features

### Fixed and Movable Space Features

### Conclusion

We have discussed several characteristics of people believed to influence the way they respond to building environments. Now, we are ready to explore a limited number of building and site features and indicate their possible effects on behavior.

L. Festinger (psychologist) suggests that:

*The architect who builds a house or designs a site plan, who decides where the roads will and will not go, and who decides which directions the houses will face and how close together they will be, also, is, to a large extent, deciding the pattern of social life among the people who will live in those houses.<sup>1</sup>*

### Design and Social Interaction

Considerable evidence exists that design characteristics and relationships have an important effect on social behavior. For example, laymen, architects, and researchers note that people tend to socialize with those who are physically nearby; distance is an important determinant of the likelihood of individuals and groups interacting with one another. We will now examine studies concerned with design features of the environment—starting at the macro level and progressing toward a closer look at the links between design and behavior.

<sup>1</sup> L. Festinger, "Architecture and Group Membership," in *People and Buildings*, ed. R. Gutman (New York, 1972).

### Site Factors

Festinger studied the relationship between physical design and the emergence of social groupings in a housing project. Interviews containing questions such as, *What three people in Westgate do you see most socially?*, were carried out in the 13 households in each court. It was found that functional distance between courts, and the direction in which the houses faced were the two major factors affecting the pattern of friendship formation. However, the housing project was unusual in that a great deal of homogeneity existed among the residents, who were all married veteran students at MIT.

Social ties in decaying neighborhoods were the subject of another investigation. Studies of slum dwellers of Boston's West End found that regardless of the physical state of the housing, residents liked the West End and did not want to move. A large component of the favorable attitudes involved social relationships and interpersonal ties. Emotional closeness to neighbors was quite important. (See following page.)

Information about the use of neighborhood space can provide the architect with valuable design guidelines. If the space is used as a play area, the architect will need to know by what age children and for what activities.

G. Coates and H. Sanoff (architect) observed children's activities on the site of a multi-family housing

## Closeness to Neighbors by Feelings about West End (Festinger)

Closeness to Neighbors	Feelings about West End (%)				
	Number of Respondents	Totals	Strongly Positive	Positive	Mixed Negative
Very positive	78	100	63	28	9
Positive	265	100	37	42	21
Negative	117	100	20	39	41

project. They recorded the type of activity, the duration of the activity, the number of children involved, and their ages. The results showed which physical environments were preferred by which ages and for which activities. The authors stress that the study was primarily methodological and that other studies are needed to determine if different physical designs result in different behaviors.

Following the example of K. Lynch (chap. 6), many studies have been conducted to determine the overall impression made by the city. In some instances, sophisticated devices were used to collect the data.

F. Vigier (urban planner) was interested in determining how elements of a city are perceived. He used a tachistoscope (an instrument which allows stimulus material to be exposed for very short periods of time—a sensitive indicator of visual perception) to present wide-angle photographs of Boston streets and squares. Students, some with design

backgrounds and others with non-design backgrounds, were shown the photographs for exposure times beginning with 50 milliseconds and ranging up to 200 milliseconds. Following each exposure, the student verbally reported what he had seen. The information provided by the study allowed Vigier to plot the pattern in which elements were seen and to identify the dominant elements.

## Children's Activities on Housing Site (Coates and Sanoff)



Group Size	Shaded Area
1	
2-3	
4-12	
13 or more	

## Architectural Features

In a recent book R. Sommer (psychologist) discusses architectural features which he feels hinder interaction and lead to feelings of isolation.

Sommer lists the following as the characteristics of **hard architecture**:

*Lack of permeability. A minimum of contact between inside and out. The building has no connection with the surrounding neighborhood. Expensive to construct, alter, or raze, few possibilities for change or expansion without a gross misfit between building and activities. Clear differentiation of status levels. Every activity and person has a specified location. Minimal contact across status levels or departments. Passive adjustment and psychological withdrawal are encouraged. Little possibility for experimentation or change. Rather than relying mainly on the occupants themselves to provide security with outside assistance when needed, security is assigned to a specialized agency. Eventual replacement of security through people by security through machines. Materials and furnishings selected for ease of purchasing and maintenance, producing uniformity in design and layout.*<sup>2</sup>

High-rise buildings often have many of the characteristics of hard architecture.

<sup>2</sup> R. Sommer, *Tight Spaces: Hard Architecture and How to Humanize It* (Englewood Cliffs, N.J., 1974).



## High-Rise Buildings

Although some cities have stopped building high-rise structures, others are just beginning to do so and research is needed to determine the effects of these structures both on the communities in which they exist and on the people who occupy them.

The relative livability of residential blocks with and without high-rise buildings was studied by P. Gelb. Gelb observed outdoor activities on six blocks, three with proportionately greater high-rise floor space contrasting to surrounding low-rise units and three with predominately two- and three-story buildings. Each high-rise block was matched with a low-rise block in terms of city area, physical amenities, terrain, orientation, type of dwelling units, and socio-economic characteristics of residents. Observers were restricted to public walkways and noted the following activities which were chosen as indicative of block livability: conversation groups, relaxation activities, people watching repairs and maintenance tasks, children's play. Results indicated that *the presence of a high-rise building on a residential block appears to have a negative effect on the livability of the block.*<sup>3</sup>

<sup>3</sup> P. M. Gelb, "High-Rise Impact on City and Neighborhood Livability," in *Human Response to Tall Buildings*, ed. D. J. Conway (Stroudsburg, 1977).

<sup>4</sup> B. Ego and R. C. Herrenkohl, "The Influence of Familiarity and Age Factors on Responses to Residential Structures," in *Human Response to Tall Buildings*, ed. D. J. Conway (Stroudsburg, 1977).

In another study, B. Ego and R. Herrenkohl showed observers slides depicting different residential settings. The settings included high-rise buildings, low-rise buildings, row-type buildings, twin or semi-detached houses, garden apartments, single family dwellings, mobile homes, and temporary shelters (tents, trailers). Each slide was rated on degree of crowding, degree of familiarity with type of structure, and desirability as a place to live. Results indicated that *the familiarity rank of a type of residential setting is essentially the same as the desirability rank of that type.*<sup>4</sup>

Institutions are also cited as encompassing many of the characteristics of hard architecture.

## Institutional Settings

The behavior of nurses on two different hospital wards was observed by K. Keleman (psychologist). The first ward was a single corridor design in an old hospital. The behavior of six nurses was observed and recorded in five major categories: interaction with people; interaction with objects; communication; posture; activity being performed. The same six nurses were then observed after they had moved to a new hospital with triangular-shaped wards. The differences between the two settings were fewer and smaller in magnitude than Keleman had expected. One interesting finding was that walking increased on the triangular ward; the triangular ward had been designed to reduce the amount of walking required.

## Single Corridor Wards (Keleman)



## Triangularly Shaped Wards (Keleman)

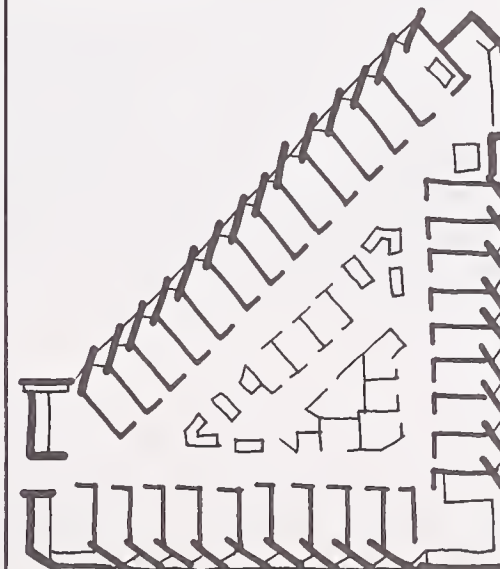

Another study noted changes in behavior after physical changes were made on a custodial care ward. B. Hartford and W. Kleeman (interior designer) first observed and coded the behavior of individuals on the ward and found very little interaction. Several physical changes were then initiated such as curved continuous seating in conjunction with activity areas; tables used with the seating; a small kitchen and laundry area; and finally, a personal area where individuals could keep possessions. Observations after these changes showed that interaction more than doubled.

College dormitories or residence halls may also be considered institutional environments. The satisfaction of college students with their residences was explored by G. Davis and R. Roizen. The researchers designed a questionnaire which looked at overall satisfaction as well as satisfaction with 25 specific environmental variables. The questionnaire was given to students on eight campuses, occupying a variety of housing types. The housing types included conventional long corridor dorms, suites, apartments, and housing complexes. Particular environmental features had very little effect on overall student satisfaction. Instead, satisfaction was related to the general type of residence hall. Conventional long corridor dorms were the least liked while apartments were rated as very satisfactory.



## Environmental Features

Another basic concern for the architect is to determine how particular environmental features affect building occupants. Although considerable M/E research has addressed this issue, definitive findings are few.

## Open Space Planning

The concept of open space or open office planning began in Germany in the 1960's. At that time, open office planning or office landscaping meant the absence of partitions, a scrambled furniture arrangement and large plants located throughout the space. The purpose of this design was to facilitate communication among staff members. This concept, with variations, is now being used in offices throughout the world.

Most of the studies done to assess open office planning have employed questionnaires and more specifically the semantic differential. Few studies have used control or comparison groups so that the responses obtained in the open offices could be compared with responses obtained in traditional offices.

One study which did have a control group is reported by P. Boyce. In 1971, in Bristol, England, the South Western Electricity Board centralized its operations and moved staff from several buildings to a large new building in which almost all the office space was open-plan. Researchers were aware that past studies had indicated some disadvantages associated with open-plan offices such as distractions, loss of privacy and status, and loss of individual control. Questionnaires were designed to assess response to the new building.

The questionnaires were administered to the staff both prior to and after the move to the new building. Briefly, results indicated improved communications in the new building and satisfaction with lighting and windows. There was dissatisfaction with the heating and ventilating systems and complaints about noise although noise complaints were also evident in the older buildings. A literature survey indicated that responses to the new open-plan building were similar to responses to open-plan buildings in other parts of the world.



Open Office Layout (NBS)

Another study of employee attitudes to old traditional office space and to a new open-plan space was conducted by M. Brookes. A semantic scale was given to each employee before the announcement of plans to move to a new space and nine months after the move to the redesigned space. Each employee was asked to respond to the semantic scale in three different ways. First, to describe the present office workspace; then, to describe an ideal office workspace; and, finally, to describe the way co-workers would want the office workspace. The open-plan office rated higher in aesthetic value and lower in the areas of noise, visual distractions, and privacy.

Open space planning is also being applied in classrooms.

## Classroom Design

As two researchers, C. Porteous (psychologist) and J. Porteous (geographer), note:

*Disillusionment with the traditional classroom has grown with the realization that during the lengthy learning day the child may require varying environmental conditions, whether of humidity, temperature, decor, or furniture arrangements. This recognition of learning as a dynamic process has led to attempts to manipulate the physical learning environment so that the child's learning advances with optimum speed and minimum stress. Since the 1950's there has been a concerted move toward open-plan classrooms, where the walls as well as the furniture are removable or capable of rearrangement in a variety of desired patterns.<sup>5</sup>*

<sup>5</sup> C. W. Porteous and J. D. Porteous, "The Learning Environment: Enrichment or Impoverishment?," in *Proceedings of the Symposium on Environmental Effects on Behavior*, ed. W. D. Bliss (Bozeman, Montana, 1975).



In a study concerned with open-plan classrooms, J. Durlak et al. observed students in traditional plan schools and open-plan schools. Four traditional plan schools and four open-plan schools were matched on the basis of geographical proximity, size of student body and general demographic status of the neighborhood. The researchers made systematic observations and recorded information about the general structure of the area, the teacher's style, the activities of the students, and the dispersion of people in the spaces. The results demonstrated that there were different general activity patterns in each type of school. It is now necessary to determine if these different patterns have different effects on learning.

The effect of environmental complexity on learning behavior was explored by Porteous and Porteous. The study took place in three different classrooms of high, medium and low complexity levels; and at two grade levels, third and fifth. The children were required to learn a paired-associate task with both a time limitation and a number of trials limitation. There was a one-way mirror so that the children's attention or "looking behavior" could be observed. *The dependent variables were, therefore, number of correct items on the learning task, and attention to the environment.*<sup>6</sup> Children at both grade levels performed better in the less complex environment.

## Fixed Features—Interior Spaces

E. Hall (anthropologist) makes an important distinction between two different types of environmental characteristics. He describes environmental characteristics in terms of being **fixed-feature space** and **semifixed-feature**. A fixed-feature space is typified by specialized rooms, buildings and towns which tend to shape behavior. The user has only a limited ability to modify its primary features (for example, a bathroom). In contrast, a semifixed-feature space is one where limited environmental modification is acceptable and possible (for example, the furniture arrangement in a living room). Hall emphasizes that in part the fixedness of features is culturally determined. (For example, in China, chairs are considered fixed features despite the fact that they are movable.)

<sup>6</sup> Porteous and Porteous

The Swedish Institute for Building Research has pioneered many M/E areas dealing with interior building spatial requirements. One such investigation, performed by M. Englund and G. Hallberg was concerned with determining the size of the free space needed on each side of a door, in order to freely open and close the door.

The study was conducted by having research subjects open a door, 90 cm wide (height not indicated), while the activity was recorded by a television camera. The floor was marked with a 20 cm grid, and the wall area near the door was marked off in 10 cm increments. Experimental subjects wore numbers to ensure identification during later analysis. (This procedure was required because the faces of the subjects were not always visible.) The research approach enabled the experimenters to specify the space requirements for door clearance—for the conditions studied.

## Space Requirements for Doors (Englund and Hallberg)

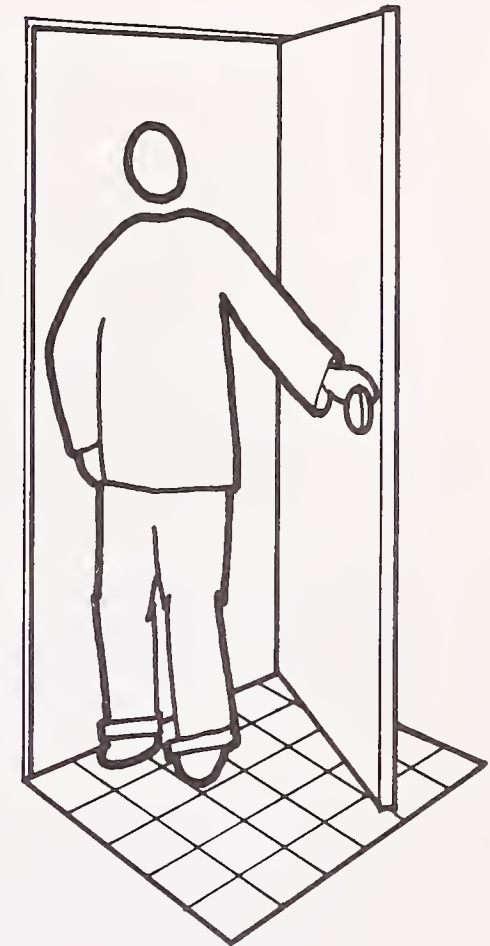

R. Blake (psychologist) et al. conducted a study in an Air Force barracks to determine the effect of room arrangement on the interactions of the occupants. Open and closed cubicle barracks were used in the study, and in both types of barracks, bunks were segregated into units of six each. The only difference between the two types was that the closed cubicle barracks had walls which enclosed each unit of six bunks, with entrances from which doors were removed. The subjects were asked to indicate the degree (on a 4-point scale) to which they interacted with others and to identify the three men with whom each man preferred to "buddy." The open design fostered closer relationships in the barracks than the closed one.

The ceiling height of an experimental room was altered by J. Savinar in a study of personal space needs. The room was 16 ft. by 12 ft. (4.8 m by 3.6 m) on one wall. The ceiling was made of white translucent fiber glass and was adjusted to heights between 6 ft. (1.8 m) and 9 ft. (2.7 m) by means of a pulley system. Savinar asked subjects to determine their "comfort threshold"—the point below which the ceiling space became inadequate. The ceiling was alternately lowered from 9 ft. (2.7 m) and raised from a point below the preceding trial. The standing heights for all subjects (male and female) were recorded beforehand. The results indicated considerable variability from subject to subject (81 in. to 102 in.) (205 cm to 259 cm) not attributable to height or sex.

In a follow-up study, the same researcher examined the effects of two ceiling heights (6 ft., 9 ft.) (1.8 m, 2.7 m) on personal space needs. She positioned each subject in the room, and then approached the subject, who was instructed to say "stop" when personal space was perceived to be invaded. The floor was then marked to indicate how closely she had approached the subject. Ceiling height did not affect the invasion distance.

Other building features receiving attention from M/E researchers are stairs and windows.

### Stairs

Vertical movements by means of stairs pose a special challenge to the architect. Stairs, while essential to buildings, also are a threat to their users. They are a hazard because many accidents occur when people ascend and descend them; many severe accidents occur during descent.



*An Accident on Stairs (NBS)*



A series of studies to verify the adequacy of current stair design practices was performed by J. Fitch (architect) et al. Current stair designs can be traced to the work of Francois Blondel, Director of the Royal Academy of Architecture in Paris (1672). Fitch and his colleagues indicate that Blondel:

*Concluded from personal observation that the normal pace in level walking (24 inches, he said) must be decreased by a regular and fixed amount to allow the foot to be raised in climbing stairs. Blondel derived a formula stating that the pace must be decreased by two inches for every inch of riser. Expressed mathematically, the formula specified that the depth of the tread should be 24 inches minus two times the height of the riser, or that the total of the tread and two times the height of the riser should be 24 inches.<sup>7</sup>*

The authors of the study note that Blondel's formula often leads to stair designs which are too wide or too narrow. They also indicate that, despite the fact the average person today is taller than his 17th century counterpart, many building and fire codes specify the stair dimensions recommended by Blondel. The research performed by Fitch and his colleagues was designed to improve the basis for recommended stair design.



*Approach To Temple of 1000 Steps, Seoul, Korea (Authors)*

One study consisted of building replicas of four different stairways each one consisting of four steps. The angle of ascent ranged from 7.7 degrees to 36.8 degrees (New York City code). Men and women wearing ordinary clothing walked up and down the stairs and were photographed while doing so. Their next investigation employed a mechanical stairway, which permitted an increased number of variables to be studied. They examined three angles of pitch (25, 35, 45 degrees), three different riser-tread combinations and three speeds of movement (controlled by the mechanical treadmill). Subjects wore special overshoes, equipped with pressure sensitive stitches which permitted measurements to be made of the length of time that the toes and heels were in contact with the stair treads. They found that: (1) more missteps occurred during descent and (2) the safest stair configuration for descent was not the same as that for ascent. The stair design problem obviously needs further work.

J. Archea (psychologist) studied the relationship of stairs and accidents. A television camera was positioned at stairway locations to enable video recordings to be made of people as they ascended and descended. Data were collected at several sites, which differed primarily with respect to stairway design. In this way, many accidents and near-accidents (critical incidents) were recorded and later analyzed.

<sup>7</sup> J. M. Fitch, J. Templer, and P. Corcoran, "The Dimensions of Stairs," *Scientific American*, 231 (1974).



## Windows

As energy conservation considerations have become more critical, designers and engineers have begun to pay more attention to the size, shape, and type of windows which are put into buildings. Investigators have attempted to define a range of acceptable window sizes and shapes through the use of scale models. A scale model allows a person to change the size, shape, and location of a window to suit his own particular preference. The model can even be equipped with miniature furniture to simulate either a home or an office environment. In addition, the experimenter can vary a large number of parameters including view, building orientation, and type of glazing.

In an investigation of minimum acceptable window size, E. Ne'eman (Israeli engineer) and R. Hopkinson (British researcher) employed a full-scale model and a 1/10-scale model. Three hundred and nineteen subjects determined minimum acceptable window size as a function of the dimensions of the room, the number of apertures, the outside view, the weather, external illumination levels, and two window heights. The results indicated that the subjects could identify a minimum acceptable window size both with the full-scale and with the 1/10-scale model. Type of view proved to be an important determinant of acceptable window size.



*Small Windows (NBS)*

E. Keighley (British researcher) developed a scale model technique to investigate the visual requirements associated with windows. A 1/12-scale model was constructed and furnished to give a realistic impression of a landscaped office. The model was furnished with a window which could be controlled with respect to configuration by means of a pushbutton control panel—the total window area being fixed at 30% of the window wall. Beyond the window was a large translucent screen upon which a view was projected by means of eight color transparencies simulating different views as seen from different floors of a building.

Keighley had 30 subjects view the model as if it were their office. They were then asked to adjust the shape and location of the window to the most desirable dimensions. The subjects preferred a wide lateral scan and selected settings which produced wide rather than tall windows.

In another investigation employing the same general approach, Keighley used a series of templates to define window configuration. Subjects were asked to judge the acceptability of each arrangement on a 5-point scale (from “entirely satisfactory” to “very dissatisfactory”). Keighley found that, when total window area was restricted and the number of apertures varied, subjects were dissatisfied with a large number of apertures and with very narrow apertures. Satisfaction with window height was dependent upon the view.

## Layout of Model (Keighley)

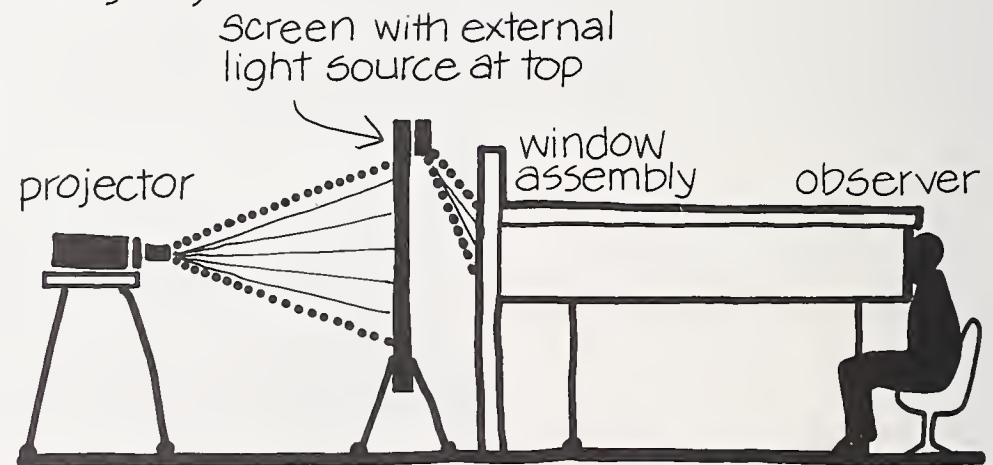

A sample of templates used by Keighley:





Window research studies have also examined the concept of spaciousness. M. Inui and T. Miyata (Japanese researchers) defined spaciousness as *the feeling of openness or enclosure produced by an interior*.<sup>8</sup> Inui and Miyata used several models (1/20, 1/10, and 1/5-scale) and evaluated the impact of such variables as daylight, sunlight, window size, and room volume upon perceived spaciousness. Results indicated that window size had the greatest effect upon perceived spaciousness. The results did not vary with the size of the model used.

Perceived spaciousness was also studied by V. Imamoglu (Turkish architect) and T. Markus (Scottish architect). They used both a full-scale and 1/10-scale model. Unlike Inui and Miyata, who had their subjects rate the spaciousness of different rooms, Imamoglu and Markus asked subjects to adjust each of two rectangular models to be equal to a fixed square model in spaciousness. The effects of window size, room proportion, and length of window wall upon spaciousness were assessed in this manner. Unlike the findings of Inui and Miyata, window size and perceived spaciousness were not found to be highly correlated.

The results of these two studies indicate that subjects can define and use a concept termed "spaciousness" fairly consistently. This concept is related to but not entirely dependent upon, the presence of windows within

a room. Thus, a large windowless room, with a high ceiling, large volume, and bright lighting could be judged as spacious, although it probably would be judged as more spacious if a window were present.



Scale Model of Room (Keighley)

<sup>8</sup> M. Inui and T. Miyata, "Spaciousness in Interiors," *Lighting Research and Technology*, 5(1973).



Windowless Space (NBS)



## Movable Features

R. Sommer (psychologist) conducted several studies to determine how furniture arrangements in a classroom influenced participation by students.

In the first study, student observers recorded classroom interaction in 51 different classes. Results indicated that class size influenced student participation, but at the same time the actual *number* of students participating was similar for small, medium and large classes. The observers then rearranged the chairs from straight rows to a circular pattern. This change was made before anyone

arrived in the classroom. Results indicated that 20 of the 25 classes rearranged the chairs in straight rows prior to the start of class. Sommer interprets these rather discouraging results as an indication of how easily and unconsciously people adapt to traditional ways of doing things.

In a second study, observers recorded participation in laboratory settings—a more open arrangement than that found in the classroom settings. Both the total time of participation and the proportion of students participating were high (24% of class time compared with 12% found in the study of regular classrooms).

## Study of Classroom Size and Participation (Sommer)

	Class Size		
	Small (6-20)	Medium (21-50)	Large (50+)
Number of Classes	12	12	27
Above Median Participation	75%	50%	37%
Below Median Participation	25%	50%	63%
Average Total Time of Participation	5.8 Min.	2.4 Min.	2.6 Min.
Average Number of Different Students Participating Per Session	6.9	6.7	6.9



Movable Features—Sommer (NBS)



## Fixed and Movable Space Features

A. Maslow and N. Mintz (psychologists) conducted a study to determine the effects of room features on the task of evaluating facial photographs.

Three rooms were used by subjects who evaluated facial photographs on the amount of fatigue-energy and displeasure-well-being displayed by the individual in the photograph. The experimental rooms differed in terms of characteristics and furnishings. The rooms were evaluated as being "ugly," "average," and "beautiful."

The "ugly" room was described by people as being horrible, disgusting, ugly, and repulsive. It was 7 ft. x 12 ft. x 10 ft. (2.1 m x 3.6 m x 3.0 m) with two half-windows, battleship-gray walls, and one overhead bulb with a dirty, torn lampshade. The room contained two straight-backed chairs, a small table, and tin cans for ashtrays. The window shades were torn, the walls were bare, and refuse and cleaning implements were scattered around. The room had not been swept or dusted and the ashtrays were full.

The "average" room was a professor's office with three windows, battleship gray walls and an indirect overhead light. The room was 15 ft. x 17 ft. x 10 ft. (4.5 m x 5.1 m x 3.0 m) and furnished with two mahogany desk and chair combinations, two straight-backed chairs, a metal filing cabinet, a metal bookcase, window shades, and a cot with a green bedspread. The general appearance

was that of a clean, neat and worked-in office.

People responded to the "beautiful" room as being attractive, pretty, comfortable and pleasant. The room was 11 ft. x 14 ft. x 10 ft. (3.3 m x 4.2 m x 3.0 m) with beige walls, an indirect overhead light and two large windows. The furnishings gave the appearance of a comfortable and attractive study and included a soft armchair, a mahogany desk and chair combination, a wooden bookcase, a small table, two straight-backed chairs, drapes for the windows, a large Navajo rug, paintings, and some art objects and sculpture on the desk and table. The beautiful room resulted in higher ratings in well-being and energy than did the others.

Mintz continued this study and demonstrated that *these effects are not limited either to "laboratory" situations or to initial adjustments, but can be found under naturalistic circumstances of considerable duration.*<sup>9</sup> Mintz instructed examiners to spend two hours per week for three weeks testing subjects on their reactions to facial photographs. The examiners were *unaware* of the purposes of the study and switched rooms on alternate weeks. The subjects in the beautiful room had ratings which were higher on the energy and well-being dimensions throughout the study. The examiners in the "ugly" room consistently finished testing in less time than the examiners in the "beautiful" room. These results indicate that the appearance of an individual's surroundings can have an effect on the individual and on the activities being performed.

## Room Evaluation Study (after Maslow and Mintz)

"Ugly Room"



"Average Room"

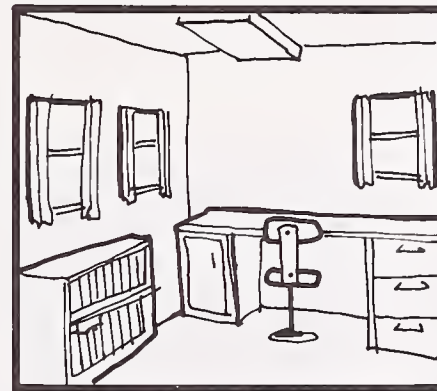

"Beautiful Room"

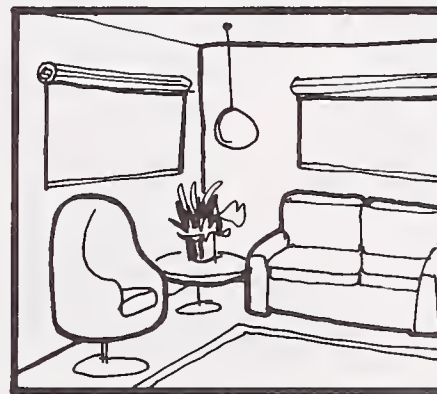

## Conclusion

As indicated in previous chapters, the primary interest of the behavioral scientist concerns how characteristics of people influence the way they respond to building environments. This chapter has looked at how building and site features can affect behavior. This area deals with environmental effects and, while of primary importance to architects and in some cases the regulatory community, it is of secondary concern to behavioral scientists. We will now consider an area of major concern to behavioral scientists—the sensory environment.

<sup>9</sup> N. L. Mintz, "Effects of Esthetic Surroundings: II. Prolonged and Repeated Experience in a 'Beautiful' and an 'Ugly' Room," in *People and Buildings*, ed. R. Gutman (1972).

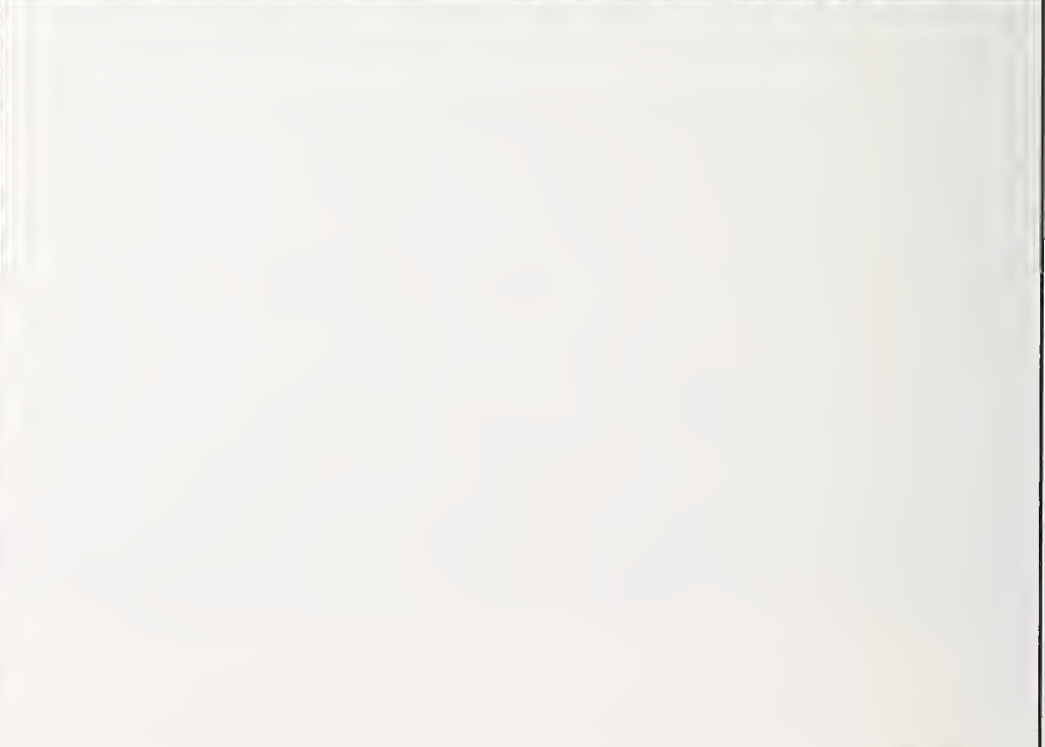



# Part IV

## Well-known Senses—Hearing, Vision

Buildings are sometimes described in terms of forming a specialized environment suitable for conducting the activities of those who occupy them. The users of buildings experience these environments by means of their senses. The ability to see, hear, touch, etc., has a physiological basis among man and animals, which has been studied since the time of the earliest physiological, medical, and psychological researchers. This subject area is therefore a voluminous and broad-ranging one. Due to the wealth of potentially relevant information, however, we can only suggest the variety of approaches and findings available—particularly in the instances of visual and auditory research, which have received considerable attention. Unfortunately, while the amount of information available on sensory stimulation is substantial, the findings directly applicable to buildings are limited.

The fact that people rely primarily on sight and hearing in their day-to-day activities provides sufficient reasons for researchers to pay more attention to these senses than the others. There is another reason to concentrate on visual and auditory research; these areas can be readily studied in the laboratory using research procedures following classical psychophysical methods. Most laboratory studies are performed by collecting data on one experimental subject at a time, using psychophysical procedures. Since these procedures are very time-consuming and costly, the number of subjects participating in a study is usually limited to no more than 20. The relatively small number of subjects is offset by the large number of measurements obtained from each experimental subject. Subjects are carefully screened to ensure that they have normal sensory abilities (e.g., normal vision) before participating in a study.

Environmental research is by no means limited to laboratory investigations. In recent years, there has been an emphasis on obtaining findings in realistic settings by conducting community studies. These investigations have used observational techniques and questionnaire surveys. Among M/E researchers, there is a strong trend toward more field research in the actual environments being studied.

Building users depend upon their eyes and ears for most of their information about the environment. Studies of how we see and hear also constitute the preponderance of traditional experimental research in psychology, dating from the nineteenth century. Visual research in particular encompasses so many problem areas of direct interest to M/E issues that the subject is subdivided into three chapters in this part.

Chapter 10 describes noise as a major problem for building users. It reviews acoustical criteria for spaces and materials and describes the development of rating schemes used to evaluate the effects of noise on people.

Chapter 11 presents an overview of studies dealing with visual perception. Gestalt and traditional research approaches and findings are discussed.

Chapter 12 focuses on illumination requirement measurement procedures. Quantitative and qualitative factors are described and research methods discussed. Threshold and suprathreshold measurement methods are indicated.

Chapter 13 deals with color as an aspect of the visual environment. The effects of lights on color perception are mentioned as are color harmony factors. The development of color classification schemes is also described.

# A Schematic Diagram of How the Human Ear Functions

When you hear:

1. Sound waves enter your ear, travel through the auditory canal, and set up vibrations in the eardrum.

2. The vibrations of the eardrum cause the bones in the middle ear to move back and forth like tiny levers. This lever action converts the large motions of the eardrum into the shorter, more forceful motions of the stapes.

3. The footplate at the inner end of the stapes moves in and out of the oval window at the same rate that the eardrum is vibrating.

6. In the brain the impulse is translated into the sensation you know as sound.

4. The movement of the footplate sets up motions in the fluid that fills the cochlea.

5. The movement of the fluid causes the hairs immersed in the fluid to move. The movement stimulates the attached cell to send a tiny impulse along the fibers of the auditory nerve to the brain.

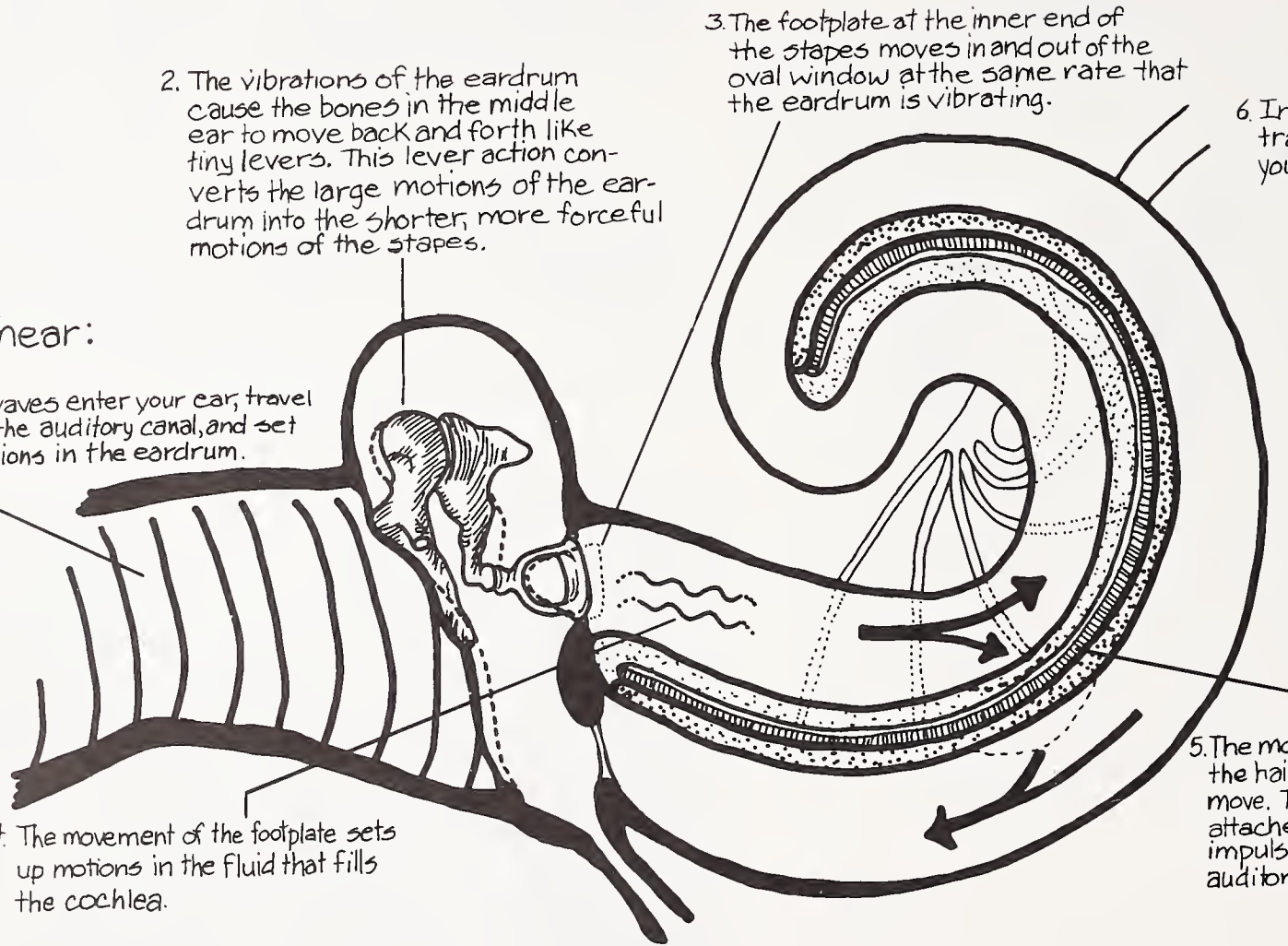



# 10

## The Auditory Environment

The Noise Problem

The Auditory Evaluation of Buildings

Noise Criterion (NC) Curves

Sound Transmission Class (STC) Ratings

Auditory Privacy

Speech

HUD Guideline Procedure

Loudness Level

Perceived Noisiness

Source Noises—Aircraft, Traffic

Hearing Impairment

Conclusion

### Decibel Scale for Sounds

Physical damage  
(jet takeoff)

Painful  
(siren)

Deafening  
(power mower)

Very Loud  
(cocktail party)

Loud  
(traffic)

Moderate  
(conversation)

Faint  
(rustling leaves)

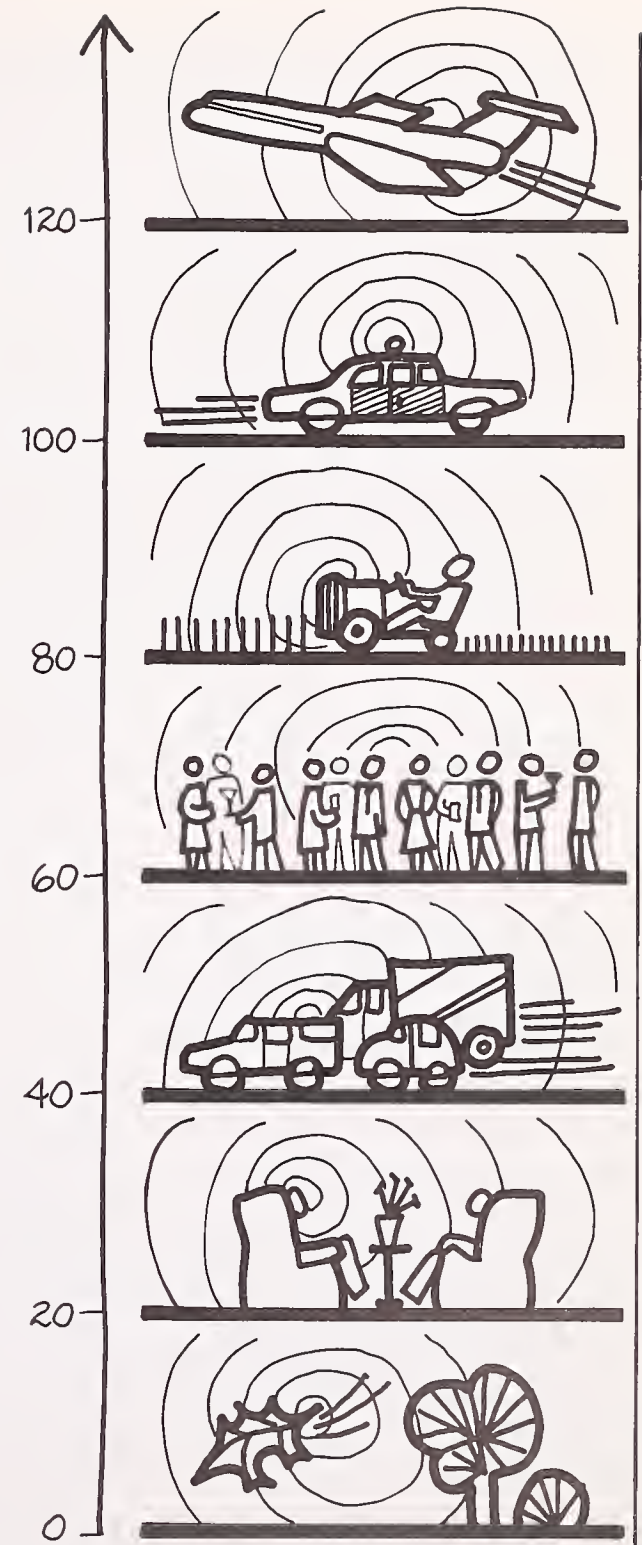

Noise is an increasingly disturbing part of our environment. The advent of lightweight construction techniques and open-space planning designs have contributed toward this trend. Unfortunately, research studies to determine the effects of noise on people have not been directly applicable to design requirements. Building occupants are exposed to many different noise sources which have immediate (e.g., speech interference) and cumulative effects on people. However, individual noise rating schemes, developed to assess particular noises (e.g., aircraft, automobile) are difficult to relate to one another and their combined effects are difficult to determine. Consequently, existing acoustical design guidelines are sometimes based on tenuous judgments.

In common with other environmental research areas, few formal studies have been designed to investigate the positive attributes of sound. Expert judgment has typically been the basis for design decisions for those spaces where the characteristics of sound are especially important (e.g., concert halls and theaters). To the extent that it has been possible to specify desirable characteristics such as volume and warmth in terms of reverberation time and diffusion, the acoustician has usually served as the expert. In other instances, judgments are made by artists, managers, or owners of the building, largely based on aesthetic preferences or past experience.

Of course, a concert hall is not the most common space designed by an architect. Almost every building has requirements for enhancing, or at least permitting, activities to be performed which are largely auditory. For example, a living room can be expected to be used for conversations, listening to music and watching/hearing television. Acoustical criteria and rating schemes have been developed to indicate the background levels of sound compatible with activities performed in the home: living rooms, bedrooms, kitchens, etc. Criteria are also available for other building types such as offices, hospitals, and libraries.

What is critical to the architect is the relationship of these rating schemes to design. There are reasons to believe that their usefulness is limited under present-day design practices in the United States.

Another aspect of the acoustical environment of concern to the architect is the disruption of desired activities by noise—defined as unwanted sound.

To prescribe design goals for the auditory environment in the household, for example, one must first determine the nature of the activities to be performed, and the possible impact of the auditory environment. Activities are likely to include reading, watching TV, listening to music, performing household tasks (cleaning, food preparation), engaging in hobbies, eating, sleeping, convalescing from illness, and many others. One would then tentatively plan where these activities are likely

to be performed in order to minimize conflicts among incompatible ones (woodworking in a home workshop and conversing).

One of the simplest ways to reduce noise is to separate noise-producing equipment and activities from spaces which require quiet.

## The Noise Problem

People living in the inner cities often think of noise as a necessary price to pay for the convenience of living either near their places of work or close to public transportation routes which can be used for commuting. However, in recent years the number of people affected by urban noises

has been greatly increased as a result of urban sprawl.

The most dramatic change in the scope of the noise problem has been a systematic invasion of noises outward from the city into the quietest areas of the nation. Suburban areas have been converted to urban, farm to suburban, residential to industrial. For example, construction of an industrial plant results in a considerable change in outdoor noise levels because of the many factors associated with new industry. Road, rail lines, and/or airport facilities are needed, parking and housing for new workers may have to be provided and community services increased.



*Noise Pollution (EPA Documerica)*



Two design approaches have increased the exposure of building occupants to noise. First, the lightweight construction methods used in recent years have reduced the barriers between noise producers and those affected by noise. Second, the increasing use of open-space planning has eliminated many barriers, thereby markedly altering the noise climate. Ironically, the design of open offices

frequently includes the deliberate introduction of noise sources as an aid to privacy and to mask other sounds!

Noise therefore has a very widespread influence on the adequacy of many building environments and poses a major challenge to the architect. Before noise can be dealt with effectively, however, the ways in which it is manifested must be understood.



*Open Office Noise Exposure (NBS)*

Noise has a number of characteristics in common with other environmental pollutants such as solid and liquid waste and particulate matter in the air. Its effects are biological, psychological, and sociological. Another shared feature is the difficulty in establishing simple cause-and-effect relationships between the pollutant and its consequences. (For example, just as we do not know the effects of long-term exposure to minute quantities of toxic chemicals found in our drinking water supply, the long-range consequences of low level (below 85 dBA) noises are unknown.) Finally, a broad range of effects has been attributed to noise. At one extreme, a loud explosion can destroy the sensory perception of the ears and cause total deafness. At the other extreme, temporary physiological changes often accompany exposure to moderate levels of noise; for example, changes in heart rate and blood chemistry. Most available findings fall between these extremes.

To complicate the situation, the quality of information concerning noise effects is not uniform—it differs from discipline to discipline. Physiological consequences, such as causes of permanent hearing damage are better understood than psychological ones, and both of these disciplines are further advanced than sociological research in their studies of noise effects.

Let us first consider a number of the severe effects sometimes caused by noise. Noise can cause permanent hearing impairment under some circumstances. The industrial setting is the most likely locale for this to occur though in few environments are people completely protected from levels of noise which can cause deafness. This hazard is very real, yet in most design situations noise poses a psychological rather than a medical problem. The most typical reaction of the layman is that noise is a nuisance; it interferes with many activities. This latter problem is perhaps best illustrated by the detrimental effects of noise on the understanding of speech.

Perhaps the most prevalent, most researched and still least understood behavioral effect of noise is its disturbing and annoying quality. Since even these descriptive terms are highly subjective, the development of a general methodology which adequately relates, in quantitative terms, the physical characteristics of sounds with the psychological responses to them has been very difficult.

## The Auditory Evaluation of Buildings

In designing an auditory environment, the architect has a number of guides, developed primarily by acousticians. For the most part these criteria describe the acoustic environment of spaces, on the one hand, and the noise transmission characteristics of building components (e.g., walls, floor/ceiling assemblies) in the other instance. The adequacy of these working tools depends on their relatedness to the behavior and activities performed in a building. For example, a given **noise criterion** (NC) curve is associated with a noise level appropriate for an activity such as sleeping. The curve is therefore an appropriate design tool if adequate data exist demonstrating that, at the selected level, people can sleep, whereas sleeping is difficult at the next highest NC level. In a similar fashion, **sound transmission class** (STC) ratings have been developed to enable the architect to design a space using built elements having predetermined sound transmission loss characteristics. For example, if a room housing quiet activities (e.g., reading) is to adjoin one which is likely to be noisy (e.g., kitchen), then the wall between these rooms should have good sound insulation properties.

In both instances (NC curves, STC ratings), the adequacy of criteria depend on the quality of the research data used to formulate them. We will now briefly review their development, using a recent study by S. Yaniv (bioacoustician) and D. Flynn (physicist) as the source document.

## Noise Criterion (NC) Curves

The original purpose of the NC curves was to lower the number of complaints by those being disturbed by noise. They were intended to specify the maximum noise levels which can be present in an environment without eliciting complaints. The levels were analyzed in terms of octave bands and the noise was assumed to have a continuous noise spectrum. The NC curves were developed by L. Beranek (acoustician) on the basis of opinion/attitude surveys of office workers. The researchers questioned the workers regarding the effects of noise on their ability to perform their work assignments and to communicate by speech. The responses to the questionnaire items were correlated with physical measurements of the noise. The currently used NC curves were a refinement of earlier **speech communication** (SC) criteria curves, and are now being modified to **preferred noise criteria** (PNC) curves.

## Noise Criteria (NC) Curves

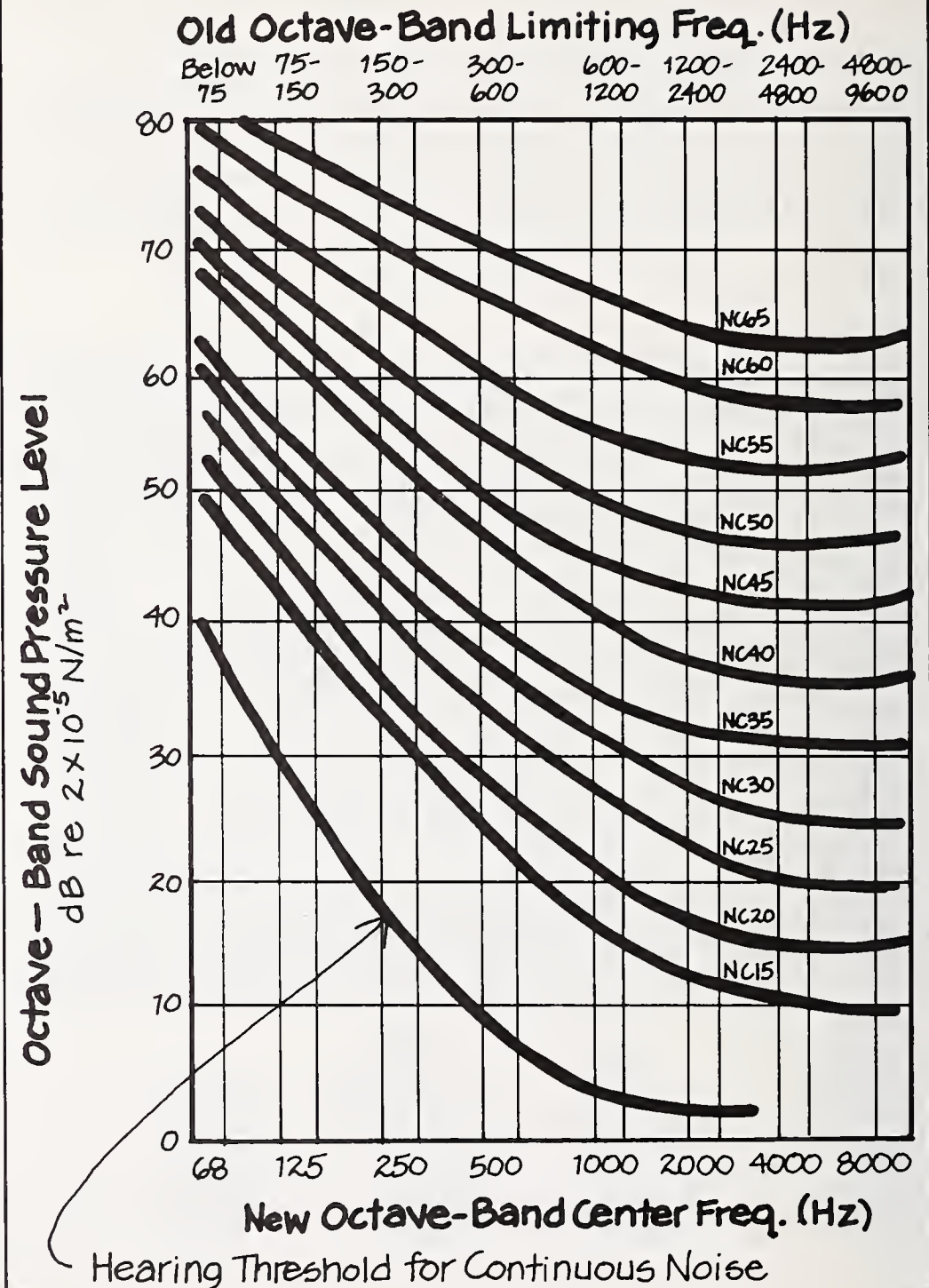



Beranek later had a questionnaire administered to 190 people near an Air Force base. The rating scales were produced in the following way. He had the subjects evaluate the noisiness of their environment and the degree of interference with speech communication. Physical measures of the noise were also made, as were **speech interference levels (SIL)**. (SIL is the arithmetic average of the sound pressure levels of noise in the three octave bands centered on the frequencies of 500, 1000, and 2000 Hz, respectively.)

The study indicated that speech communications were an essential part of their activities and that intense office noises interfered with these communications. As a result of these findings, criteria for maximum permissible noise levels were established in terms of SIL and loudness levels. The study data indicated that when loudness levels were 22 dB greater than SIL, there were no objections but when they reached a level of 30 dB above SIL, complaints occurred.

### Speech Interference Levels (SIL) and Noise Criteria (NC) Recommended for Rooms

Type of room	Maximum permissible level (measured in vacant rooms)	
	SIL	NC
Secretarial offices, typing	60	50-55
Coliseum for sports only (amplification)	55	50
Small private office	45	30-35
Conference room for 20	35	30
Movie theater	35	30
Conference room for 50	30	20-30
Theaters for drama, 500 seats (no amplification)	30	20-25
Homes, sleeping areas	30	20-25
Assembly halls (no amplification)	30	
Schoolrooms	30	25
Concert halls (no amplification)	25	15-20

Source: SIL data from Beranek and Newman as modified by Peterson and Gross to reflect current practice of using octave bands with centers at 500, 1000, and 2000 Hz; NC data from Beranek.

### Speech-Interference Levels that Barely Permit Reliable Conversation

Distance between talker and listener (ft)	Speech-Interference level (dB)			
	Normal	Raised	Very Loud	Shouting
0.5	71	77	83	89
1.0	65	71	77	83
2.0	59	65	71	77
3.0	55	61	67	73
4.0	53	59	65	71
5.0	51	57	63	69
6.0	49	55	61	67
12.0	43	49	55	61

### Sound Transmission Class (STC) Ratings

STC ratings, like the NC curves, were developed in response to a criterion of "minimal complaints," rather than optimal acoustical performance. As noted by Yaniv and Flynn: *Historically, tenant complaints came about at a time when the building industry was departing from traditional masonry construction practices and moving toward the use of lightweight, prefabricated structures. In older construction, where the rate of tenant complaints was low, dwelling units were often separated by a 25-cm plastered brick wall whose massiveness was intended primarily to serve as a fire wall. The smoothed transmission loss curve for this brick wall was*

*taken as the criterion against which other structures should be judged. If the transmission losses of a given partition are found to exceed those of the grading curve at all frequencies, the partition is clearly acceptable. If the transmission losses at all frequencies are found to be poorer than those specified in the grading curve, the partition is clearly unacceptable. Most partitions, however, are neither all "good" nor all "bad."*

The rules employed to make evaluations which are not clearly good or bad differ from country to country but the approach has been generally acceptable, as demonstrated by its use by the International Standards Organization (ISO).

<sup>1</sup> S. Yaniv and D. Flynn, *Noise Criteria for Buildings: A Critical Review* (Washington, D.C., 1968).



Although STC curves are routinely used by architects and manufacturers to rate the acoustical properties of partitions used in buildings, the adequacy of these curves from the standpoint of occupant acceptance has seldom been examined. One study designed to serve this function was recently completed.

The insulation curves of walls were simulated by Rademacher (acoustician) and Venze by means of electrical filters. Experiments were performed in a room similar to a normal dwelling room in volume and acoustics. Subjects listened to insulation simulation sounds attenuated by the network and adjusted noise levels

1/3-octave band wide centered at 1000 Hz until the two sounds were equally "loud." The "source" sounds were male and female speech, music, and random noise. The results of the subjective assessments were then compared with physical measurements of the sounds.

In a study of the acoustical rating schemes now in widespread use, D. Clark (acoustician) used a paired comparison technique in measuring noise. (He used an **anechoic chamber** as a test environment and introduced sounds by means of a loudspeaker system.) Two sounds prerecorded on

tape were presented repeatedly to experimental subjects who were given instructions to adjust one sound until it was equally as annoying as the other one. The sounds adjusted by the subjects were 1/3- or one-octave band of noise, while the standard sounds were produced at a preselected STC level. Subjects also adjusted sounds judged to be equivalent in annoyance to a family of **transmission loss** (TL) values. The results indicated that the present STC rating system is: *A good choice in rating the acoustical performance of walls, but is overconservative in rating changes in a TL curve.*<sup>2</sup>

## FHA Recommended Sound Insulation Criteria

Sound Transmission Loss (dB)

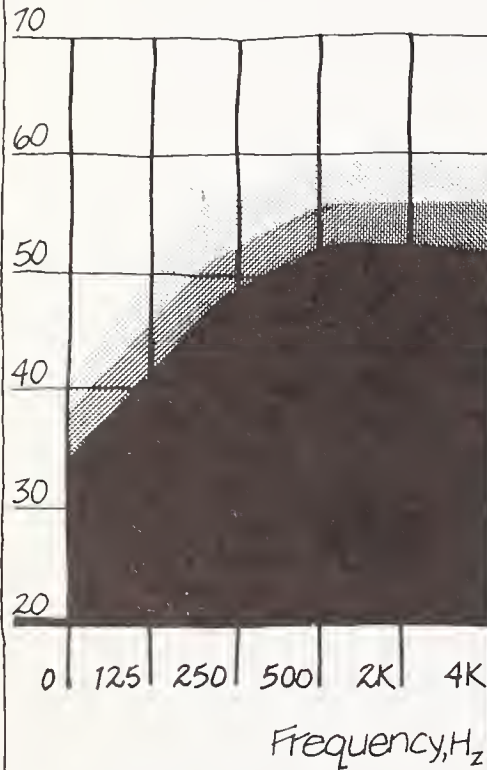

### Airborne

Grade I STC = 55  
 Grade II STC = 52  
 Grade III STC = 48

STC: Sound Transmission Class

Impact Sound Pressure Level (dB)

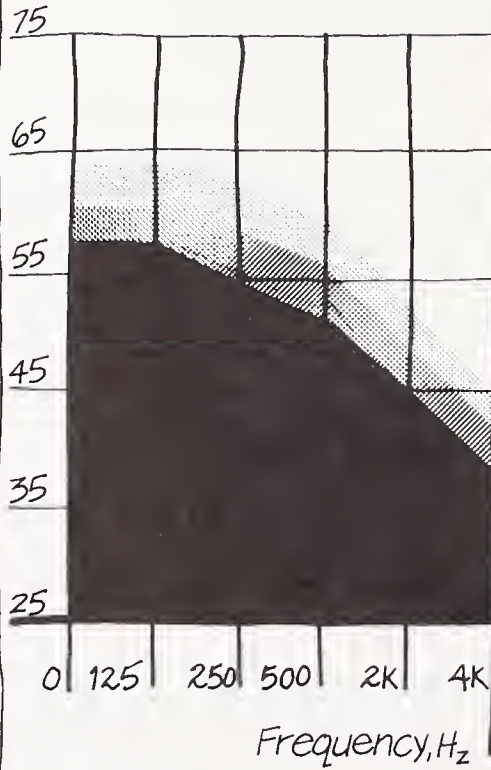

### Impact

Grade III IIC = 48  
 Grade II IIC = 52  
 Grade I IIC = 55

IIC: Impact Insulation Class

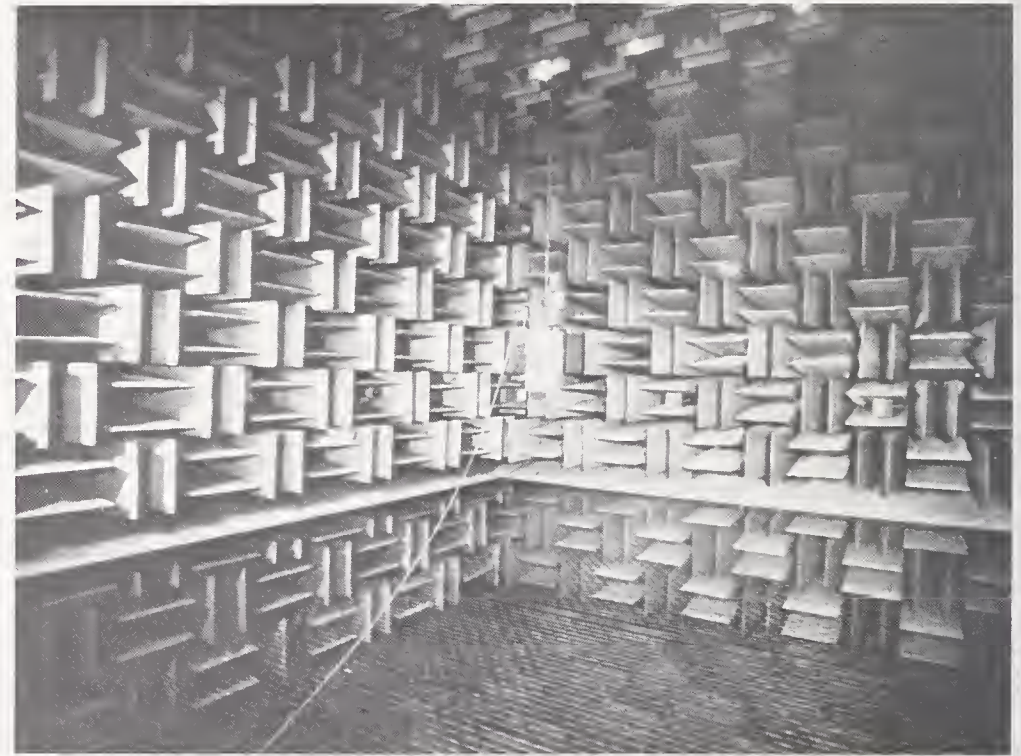

Anechoic Chamber (NBS)

<sup>2</sup> D. M. Clark, "Subjective Study of the Sound-Transmission Class System for Rating Building Partitions," *Journal of the Acoustical Society of America*, 47 (1970).



## Auditory Privacy

Another auditory problem in buildings (especially homes) concerns privacy rather than noise. In multi-family buildings, lack of acoustical privacy is a major source of irritation. Acoustical privacy can be defined as the expectation that sounds generated within the household will not be broadcast to other households in the building. This problem deserves special attention because of the widespread use of lightweight construction techniques in buildings. If this trend continues (without modification of the sound insulating properties), future homes will have far less acoustical privacy than in the past.

W. Cavanaugh et al. (acousticians and psychologists) conducted a study to explore the need for privacy in offices. The experiments took place in a test room which simulated a private office. The test subjects were provided with a desk, a chair and reading material. Noise, approximating a spectrum of an NC-35 contour, served as background while speech signals were transmitted over another sound system. The speech signals were gradually increased in intensity. The subjects were asked to judge the privacy that was required when sensitive or confidential work was being performed. The subject responded by pressing a button, after which the speech level was lowered until it could no longer be heard. In the study, the authors caution that, *The use of average TL values as the sole parameter*

*in designing for speech privacy can lead to grossly inaccurate results,*<sup>3</sup> despite the general findings that a close relationship exists between judgments of speech privacy and intelligibility of intruding speech sounds. (Occasional intruding speech sounds were judged to be quite annoying by subjects.)

A field study of the effects of noise on people at home was performed by S. Fidell et al. (psychoacousticians). The investigators equipped experimental subjects with a signaling device to be worn on their wrists at home. The device was used to indicate when a noise bothered them, and also the degree to which it was annoying. In conjunction with the rating, tape recordings were made of the sounds creating the noise, and the subjects were asked to state what they were doing when the disturbance occurred. Acoustical measurements were made in parallel with the other data collection activities. The authors concluded that the procedure described was feasible for use in community noise surveys. People participated willingly, although their normal activities were somewhat disrupted.

<sup>3</sup> W. Cavanaugh et al., "Speech Privacy in Buildings," *Journal of the Acoustical Society of America*, 36(1962).

## Speech

A major factor which influences the acceptability of the auditory environment is the ease (or difficulty) with which speech can be understood. When we consider how many activities performed in buildings are completely or partially based on the spoken word, it is not surprising that auditory criteria are influenced by speech communication attributes. The close relationship between auditory criteria and speech factors is evidenced by the work of Beranek, (mentioned earlier) in the development of NC criteria, where the ability to conduct conversations was an important determinant of the auditory quality of a space. In fact, the NC curves evolved from an early study by the same author which was focused on the problem of speech communication. This work led to the development of a set of curves, speech criterion (SC) curves, to indicate different levels of speech interference produced by noise. (The SC curves, like the NC curves, were based on attitude surveys of military and civilian office workers.)

The evaluation of an environment regarding its acceptability for speech communication has primarily been based on one or more of three factors: (1) A commonly accepted definition of an acceptable speech environment by speaker and listener. (2) The vocal sound level exerted by speakers as a function of frequency and time. (3) The degree of speech recognition measured in the presence of noise, i.e., speech intelligibility tests.

The remainder of our discussion will be devoted to a brief explanation of the methods noted above.

*A commonly accepted definition of an acceptable speech environment.* Obviously, this approach is a highly subjective one, which is not amenable to research. We will therefore not pursue it any further.

*Vocal sound level exerted by speakers.* Considerable work has been performed to estimate the extent to which noise will interfere with speech communication. The **articulation index (AI)** is such a procedure. It is an estimate of the proportion of the normal speech signal available to a listener for conveying speech intelligibility in the presence of noise.

### Articulation Index Three Types of Material

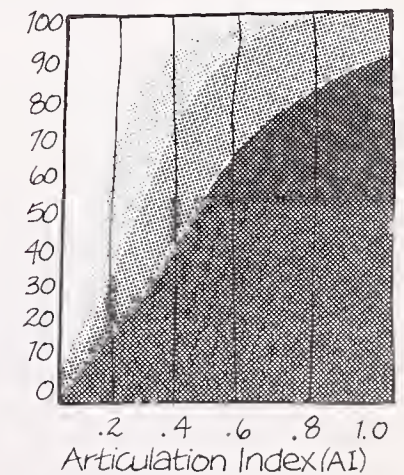

sentences known to listeners  
rhyme tests  
nonsense syllables



The AI is based on the fact that speech can be analyzed into a finite number of sounds which differ from one another in terms of their total sound level, duration of build-up and decay, and the distribution of sound level with respect to frequency. For example, the vowels as a group carry relatively large amounts of energy, distributed into harmonics of the fundamental frequency of the voice. These harmonics have distinguishable frequency regions which differ for each vowel. The consonants, on the other hand, carry much less energy, but the little energy that they do carry is found in higher frequency regions than the vowels and over shorter durations.

The frequency range of speech extends from 100 to 6000 Hz. However, most of the information contained in speech is carried by the consonants, which, because they carry little energy, are easily masked.

As one speaks, the various basic sounds are combined into orderly sequences of phonemes to form syllables, which themselves are arranged into words and sentences. The result is an acoustical signal which undergoes rapid fluctuations with respect to sound level and frequency. In order for a listener to understand speech he must be able not only to detect the various sounds, but also to integrate and recognize the constantly shifting patterns.

### Typical R.M.S.\* Pressure Levels of the Fundamental Speech Sounds (Van Cott)

Key word	Sound**	Pressure level (dB)
talk	o'	28.2
top	a	27.8
ton	o	27.0
tap	a'	26.9
tone	o	26.7
took	u	26.6
tape	a	25.7
ten	e	25.4
tool	u	25.0
tip	i	24.1
team	e	23.4
err	r	23.2
let	l	20.0
shot	sh	19.0
ring	ng	18.6
me	m	17.2
chat	ch	16.2
jot	j	13.6
azure	zh	13.0
zip	z	12.0
sit	s	12.0
tap	t	11.7
get	g	11.7
kit	k	11.1
vat	v	10.8
that	th	10.4
bat	b	8.0
dot	d	8.0
pat	p	7.7
for	f	7.0
thin	th	0

\*Root Mean Square

\*\*Spoken by a male adult at a normal level of effort.

When noise is present, some of the sounds and their shifting patterns are lost, and the speech becomes more difficult to interpret. As a result, speech intelligibility deteriorates in proportion to the sound level and bandwidth of the noise relative to those of the speech signal.

*Speech intelligibility tests.* While the research basis for relating the physical power of speech components to intelligibility (the AI) is rather tenuous, and that associated with a commonly accepted definition of acceptability is non-existent, evaluation based on speech recognition has resulted in a comprehensive body of research-based information.

Speech intelligibility research is designed to provide information concerned with the effect of noise on the understanding of speech. The general approach employed is to transmit various types of verbal material (e.g., words, sentences) in the presence of noise, and determine how many, or what proportion, of the "messages" transmitted, are accurately received by a listener. This information is then used to predict the speech intelligibility of an environment or a communication system. The procedure was first developed to evaluate radio systems for military use, e.g., air to ground. One of the goals in the early research was to eliminate high and low frequencies in radio transmission to enable a maximum number of messages to be sent over a given bandwidth, without a serious loss in intelligibility. For example, the telephone uses a rather

narrow frequency range which results in some loss of quality without compromising the amount of speech information transmitted.

*Language and intelligibility tests.* Obviously, the function of speech is to convey information. Therefore, the evaluation of an environment from the standpoint of speech intelligibility must take into account the fact the information being transmitted may vary considerably in terms of difficulty. Defining the informational content of language has been pursued by many researchers, engineers, mathematicians, linguists, psychologists, and others. While a treatment of this rich research topic is beyond the scope of the present work, it is necessary to mention a few factors related to the subject in order to gain an understanding of how speech intelligibility tests are designed and used.

The speech intelligibility or articulation test is a standardized procedure for determining the probability that a message will be understood during adverse conditions of communication. In such tests, speech communication is simply represented as a series of message units (test items) selected according to certain rules from a set of such units, e.g., words of one syllable such as go, to, car, etc.



These message units are spoken in a well-defined sequence by a speaker to a listener, and the listener records responses after the presentation of each test item (in laboratory tests, tape recordings often are used). The message unit is usually preceded by a statement such as *you will write*. A test score is computed by determining the proportion of correct answers to the total items on a test. Tests are often comprised of 50 items, with each correct one being worth 2 points.

Word tests have been constructed at many levels of difficulty, in accordance with specific requirements. Typically, early tests were comprised of **phonetically balanced (PB)** single syllable words. The words were selected from a compilation of such words most often used in publications. The final test (20 lists of 50 words each) was constructed so the phonetic sounds in the test appeared with a frequency equal to their frequency of occurrence in the English language. For example, the sound "S" appeared much more frequently than the sound "Z." While PB tests of common words serve many functions, they are not sufficiently sensitive for evaluating spaces or communications systems requiring superior performance, e.g., an auditorium or lecture room. Consequently, other lists were developed to make more refined measures. One such approach employs "nonsense" syllables. They are constructed by randomly combining consonant-vowel-consonant combinations which do not include words

of the English language (e.g., MEEP, NAM, NOOTH, etc.). Test scores using nonsense syllables as expected are far below those based on the intelligibility of common words. PB word tests and nonsense syllables are but two approaches to evaluate speech intelligibility. Other tests used for this purpose employ sentences, rhymes and, phrases.

### Phonetically Balanced (PB) Word List

- |            |            |            |
|------------|------------|------------|
| 1. gill    | 18. ways   | 35. hock   |
| 2. suck    | 19. wish   | 36. niece  |
| 3. perk    | 20. pit    | 37. tan    |
| 4. fate    | 21. cloud  | 38. vast   |
| 5. five    | 22. scythe | 39. our    |
| 6. need    | 23. blush  | 40. start  |
| 7. pick    | 24. shoe   | 41. bounce |
| 8. log     | 25. snuff  | 42. bud    |
| 9. nab     | 26. moose  | 43. frog   |
| 10. else   | 27. mute   | 44. quart  |
| 11. gloss  | 28. rib    | 45. rap    |
| 12. hire   | 29. awe    | 46. charge |
| 13. bought | 30. trash  | 47. sludge |
| 14. dab    | 31. corpse | 48. tang   |
| 15. earl   | 32. bait   | 49. them   |
| 16. bean   | 33. job    | 50. vamp   |
| 17. nut    | 34. hit    |            |

### Modified Rhyme Test (MRT)

- |     |       |       |      |       |
|-----|-------|-------|------|-------|
| 1.  | sing  | sit   | took | shook |
|     | sin   | still | cook | took  |
|     | sip   | sick  | hook | book  |
| 6.  | fin   | fig   | toil | boil  |
|     | fit   | fib   | foil | soil  |
|     | fill  | fizz  | coil | oil   |
| 11. | bit   | hit   | came | cape  |
|     | sit   | wit   | cane | cake  |
|     | fit   | kit   | cave | case  |
| 16. | raw   | saw   | rent | went  |
|     | paw   | thaw  | dent | sent  |
|     | jaw   | law   | tent | bent  |
| 21. | rake  | rave  | bill | hill  |
|     | ray   | raze  | fill | will  |
|     | rate  | race  | kill | till  |
| 26. | heath | heat  | sag  | sack  |
|     | heave | hear  | sat  | sass  |
|     | heal  | heap  | sap  | sad   |
| 2.  |       |       |      |       |
| 7.  |       |       |      |       |
| 12. |       |       |      |       |
| 17. |       |       |      |       |
| 22. |       |       |      |       |
| 27. |       |       |      |       |

*Message Sets.* The listener is at a disadvantage when trying to understand nonsense syllables because of unfamiliarity with the sounds (words) transmitted. The possible sounds which might appear are indefinitely large and no context for listening is possible. This type of test is an extreme case of an open set of words.

Under most listening conditions, however, a person is likely to have some idea of the kind of message being transmitted. The degree of preparation or background which a person brings to a listening activity substantially influences the ability to understand what is being said. The "possible" messages have thereby been narrowed considerably. This brings us to the **closed message set**, where the listener knows the message so well that the responses are restricted to the limited set defined as being appropriate. It is used when critical messages are transmitted. An example is a verbal message conveying safety instructions in an industrial environment. If such a message cannot be heard, then noise control procedures might be necessary to avoid accidents and ensure that people respond to emergencies appropriately. For example, if hazards are likely to take the form of (1) moving vehicles and (2) falling objects, then the safety instructions might be *clear the aisles* in the former instance, and *take cover*, in the latter situation.

The last speech assessment procedure described combines elements of the intelligibility test and a subjective evaluation by speaker and listener.

## HUD Guideline Procedure

The Department of Housing and Urban Development (HUD) in its "Noise Assessment Guideline" suggests a procedure which may be employed to assess the overall noise level of a site. The technique proposed, known as the *Walk-Away Test*, is a simplified version of a speech intelligibility test. (The procedure is useful for rough estimation only and is one of several approaches described in the publication.)

The Walk-Away Test is an optional evaluation that may be performed during any visit to the site. However, when the site's exposure to more than one source of noise is found "Normally" rather than "Clearly Acceptable," the Walk-Away Test is strongly recommended as a means of assessing the cumulative effects of noise from various sources.

The Walk-Away Test has been designed to evaluate *without reference to specific sources* the overall noise condition at a site. Since noise may vary during a 24-hour period, this test should be performed at those hours when noise is apt to be most severe (during the peak morning and afternoon traffic periods) and at those hours when noise is apt to be most annoying (i.e., between 10:00 p.m. and midnight when people are trying to go to sleep).

## The "Walk-Away" Noise Test (HUD)

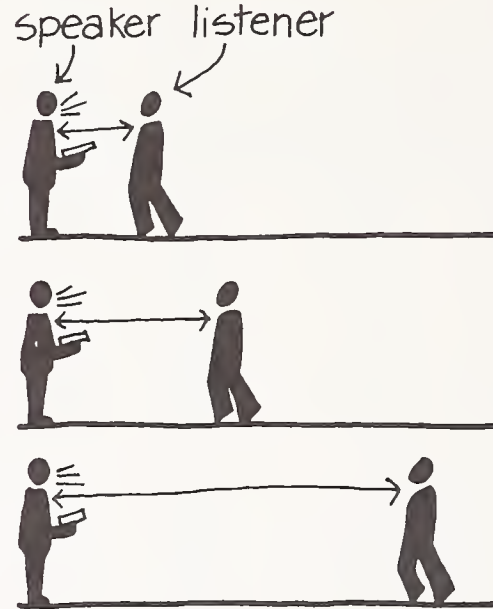

### HUD "Walkaway" Test Site Exposure to Overall Noise Levels

Distance where speech understanding is judged	Acceptability category
More than 70 ft . . .	Clearly Acceptable
26-70 ft. . . . .	Normally Acceptable
7-25 ft. . . . .	Normally Unacceptable
Less than 7 ft. . .	Clearly Unacceptable

The Walk-Away Test requires two men who exchange roles as speaker and listener; thus, each person should have normal hearing and an average voice. To perform the test, you will need a 100-ft. tape measure and some reading material with which both persons are unfamiliar.

The speaker should stand at a fixed location, while the listener, starting at a distance of 2 or 3 ft., backs slowly away. The speaker should hold the reading material at chest height in such a way as not to block the direct path from himself to the listener. He should not raise his voice in an attempt to maintain communication.

At some point the listener will find that he can understand only a scattered word or two over a period of 10 seconds or more. At this point, measure the distance between the listener and the speaker.

For consistent and accurate results, this procedure should be repeated several times during each visit and the distances should be averaged. Also, the roles of speaker and listener should be reversed to average out variations of normal speaking levels and hearing acuity. After each visit, evaluate the site's overall noise levels by using a table.

*Example: The site's exposure to both roadway and railway noise has been evaluated as Normally Acceptable. Therefore, we assess the overall noise levels during three separate weekday visits to the site. During Visit 1, made between 8:00 and 9:00 a.m., the distances where understanding just became difficult were 50 ft., 55 ft., and 54 ft. for an average of 53 ft. The average of distances for Visit 2, made between 4:00 and 5:00 p.m., was 47 ft. and for Visit 3, made between 10:00 and 11:00 p.m., was 68 ft.<sup>4</sup>*

Now that we have discussed the environment from the standpoint of speech communication, we will turn to the problem of annoyance and disturbance caused by noise. The section that follows traces the procedures used to measure the basic characteristics of sound (psychophysical procedures) and their evolution to methods used to assess the noises produced by major sources such as aircraft and motor vehicles.

<sup>4</sup> T. J. Schultz and N. M. McMahon, *HUD Noise Assessment Guidelines* (Washington, D.C., 1971).



## Loudness Level

The earliest attempts to quantify the subjective magnitude of sounds were made at the Bell Laboratories by H. Fletcher (psychoacoustician) and W. Munson. These studies were designed to define and measure loudness.

The **loudness level** of a tone was defined by Fletcher and Munson as the intensity level in dB of a tone when compared with a reference tone having the single frequency of 1000 Hz. The procedure employed in their data collection is known in psychophysics as the **method of average error**. The experimental subjects adjust the intensity level of the reference tone until it is judged as being equally as loud as the test tone. A compilation of many judgments, by a sample of subjects making these judgments with a variety of tones varying in intensity level, results in data that can be presented in the form of **equal loudness contours**.

These Fletcher-Munson curves are of special interest to both designers and acousticians, because the 30-**phon** level forms the basis for the dBA scale of sound level meters, the most commonly used measure of sound. (This curve measures the sensitivity of the average ear to broadband sound.)

Because of its importance as a noise source, a number of techniques has been developed especially to measure and evaluate aircraft noise. The man usually associated with the refinement of these measurement methods is K. Kryter (psychologist), who states that *people's attitudes toward the unwantedness of sounds are in part determined by their masking, loudness, startle, distractive and auditory fatigue effects.*<sup>5</sup> Kryter indicates that these effects are also determined by the spectral characteristics.

## Equal-loudness Contours for Pure Tones (Fletcher and Munson, 1933)

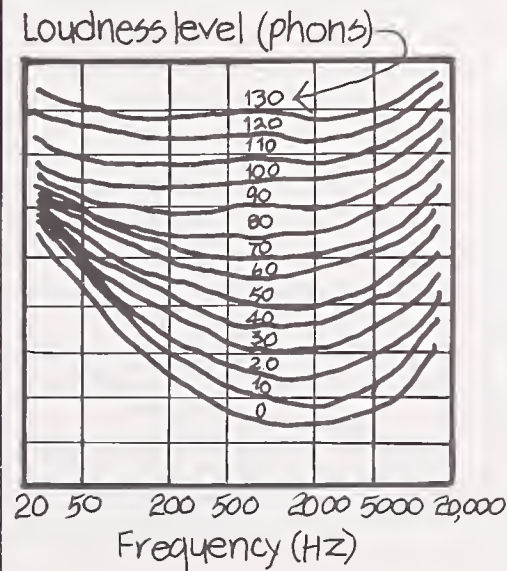

<sup>5</sup> K. Kryter, *The Effects of Noise on Man* (New York, 1970).

A major advance in methodology was introduced by S. Stevens (psychophysicist) who, while retaining the concept of equal loudness contours, developed a new methodology in defining them. Instead of confining judgments to those of equality, he had subjects also estimate magnitude.

His basic procedure was as follows: a standard tone of 1000 Hz at 40 dB is given the arbitrary value of 1 **son**. Subjects make adjustments of a comparison sound until, for example, it is twice as loud as the standard; this level is defined as 2 **sones**. Judgments are then made as to 1/2 the loudness of the standard; these are defined as 1/2 **son**. Further comparisons can then be made in a similar manner for 1/4 **son** and 4 **sones**, etc. Intermediate points are then computed on the basis of bisection between the empirically based data.

## Phon-Sone Relationship (Stevens)

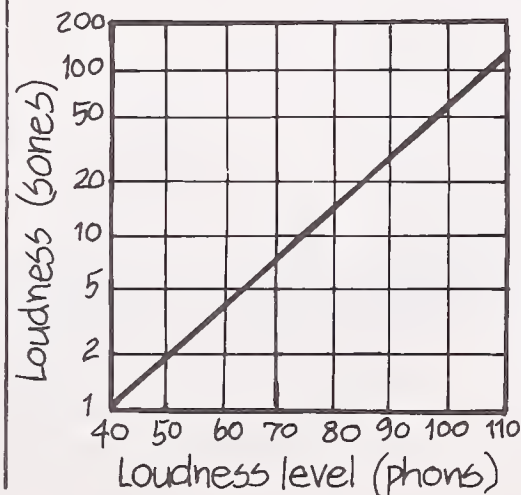

## Perceived Noisiness

A scale was developed to express **perceived noisiness (PN)** based on occurrences of sounds of equal duration. The unit of perceived noisiness is the **noy**. A sound judged to be subjectively equal in noisiness to an octave band of random noise centered at 1000 Hz and a sound pressure level of 40 dB is given a value of 1 **noy**; a sound judged as twice as noisy is 2 **noy**, etc.

The perceived noise level (PNL) was developed because loudness based judgments on complex stimuli such as aircraft noise were inadequate. PNL measures were found to be deficient too, especially for jet aircraft noise. Investigators determined that certain tonal components within the broadband noise (i.e., pure tones which could be distinguished above the general noise) and flyover duration both had to be taken into account in any evaluation procedure. PNdB was the name of the unit given to the PNL calculated for a sound. The PNdB unit is the translation of the subjective **noy** scale to a dB-like scale; an increase of 10 PNdB in a sound is equivalent to a doubling of its **noy** value.

The judged PNL of a given sound is equal numerically to the maximum overall sound pressure level of a reference sound. Complex sounds designed to simulate jet aircraft noise (with pure tone high-frequency components) have been used in studies employing similar procedures. Kryter and K. Pearson (psychoacoustician) used a method of paired comparisons to determine the subjective noisiness

of sounds consisting of a steady-state pure tone immersed in noise, and the same sound minus the pure tone. Stimuli of various frequencies, but at the same PNL, were used as standards. The comparison stimuli, similar to the standard in center frequency and bandwidth, were presented at a preselected number of levels above and below the standard.

The sounds were recorded in pairs on magnetic tape. The subjects were then asked to indicate which of the two stimuli sounded noisier, or less acceptable to them. The researchers found that pure tone components in noise contributed significantly to judgments of annoyance.

## Source Noises—Aircraft, Traffic

Aircraft noise studies have also been conducted under semirealistic conditions. One of the most painstaking investigations of this type was performed for the National Aeronautic and Space Administration (NASA). In this experiment Kryter used sounds actually produced by aircraft as they passed directly overhead after takeoff. He measured the sounds by using an octave band analysis and then had subjects make "annoyance" judgments of them. Subjects were also asked to compare the two members of a pair of recorded sounds of aircraft. The subjects adjusted the level of the "comparison" sound until it was as equally acceptable as the sound which served as the standard. The investigation verified the complexity of evaluating aircraft sounds. The findings did not indicate that simplified noise rating procedures could be readily developed.

Kryter also conducted a study using the same aircraft sounds, by the method of paired comparison. Subjects were presented with preselected pairs of sounds and were asked to judge which of the two sounds would be more disturbing if heard in the home.

The Kryter study is a good example of adapting traditional laboratory controls for use in an investigation conducted in a relatively realistic field setting (e.g., scheduled and controlled flyovers of houses, with judgments made live as well as by employing two different psychophysical methods). This approach permitted comparisons of findings using several different procedures. On the other hand, the study of Fidell et al. was designed to maximize the realism of a setting by recording and having people respond to sounds in their own environments. Unfortunately, the use of a tape recorder in such studies, while valuable from the viewpoint of a researcher, presents problems in terms of subject privacy: recording instruments, being nonselective, provide records not only of noises, but of private conversations as well. Along with aircraft noise, automotive and truck traffic noise, and to a lesser extent railroad noise, have been determined by surveys to be major sources of disturbance in buildings.

## Aircraft Flight Plan (Kryter)

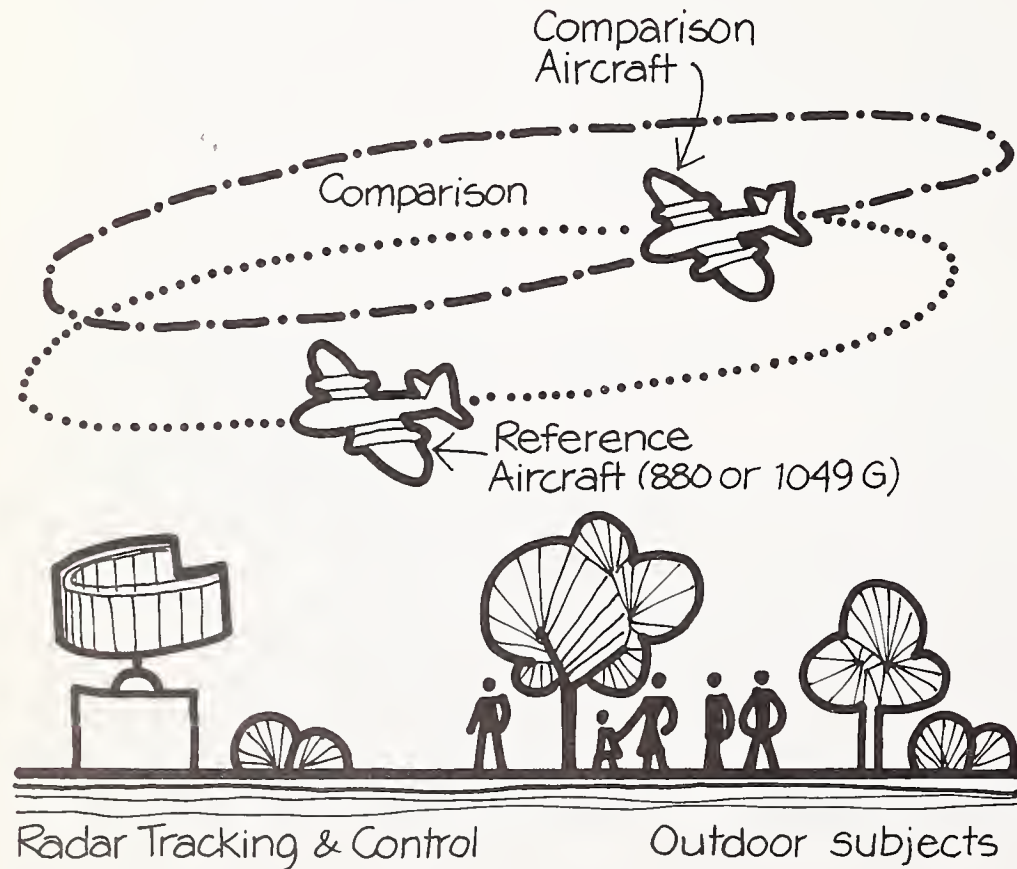



I. Griffiths (physicist) and J. Langdon (psychologist) of the British Research Establishment developed a measure of the dissatisfaction caused by roadway noise. The technique, called the **traffic noise Index (TNI)**, is based on weighted physical measurements of noise for a 24-hour period and survey data which was correlated with the roadway noise data. Computations were made of the **peak noise** levels (defined as being levels exceeded 10% of the time) and the **background noise** (defined as the

level exceeded 90% of the time). The TNI is based on a weighted combination of these values. The survey part of the study included 708 respondents from 12 sites around London, England. The locations were selected as representative of traffic flow throughout the country. The questionnaire dealt with the effect of noise on household practices such as putting children to bed and keeping windows open. Respondents were also asked to rate their dissatisfaction with noise on a 7-point scale.

## Median Dissatisfaction Percentile-Traffic Noise Index (T.N.I.)

(Griffiths and Langdon)

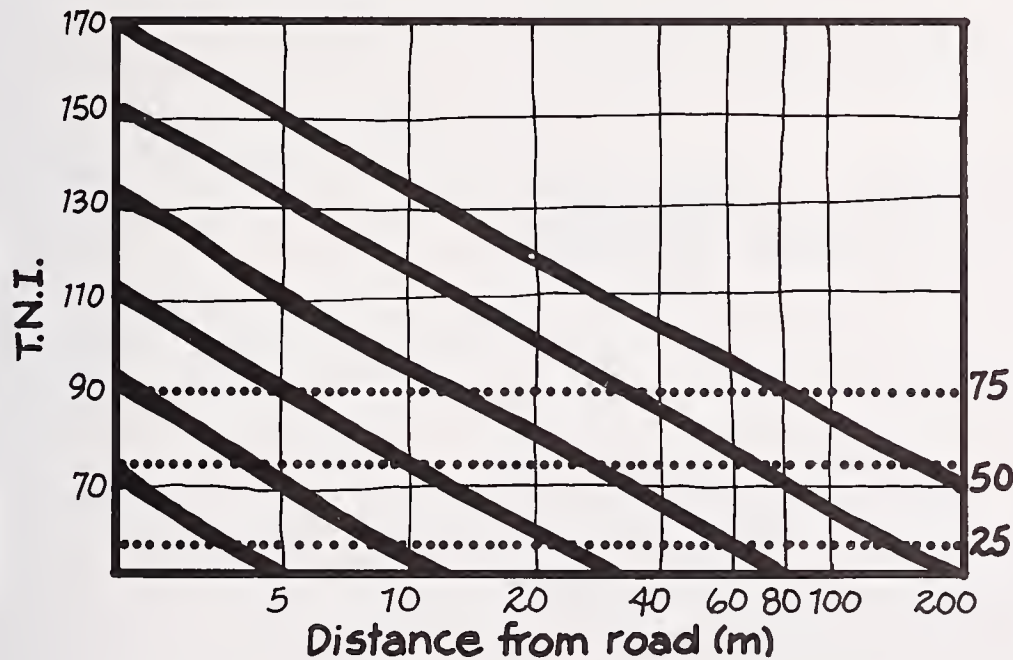

The authors found that while **average** dissatisfaction scores from many people could be correlated with physical measures of sound levels, individual reactions could not be predicted. The TNI is proposed as a viable approach to dealing with traffic noise.

The final topic on the subject of noise to be considered is that of permanent hearing damage. Many people, primarily at places of work, are exposed to sound levels which can cause a loss of hearing. Moreover, the advent of rock and roll music, often experienced at intense sound levels, also poses a potential threat to hearing, as do some activities performed at home in workshops and outdoors—e.g., cutting wood with a chain saw.

## Hearing Impairment

Hearing impairment has been studied from the standpoint of anatomical structure as well as function. Researchers, both in and outside the medical profession, have built up a substantial body of information based on detailed physiological measures in animals as well as humans. A great deal is now understood about the permanent damage caused by intense noise that has specified characteristics.

Excessive noise exposure causes a loss of hearing acuity. A temporary hearing loss in the form of a **temporary threshold shift (TTS)** can result from short-term exposure to high-level noise. A **permanent threshold shift (PTS)** can result from

either continued exposure to high-level noise or short exposure to very high-level noise. The permanent hearing damage risk associated with noise depends upon (1) the intensity and frequency distribution of the noise, (2) the duration of each individual exposure, (3) the number of individual exposures per day, (4) the number of years over which the daily exposure is repeated, and (5) the individual susceptibility to this type of damage. Noise levels of this magnitude usually occur in industrial plants and airports where employees are constantly exposed to loud noises. The temporary threshold shift is used to estimate the possible permanent damage to the ear, termed permanent threshold shift. (The relationship between TTS and PTS is a source of controversy, as are many criteria and procedures developed to clarify and quantify the effects of noise on people.)

## Temporary Threshold Shift

TTS in DB

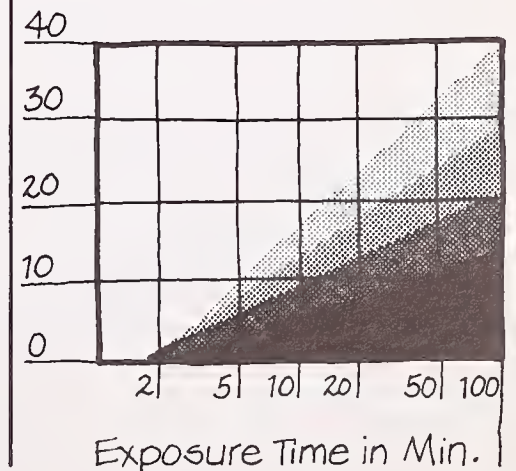

The first step in the procedure of measuring the TTS is to determine the hearing acuity of subjects before exposure to noise. An **audiogram** is taken which consists of presenting a series of tones to subjects (from 100 to 8000 Hz, usually) and determining the intensity levels required for the subjects to barely hear each tone. The subject is then exposed to noise (e.g., a 1000 Hz tone at 90 dB for 3 minutes). Following this exposure, at preselected time intervals, a series of audiograms is taken. The objective of these measures is to determine the extent to which the audiograms taken after noise exposure differ from the ones taken before. The differences in the intensities (before and after) define the temporary threshold shift. Frequently, measures are continued until the "after" audiogram attains the same shape as the "before" data. Under these circumstances the researcher wants to know how long it takes for hearing to return to "normal."

Hearing loss of a person is measured according to the lowest (weakest) sound pressure level, called the threshold, that the individual can hear. This is done with an **audiometer**, an electroacoustical instrument consisting of an electronic oscillator, attenuator, and earphone for producing sound pressure levels in the ear of the subject at various frequencies. Hearing measurements made with audiometers are thus expressed as hearing threshold levels (in dB) at various pure-tone frequencies (in Hz).

A person is recognized as having a slight hearing impairment for speech sounds whenever the average of his hearing threshold levels at 500, 1000, and 2000 Hz lies between 25 and 40 dB.

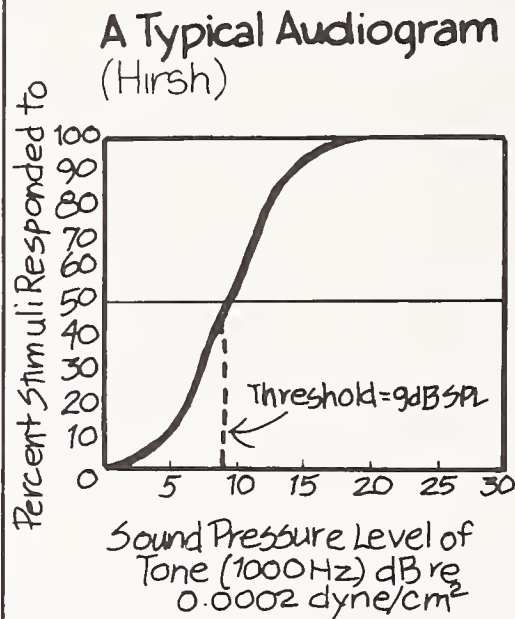

Although permanent hearing impairment is the most straightforward method of demonstrating the permanent effects of noise on man, other physiologically based measures show changes even when there is no demonstrated permanent hearing loss, e.g., changes in heart rate or blood pressure. The significance of such changes is also a source of controversy among experts.

## Damage Risk Contours

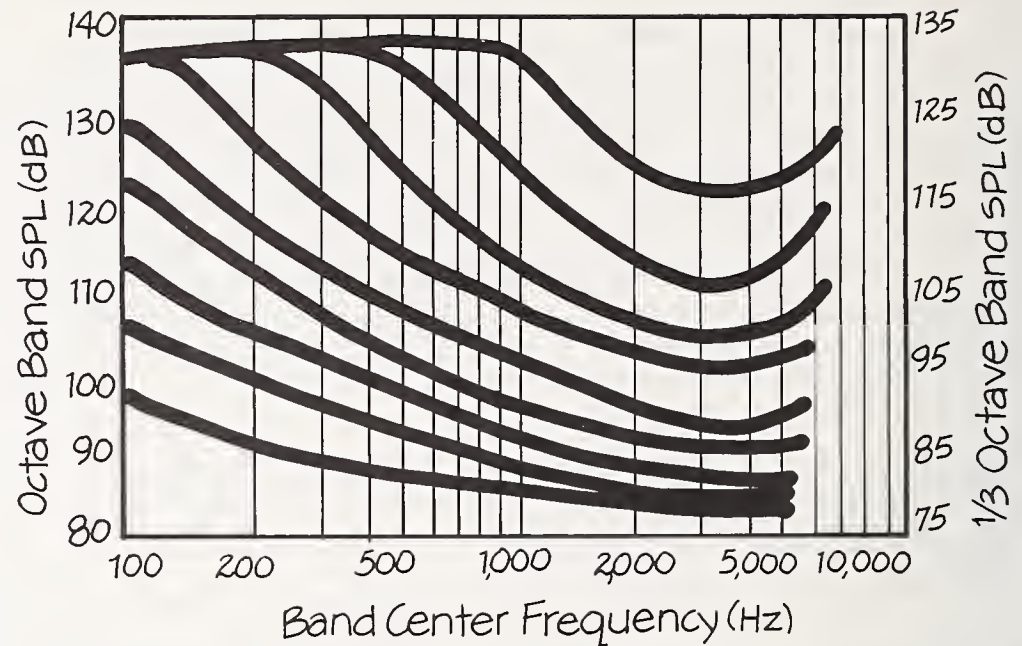

### Permissible Noise Exposures (OSHA)

Duration per day (hours)	Sound Level dBA Slow Response
8	90
6	92
4	95
3	97
2	100
1½	102
1	105
½	110
¼ or less	115

When the daily noise exposure is composed of two or more periods of noise exposure of different levels, their combined effect should be considered.



## Conclusion

One aim of the architect is to create an acoustic environment that helps occupants carry out tasks such as conducting a conversation, performing required work, etc. The design of an appropriate auditory environment depends on a number of assumptions which, though reasonable, do not appear to reflect the state-of-the-art in building acoustic research. This is because: (1) no general agreement exists on a definition of a "desirable" acoustic environment; (2) the relationship of the auditory environment to task performance is not well known (e.g., the effect of music on work production); (3) existing acoustical criteria (TL, STC and NC curves) are not based upon a solid foundation of human response data.

Research efforts have been directed toward refining physical measurement techniques. Many refinements have been made and documented in terms of instrumentation, techniques, and theory.

When we turn to the study of psychoacoustics (the response of people to sounds), however, an entirely different picture emerges. Few investigations have been directed toward evaluating existing rating schemes such as STC, TL, or NC curves which were derived from a limited number of studies employing a few people as experimental subjects. It appears as though initial studies, i.e., those "opening up" a

subject area, have been regarded as definitive requiring little additional information. We question whether existing rating schemes appropriately account for the way people respond to building noises.

The design of acoustic environments which enhance or support activities has not received much research attention. The information available dealing with the *disruption* of activities in buildings by noise is not much better. Although many problems indirectly related to noise in buildings have been investigated (e.g., speech intelligibility), comparatively few studies have been made on how people respond to noises heard in buildings except for special cases such as surveys of aircraft and traffic noise. In the latter case, little has been learned about acceptable noise levels for activities typically performed in buildings.

A communications gap exists among the many disciplines engaged in noise research. Just as a considerable language (and concept) barrier is evident between human science researchers and architects, so the acoustician and psychoacoustician have widely divergent viewpoints. The acoustician measures **sound** and refines his measurement techniques so as to best provide a physical and quantitative characterization of the sound. The effect on the person is irrelevant, once the focus of concern is sound.

The psychoacoustician, on the other hand, may never for a moment forget that the central research

concern is on the *person*. There is no **noise** unless and until the individual defines a sound as being *unwanted*. This generally accepted definition of noise (unwanted sound) forms the basis of noise research in psychoacoustics. Once the question is asked (and answered) as to *why* the sound is unwanted, the psychoacoustician finds himself with the same concern as the architect—namely the disruption of activities.

The architect who poses a question as to whether a dBA level of 75 from traffic noise is equivalent to the same level of noise from an air conditioner cannot find an answer from published sources.

One reason for the development of so many acoustical measurement schemes is the failure of carefully developed laboratory methods of measurement to meet the needs of those concerned with day-to-day noise problems. These measurement approaches, in both acoustics and psychoacoustics, were primarily based upon analytical procedures. Experimental sounds were *simple* rather than *complex*, *smooth* rather than *rough*, the onset (and termination) of sounds was *gradual* as compared with *sudden*. In short, the sounds typically used were designed to meet experimental, theoretical, and instrumental requirements at the expense of realism. Pure tones and **white noise** (an equal distribution of energy throughout a wide range of frequencies) were used as experimental material for psychologists and acousticians, although they are rarely if ever found in the real world.

The architect must deal with the noises that exist in the environment, not those produced for laboratory studies. Noise sources which have been the cause of occupant complaints are not simple and smooth at all. The most common community noises which are disturbing are due to transportation (air, motor, railroad) and construction activities. Dishwashers, plumbing fixtures, footsteps, radio, television, doorslams, and voices are often cited as being the most disturbing sounds heard inside homes. Typewriters, telephones, and automated processing equipment often elicit complaints in offices. *None* of these sounds can readily and inexpensively be measured and analyzed.

Another reason why psychoacousticians have difficulties with sounds experienced in buildings is that many noises have a meaning component associated with them. For example, when we hear a toilet flush, considerable information is transmitted by the sound. In addition, we have certain values and associations that are brought to mind when we hear the distinctive sound of water flushing; a measure of *privacy* has also been sacrificed.

In summary, although considerable information is available to help the architect describe a suitable auditory environment, many auditory problems are not well understood and must be attacked by M/E researchers.

# A Schematic Diagram of How the Human Eye Functions

## Color Vision

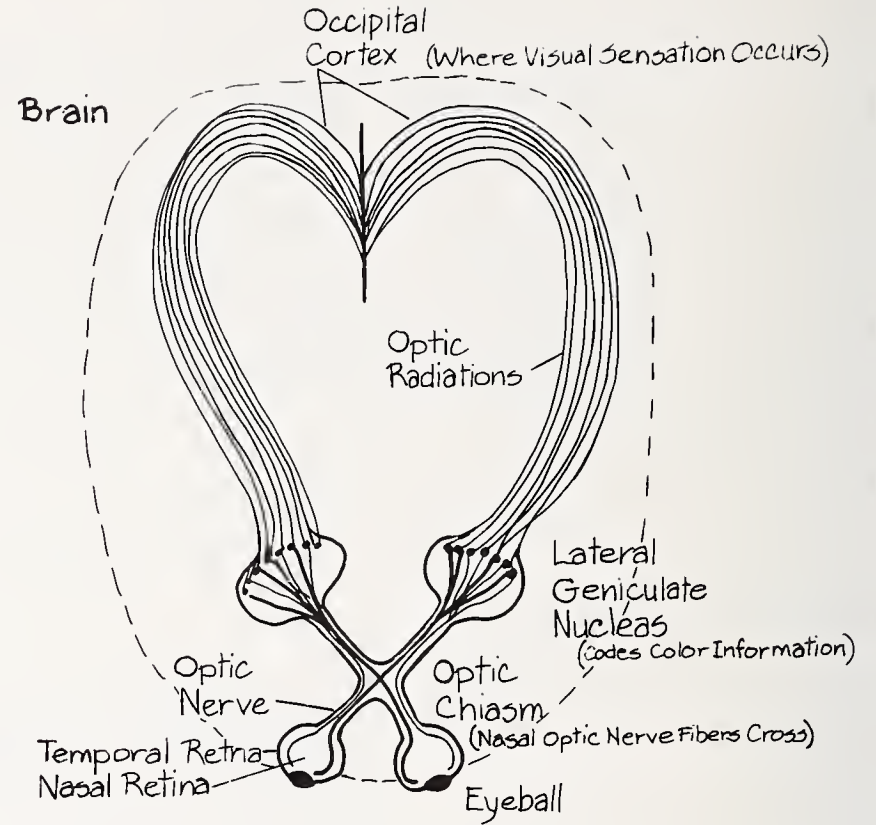
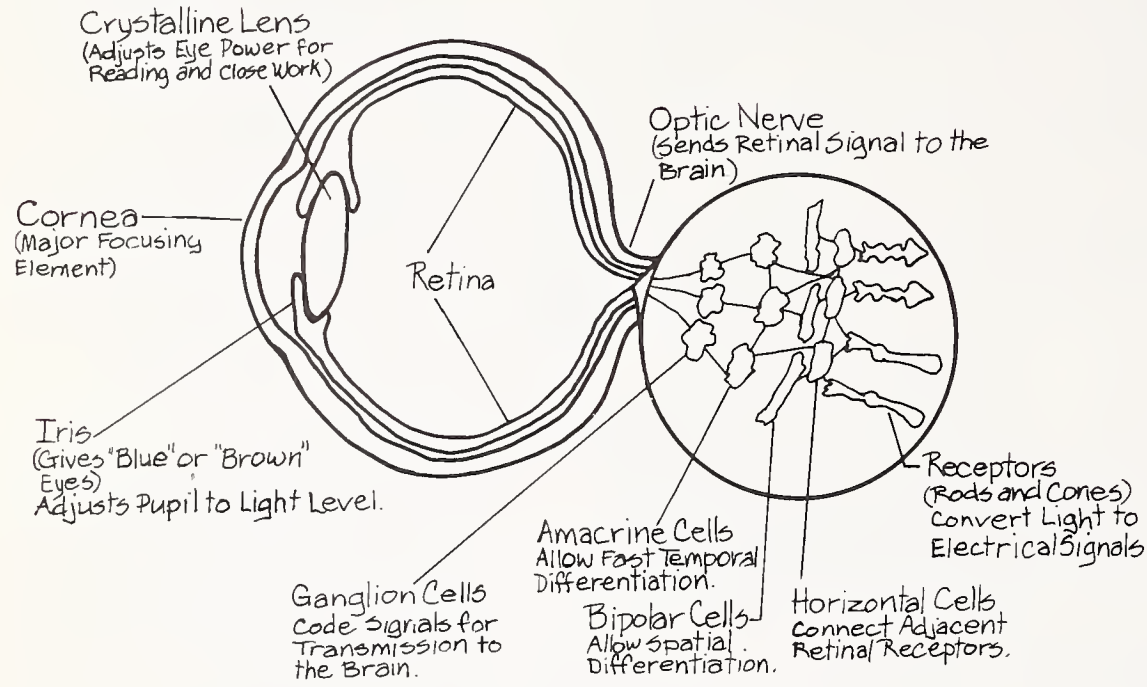



# Visual Perception

Visual Perception—Texture Gradients

Visual Distortions

The Gestalt Approach

Conclusion

Man's predominant responses to the environment—whether natural or man-made—largely depend upon the ability to see. The architect has been especially sensitive to the visual aspects of building design, as evidenced by the emphasis on the manipulation of volumes, forms and spaces—all primarily visual experiences. The focus of attention on man as a visual being is by no means limited to the design professions. Instead, there are many disciplines within both the physical and behavioral sciences which have dealt extensively with visual phenomena. As a result, it is likely that more information is available on this subject than for all of the other sense modalities (hearing, thermal comfort, odor, vibration) combined.

Man's experience with buildings is mainly visual. This view is generally supported by both architects and behavioral researchers, although for different reasons. The tradition of architecture supports the importance of visual qualities, while research findings in psychology indicate that man typically obtains more information by visual means than by all other senses. Yet, the world is not perceived accurately; what we see is not the same as that recorded by a camera.

Architects and painters for centuries have been aware and made effective use of differences between physical dimensions of the environment and the way they are perceived by

onlookers. A case in point is the “apparent” cylindrical shape of the columns of the Parthenon, despite their actual physical measurements. As J. Hochberg (psychologist) indicates:

*What we observe is never in exact correspondence with the physical situation. Some aspects are omitted, some added, some distorted. An illusion exists when observations made with the aid of physical instruments yield different results from those made without such instruments. In fact, most of the qualities of the world we do perceive (size, color, etc.) are only very loosely related to the physical measurements to which we have given the same names.<sup>1</sup>*

## Hering's Illusion of Direction

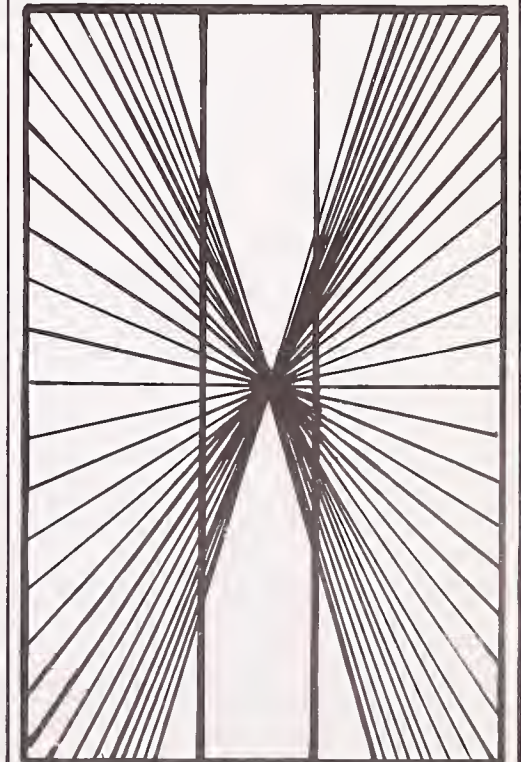

<sup>1</sup> J. E. Hochberg, *Perception* (Englewood Cliffs, N.J., 1964).

M. Luckiesh (illuminating engineer) more than a half-century ago summarized most of the characteristics of visual illusions, which have been examined by researchers since that time. In order to illustrate the self-evident relationship of such illusions to design problems, we will mention three of the examples cited by Luckiesh.

- A vertical dimension, equal to a horizontal one, appears greater.
- A space that is divided or filled generally appears to be greater than empty or undivided space.
- Characteristics of surrounds can strongly influence the perception of shapes.

Of central importance to the architect is an understanding of space perception, because of the very nature of building design. The study of space perception had two early origins: (1) the practical, technical problem of depicting three-dimensional objects in two dimensions (e.g., paintings) and (2) philosophical questions concerned with how man gains knowledge of the physical world. Many of the cues employed to depict solid objects in two dimensions were known to Leonardo da Vinci and discussed in a treatise prepared by him in the sixteenth century. Perceptual phenomena have also been examined by researchers. Several such investigations will now be discussed.

<sup>2</sup> J. J. Gibson, *The Perception of the Visual World* (Cambridge, Mass., 1950).

<sup>3</sup> Gibson

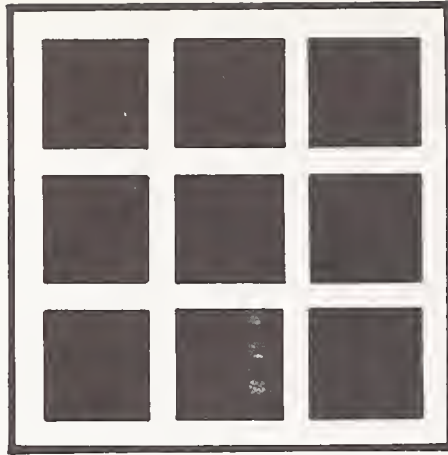

An effect of brightness-contrast. Note the darkening of the intersections of the white strips.

### Visual Perception—Texture Gradients

A comprehensive theory of space perception was developed by J. Gibson (psychologist) who described his approach in the following way:

*The elementary impressions of a visual world are those of surface and edge ... the impression of a continuous surface may account for visual space conceived as a background. The impressions of an edge may account for an outline or figure against the background—the "figure-ground phenomenon"—and together with the surface enclosed may account for the perception of an object.*<sup>2</sup>

Gibson's work was designed to illustrate the importance of texture gradients in visual and space perception. In his words, *gradient means nothing more complex than an increase or decrease of something along a given axis or dimension . . . the gradient of texture is a function of the slant of a*

### Bisection Illusion

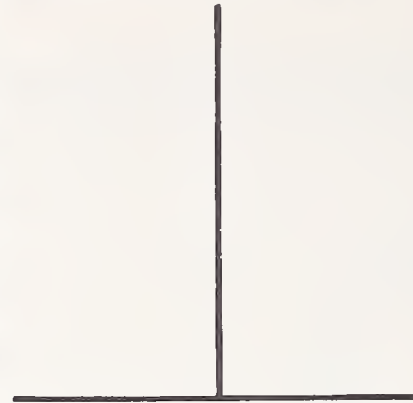

Vertical Line and Horizontal Line are Equal in Length

*physical surface away from an observer and the density of texture varies with physical distance.*<sup>3</sup>

Gibson traces his interest in visual perception to problems encountered at the start of World War II. At that time there were no instruments which could assist pilots in estimating distances from their aircraft to the ground. Research was undertaken to identify distance perception cues using a stereoscope. The procedure employed was to show points, lines or objects against a homogenous background, with the task of the subject being to estimate distances. These studies failed to provide information which was useful for training pilots. Toward the end of the war, psychologists working on this problem learned that their research methodology was inappropriate. They decided that studies of depth perception to develop landing information should be performed outdoors—in a

natural environment. Gibson then formulated a field study technique where observers were asked to judge the heights and distances of a number of wooden stakes which were planted in a level field. The stakes varied in height from 15 to 59 inches (38 to 150 cm) and were placed at a number of previously measured distances from the observers. The subjects were able to correctly judge size and distance for distances up to 1/2 mile (0.8 km).

Among the major visual characteristics indicated by Gibson as determinants of depth and distance perception are:

- *Texture Perspective.* A gradual increase in the density of the fine structure, the spots and gaps, or the extended pattern of either a part or the whole of the visual field.



Texture Perspective (NBS)



- *Size Perspective.* A decrease in the size of the shapes or figures in the visual field.
- *Linear Perspective.* This is size perspective when contours are rectilinear. It is a gradual decrease in the spacing (the size or dimension) between outlines or inlines in the visual field (man-made objects primarily).
- *Motion Perspective.* A gradual change in the rate of displacement of texture elements or contours in the visual field. The change is from motion in one direction through zero to motion in the other direction.<sup>4</sup>

Among the other perspectives mentioned by Gibson are binocular, aerial, blur, and transitions between light and shade. The last issue, concerned with the modeling of objects caused by lighting conditions, will be discussed in the next chapter which deals with the general topic of illumination.



Linear Perspective (EPA Documerica)

### Texture Gradients (Gibson)

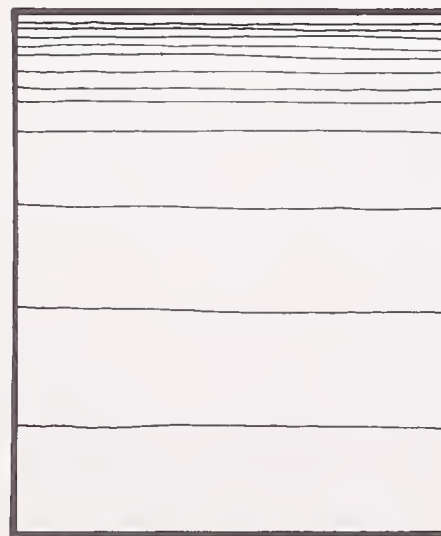
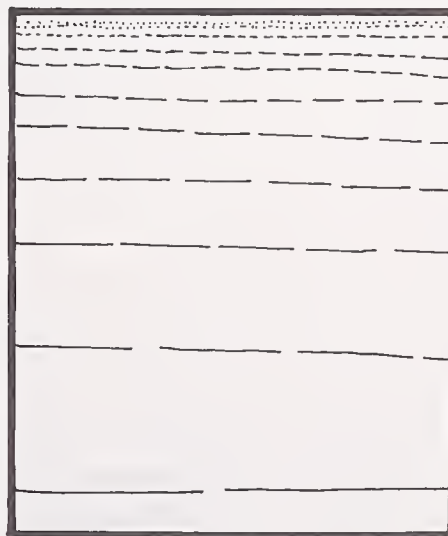
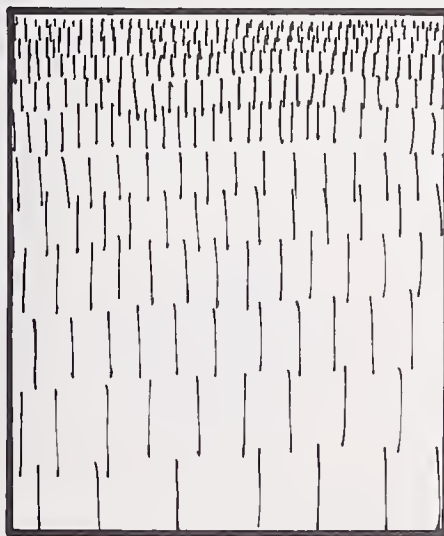

<sup>4</sup> Gibson

T. Garling (Swedish psychologist) explored the ability of observers to judge the depth and size of a space under varying viewing conditions. In the first study, observers judged the depth and size of architectural spaces out-of-doors. The observers were given the following instructions:

*This is an experiment on architectural space perception. Your task is to judge how deep spaces along this street appear, i.e., to judge the distance to the far end of each space. You will be shown spots on which you are to stand when judging the spaces. You are to assign to the first space an appropriate number to begin with. If another space appears twice as deep, use a number twice as large; if it appears half as deep, use a number half as large, and so on. In other words, assign to the spaces numbers proportional to how deep they appear to you. Try to be naive and remember it is your impression you are to report.<sup>6</sup>*

### Drawings (Gärling) Detailed:

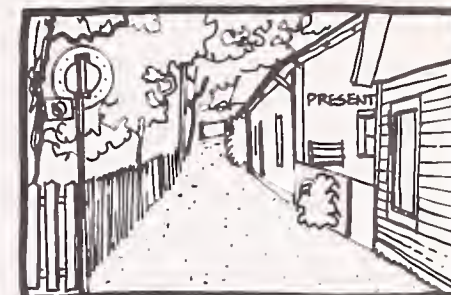

### Undetailed:

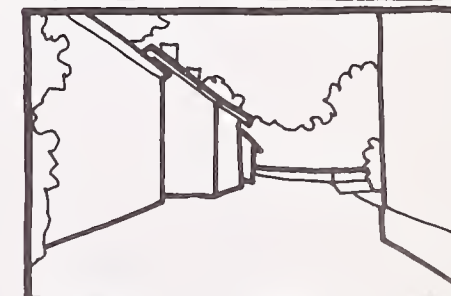
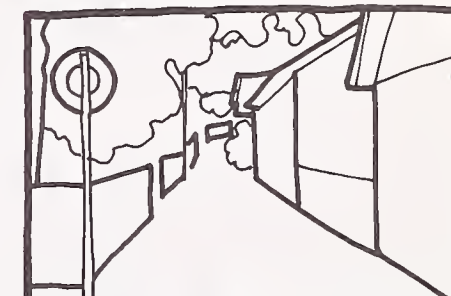

<sup>6</sup> T. Garling, "The Relation of Judged Depth to Judged Size of Space under Different Viewing Conditions," in *Experimental Studies on Architectural Perception*, S. Hesselgren (Sweden, 1971).



Garling then had 12 different observers judge color photographs of the same spaces. Observers followed the same instructions, but made the judgments monocularly, using only their preferred eye. Observers then viewed detailed perspective drawings made from the photographs. And finally, observers judged depth and size of space from undetailed or outline drawings. The last two viewings were also made monocularly. Garling's major concern was to determine the level of detail required to make accurate estimates of depth. The results indicated that the judgments were similar under all conditions.

The complexity of objects, forms, and spaces of concern in M/E studies poses a major problem for researchers. The challenge and the opportunity to provide needed information are illustrated by a relatively new research approach, eye-movement recordings.

An eye-movement camera is a system which provides a photographic record of where people look as they make observations. A series of dots and lines indicate the scanning pattern used by subjects. By this means one can follow eye movements and fixations. The places where the eye rests (fixations) are especially important because most visual information is obtained at that time. A. Yarbus (Soviet biophysicist) has made extensive studies of the eye movements made by people looking at line drawings, paintings, and sculpture.

S. Carr (urban designer) and D. Schlisser (psychologist) examined the impressions of an individual entering a city on an elevated expressway by means of eye-movement recordings. They hypothesized that (1) subjects would agree on those elements having the highest visual interest; (2) subjects would display similar orientation to the elements of visual interest; and (3) passengers would spend half their time looking away from the road.

In their study, subjects, both passengers and drivers, took an automobile trip from the suburbs to the center of the city on an elevated expressway. An eye-movement recorder, which indicated where a subject was looking and for how long, was mounted on the subject's head. From the recorded data the researchers evaluated a subject's interest in specific elements. In addition to the visual preference data obtained, the researchers also wanted to determine how well subjects remembered particular elements along the highway. Memory testing was conducted in the four following stages: (1) a pretest to determine any preconceptions the subjects might have; (2) a long interview immediately following the trip; (3) a test the day following the trip; and (4) a test 1 week after the trip.

The results indicated that subjects were likely to remember those items which were easy to name, although these usually were not the same items which attracted their visual attention. Subjects did, however, show high agreement on those items of visual interest and did tend to orient their attention in similar directions.

## Eye Movement Camera

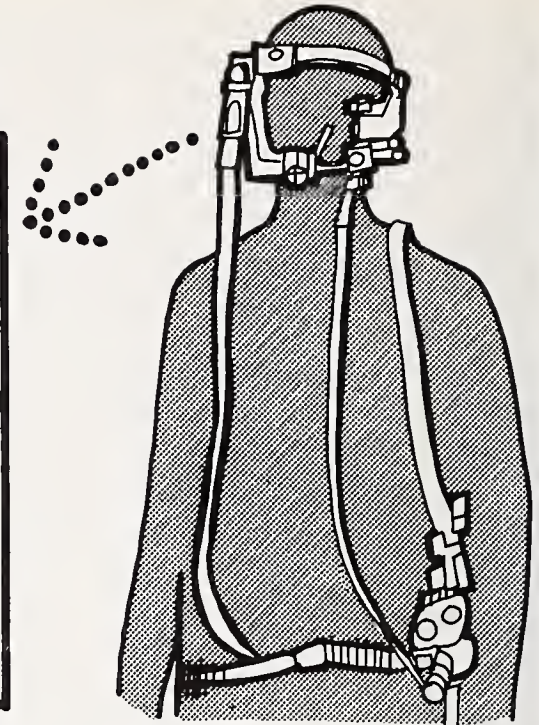
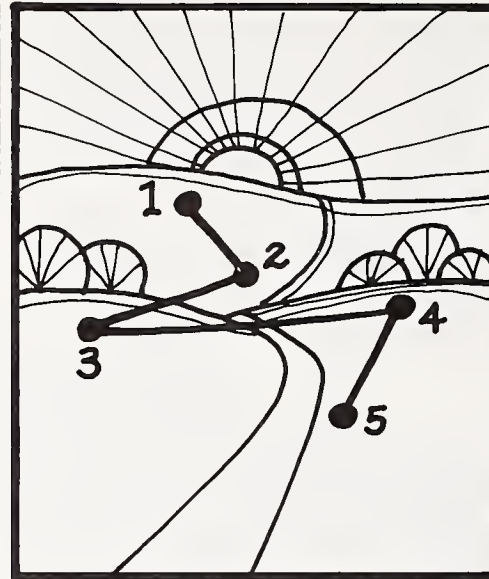

## Head-Mounted Eye-Movement Recorder (Carr & Schlisser)

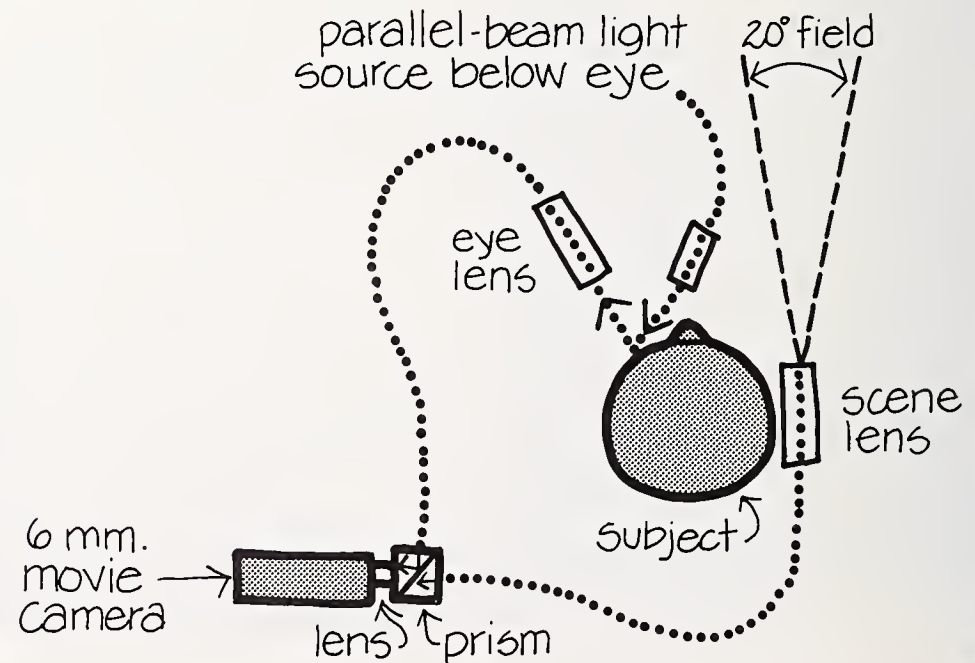



While the eye-movement camera promises to provide opportunities to assess complex environments, Yarbus cautions that many problems must be solved before the films can be interpreted properly. He indicates that eye-movement records demonstrate that people see in highly individual ways; the way that they see shows how they think. Perception is thought to be a means of gathering "essential" information from the environment, judging what is essential is largely based on experience. Simple perceptual rules are not easily found. He notes for example:

- *The brightest or darkest elements of a picture are not necessarily those which attract the eye.*
- *Color has no appreciable influence on the distribution of points of fixation.*
- *Outlines themselves have no effect on the character of eye movements.*
- *The number of details contained in an element of the picture does not determine the degree of attention attracted to this element.*<sup>7</sup>

Further, his studies were based on two-dimensional stimulus material for the most part (drawings, paintings). The building environment is much more complex.

<sup>7</sup> A. L. Yarbus, *Eye Movements and Vision* (New York, 1967).

## Visual Distortions

How do people come to perceive the world as they do? I. Kohler (psychologist) investigated the problem by having subjects fitted with special viewing devices which prevented them from seeing the world normally. By means of mirrors and prisms fitted to the eyes, subjects viewed the world backwards or upside down for weeks at a time to determine how their behavior was affected. Subjects adapted to the perceptions after a time, and had no conscious impression of distortion. After the lenses were removed, they underwent a further period of adaptation, e.g., normal viewing appeared distorted for a time.

Kohler employed one method of visually distorting the normal environment to gain a better understanding of how people perceive their environment. Another approach favored by researchers studying the same problem area is to provide conflicting environmental cues to subjects, to determine which are the most influential ones.

## Distortion Glasses (Kohler)

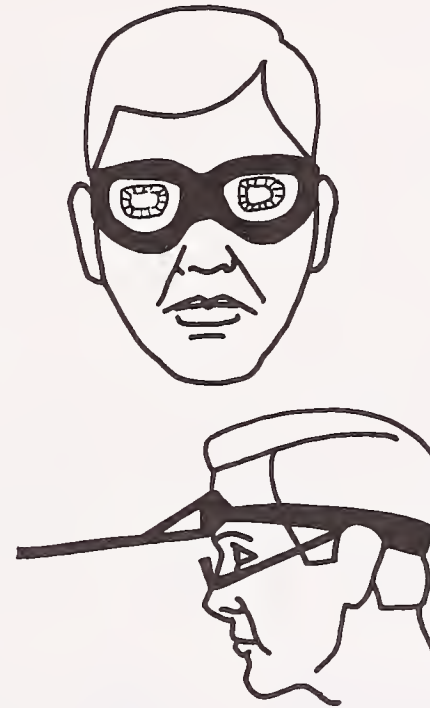

Another perceptual phenomenon, perceived size, was examined by W. Ittleson and F. Kilpatrick (perceptual psychologists). They used a distorted room to find out how people perceive their surroundings and to understand the relative importance of environmental cues. Objects and people were placed in the room and subjects judged their relative and absolute sizes. The authors indicate that relative size of the people appeared distorted because people make judgments based on past experience which tells them that rooms have expected configurations, e.g., parallel walls. Context is therefore an important determining factor in perception.

In another study, the same researchers examined the effect of size and brightness on perceived distance. They used balloons which were lighted from hidden sources in an otherwise darkened room. When the size of one balloon was larger than the other one, the larger balloon appeared to be nearer (although they were equally distant from the observer). A similar effect occurred when the relative brightnesses of the balloons were changed—the brighter balloon appeared to be nearer, although it was at a greater distance than the other one.

## Perceptual Size Contexts (Ittleson & Kilpatrick)

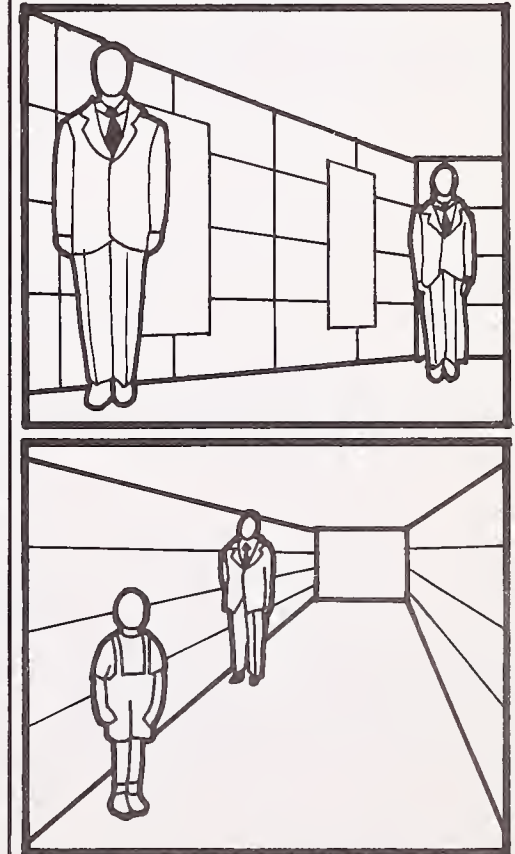

Ittleson and Kilpatrick also looked into the problem of distance perception using playing cards. Subjects were asked to estimate the distance from their position to three different playing cards. One card was of normal size, one was twice normal size and the final one was half normal size. When no other cues were present in the background, the distances were judged in accordance with size alone, although the actual viewing distances were identical.

The perception of objects in space is a major activity performed by all building users, and therefore of particular interest to us. One notable aspect of perception is that objects retain their identity despite how they are viewed. For example, when we see an object in a room such as a chair, it does not appear to increase in size when we approach it; rather, the size remains constant. Similarly, when a person wearing a black shirt moves from a shady area to the sunlight, the shirt still appears to be black (assuming no direct reflections). Features of objects therefore remain approximately constant, despite environmental and orientation changes which might be expected to alter their appearance.

Constancy phenomena were explored by researchers aware that the traditional methods of psychophysics were relatively unsuccessful when applied to many visual perception problems. The Gestalt psychology movement was thereby started.

## Constancy of Shapes

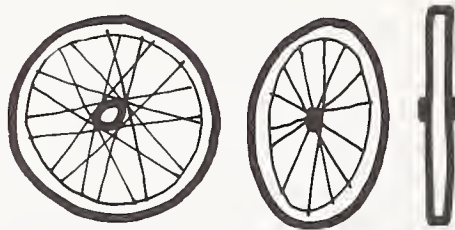
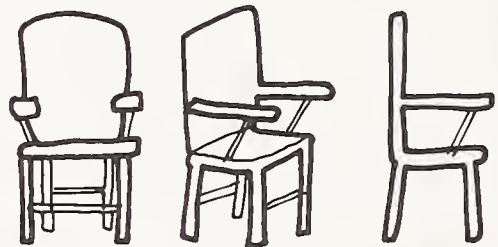
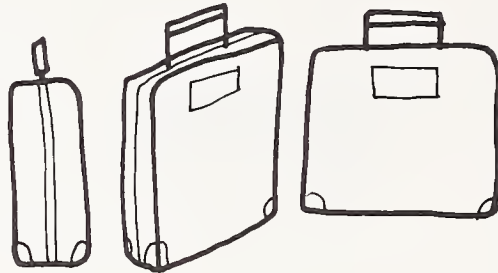

## The Gestalt Approach

*I stand at the window and see a house, trees, sky. Now on theoretical grounds I could try to count and say: "here there are ... 327 brightnesses and hues." Do I have "327"? No, I see sky, house, trees; and no one can really have these "327" as such. Furthermore, if in this strange calculation the house should have, say, 120 and the trees 90 and the sky 117, I have in any event this combination, this segregation, and not, say, 127 and 100 and 100; or 150 and 177. I see it in this particular combination, this particular segregation; and the sort of combination or segregation in which I see it is not simply up to my choice: it is almost impossible for me to see it in any desired combination that I may happen to choose. When I succeed in seeing some unusual combination, what a strange process it is. What surprise results, when, after looking at it a long time, after many attempts, I discover under the influence of a very unrealistic set that over there parts of the window frame make an N with a smooth branch ...*

*In general, if a number of stimuli is presented together, a correspondingly large number of separate "givens" does not generally occur for the human; rather there are more comprehensive givens, in a particular segregation, combination, separation.*

*Are there principles for this resulting organization? What are they? One can try to determine and isolate the factors operating here experimentally, but a simpler procedure can be used in the presentation of the most critical factors: demonstration with a few simple, characteristic cases.<sup>8</sup>*

Gestalt advocates argued that the proper subject of study is the unified whole (Gestalt) not capable of further analysis. These wholes are said to be inherently experienced by people (innate), and not the result of learning. For example, a table is perceived as a table and not something which has a top and a number of legs. What they looked for were phenomena—unbiased, free experiences which emerge instantaneously. In contrast, traditional psychophysicists used carefully trained observers to ensure that they properly respond to stimuli. The contrasting viewpoints of the two groups are further illustrated by the studies undertaken. In the case of psychophysics, the goal of a particular study is to collect data covering

a limited aspect of a general problem. The findings are then analyzed and compared with those obtained in related studies. Knowledge about a particular problem area is thereby built in slow increments.

### Gestalt Perception

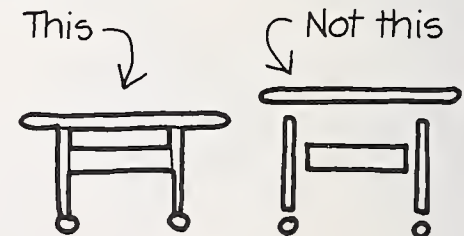

<sup>8</sup> D. C. Beardslee and M. Wertheimer, *Readings in Perception* (Princeton, 1958).



Gestalt studies on the other hand, were designed to find critical phenomena selected to discover and demonstrate general principles. The Gestalt and traditional approaches differ in terms of what subjects are asked to do, i.e., their observations.

Judgments by subjects in a Gestalt study, instead of being in the form of comparing two stimuli (e.g., to determine which of two sounds appeared louder), were in the form of experiencing (or not experiencing) a phenomenon.

The stimuli mentioned by Wertheimer are not limited in terms of scale. The groupings might be buildings, objects in a room, people, or abstract symbols. For example, he often used configurations of dots and line drawings to illustrate his points. Groupings into configurations depended on factors such as nearness, similarity, and closure.

One of the first questions addressed by Gestalt psychologists is of particular interest to M/E issues. How can we account for the perceptual experience of looking at a complex visual field (e.g., objects, situations, etc.) in which one part of it is seen as being dominant while the remainder appears as a background?

This aspect of the organization of the visual field, **figure-ground** relationships, is what concerned the early Gestalt researcher E. Rubin (Danish psychologist) who described this concept as follows:

## Gestalt Principles (Wertheimer)

### Grouping on basis of Nearness:



### Grouping on basis of Similarity:



### Closure:



To characterize the fundamental difference between figure and ground it is useful to consider the contour which is defined as the common boundary of the two fields. One can then state as a fundamental principle: when two fields have a common border, and one is seen as figure and the other as ground, the immediate perceptual experience is characterized by a shaping effect which emerges from the common border of the fields and which operates only on one field, or operates more strongly on one than on the other.<sup>9</sup>

Rubin was quite inventive and developed techniques to demonstrate figure-ground relationships in compelling ways. For example, he used cardboard cutouts of shapes—meaningful and nonsense.



Grouping of Building Features by Similar Features (NBS)

<sup>9</sup> Beardlee and Wertheimer

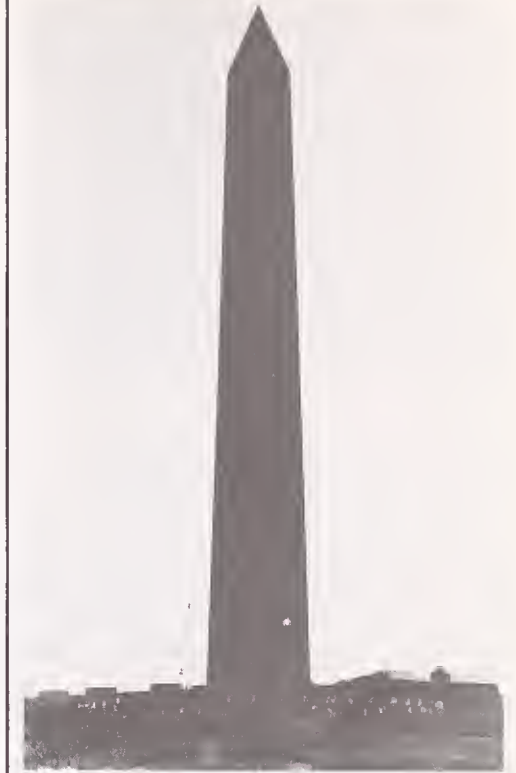

Figure—Ground (NBS)

## Reversible Images (Rubin)

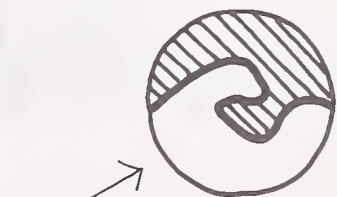

Can be seen as either:



These shapes were then held in front of a wall, thereby blocking part of the wall from view. The cardboard emerges as figure, while the wall appears as ground. When an observer attempts to see the wall as figure, he usually fails. Rubin also invented reversible images, which compellingly demonstrate the reversal of figure-ground relationships when viewed for an extended time period.

### Another Reversible Image



E.G. Boring's classic ambiguous figure, which can be seen either as a young girl or an old woman, demonstrates multiple-stable states in perceptual organization.

Wertheimer and other Gestaltists relied heavily on the concept of "good figure" as being an important criterion for determining whether phenomena, objects, etc., are readily perceived. But, how can "good" be defined in a way that is meaningful to researchers and designers?

Gestalt researchers thought that good form or quality depended upon several features. Among the most important of them are symmetry, closure, and simplicity. M. Mowatt (psychologist) conducted a study to determine how subjects judged a variety of material varied in terms of these parameters. Like Wertheimer, he used geometrical figures composed of lines, dots, and a combination of the two. Each subject was presented with each figure in random order with the instruction that it might be changed in any way to make it a "good" one, if it were not judged to be good as presented. The subjects were also instructed to give reasons for their judgments as a whole, i.e., general principles which were used. The study results indicated that closure and symmetry were considered to be good properties of a figure.

### Properties Considered "Good" by Naïve Subjects (Wertheimer)

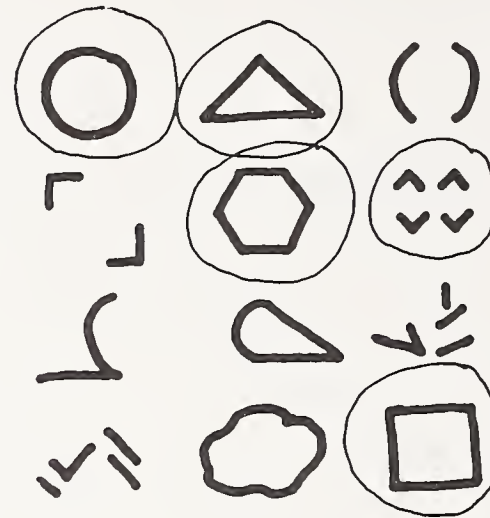

We indicated earlier that one of the interests of the Gestaltists was to explain **constancy phenomena**, i.e., why objects and their characteristics appear unchanged despite how they are viewed. Brightness and color constancy were studied by D. Katz (psychologist). His classic experiment in brightness constancy consisted of a paper disc initially half white and half black, constructed so that the proportion of white to black could be varied (target A). When the disc was spun, a uniform gray surface appeared.

Another target (B) was similarly constructed but was illuminated by direct sunlight, while target A was in the shadow of the dividing partition. The task of the subject was to adjust the gray of the right disc to match the gray on the left. Subjects were able to do this, despite the difference in illumination provided by the sunlight. The proportion of white to black in the subject's matches closely resembled the actual proportions on the test disc.

This study by Katz brings us to the subject of illumination, which will be discussed in the next chapter.

### Conclusion

We have discussed perceptual phenomena and briefly described theoretical models and research approaches developed to better understand how we perceive our environment. While Gestalt researchers and Gibson have provided insights into the general problem area, we still need to develop an orderly body of information describing the relationship of these principles to the solution of design problems. Research methods such as the eye-movement camera, while relatively new, are likely to be improved as a means to obtain more and better building user information. The work of Garling is especially significant in pointing to future research directions.



# 12

## The Visual Environment— Illumination

- Illumination Requirements—Functional and Aesthetic
- Illumination in Buildings—General
  - Quantity and Quality of Lighting
    - Quantity
    - Quality
    - Glare
    - Flicker Perception
- Lighting Measurement Methods
  - Visual Acuity Approaches
  - Suprathreshold Studies
  - Subjective Appraisals
- Conclusion

## Luminance Levels

Approximate brightness  
in ft. lamberts

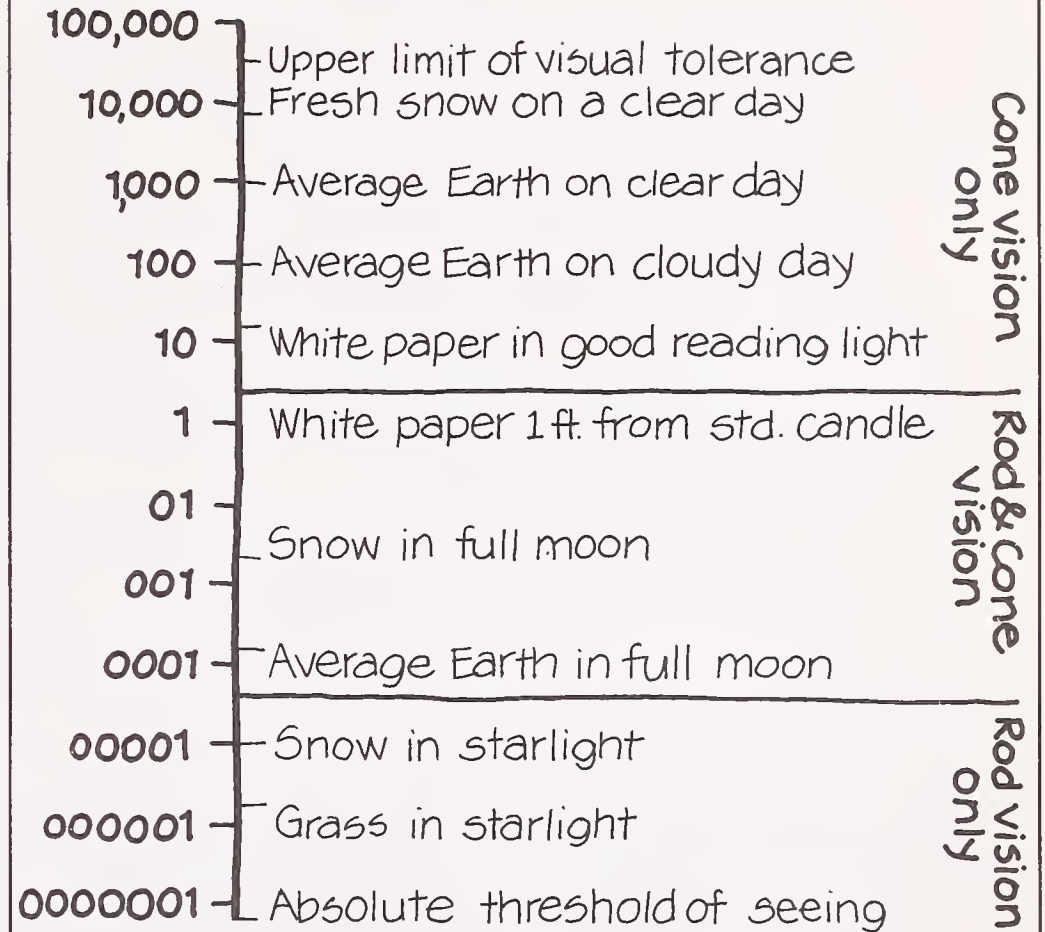

## **Illumination Requirements—Functional and Aesthetic**

High energy costs led architects and others to carefully examine current illumination practices to determine whether recommended lighting levels are appropriate. Recent research studies suggest that "more light" doesn't necessarily result in "better sight," but rather too much light can be detrimental to task performance. These investigations point to the need for using different approaches in collecting information, e.g., suprathreshold, and field studies. Lighting quality studies are receiving increased attention, primarily by researchers using semantic differential techniques.

J. Holmes (lighting engineer) summarizes the functions of lighting in buildings as follows:

*Lighting is the application of light to an object to enable us to see; it is the process of illumination, the design and control of the visual effects created by it. The sole object of lighting is to enable us to see. Full account must therefore be taken of the personal, subjective reactions of the people for whom the light is provided.<sup>1</sup>*

This definition of lighting encompasses the two major functions performed by illumination—one essentially pragmatic, and the other one concerned with aesthetics. The lighting engineer and the architect can sometimes be distinguished by their differing emphases on these two functions. For example, W. Lam (lighting consultant) and C. Crouch (research director) both addressed the topic of lighting in recent publications. An inspection of the accompanying tables indicates that each expert has a list containing several items. However, these items deal primarily with *either* aesthetic or functional considerations, with the emphasis being opposite in each listing.

Items 6, 7 and 8 of the IERI (Illuminating Engineering Research Institute) program illustrate problem areas which, although important, have frequently been overlooked. Biological investigation of the non-visible spectrum of radiant energy is a relatively new topic of interest for lighting designers. Researchers dealing with this subject have already identified important beneficial and harmful effects of radiant energy, although this disciplinary area of investigation is in its infancy.

## **Lighting for Architecture (Lam)**

- 1. Light to see by:**  
Enough light for the purpose
- 2. The light you see:**
  - Lighting for mood or atmosphere
  - Lighting for emphasis or to direct movement
  - Lighting to express intended use
  - Lighting to complement structure
  - Lighting to modify the appearance of space
- 3. The lighting system:**  
How to achieve the lighting objectives

## **IERI Research Program Categories (Crouch)**

### **Research Priorities**

1. The visual task to be illuminated
2. The veiling reflections from overhead lighting
3. Differences of brightness between task and surroundings
4. Glare: Both disability and discomfort
5. Pleasantness of total environment
6. Age of worker
7. Light and heat
8. Biological effects of wavelength of light

The interactions between light and heat have focused on determining the appropriate combination of natural and artificial illumination for optimal lighting in buildings. Deep rooms and large open spaces have for years been designed in a way where the goal was to supplement natural lighting with artificial illumination for largely aesthetic purposes, e.g., to provide the illusion in interior spaces that daylight penetrates within. A considerable amount of work has been devoted to developing appropriate mixes of daylight and Permanent Supplementary Artificial Lighting (PSALI) for designers.

Another factor noted in the IERI research listing is the *age of the worker*, which highlights the need to consider the problem of "individual differences" among people when designing lighting systems. For example, people with visual impairments (such as the aged) have different lighting requirements than those without such disorders. Such impairments are often manifested by an inability to see fine details (low visual acuity) which, like color blindness, can be traced to a physiological process. However, many features of the visual environment are judged by building occupants on the basis of likes and dislikes, i.e., preferences. These aesthetically based judgments (such as in color research) have typically demonstrated that people often disagree with one another in terms of preference.

<sup>1</sup> J. G. Holmes, *Essays on Lighting* (New York, 1974).



Thus far in our examination of illumination in buildings we have touched upon the features of lighting and the characteristics of people who require lighting. The next major interest is concerned with buildings as places which contain specific activities.

Buildings differ with respect to illumination requirements. The specification of lighting requirements becomes meaningful only when we consider the tasks (activities) performed in buildings. For example, one such hierarchical specification scheme might be as follows: a nursing home, staff offices, common spaces, and patient rooms. Uniform lighting for everyone could be wasteful from an energy use standpoint, since elderly people require more light than others. Therefore, building areas for staff personnel do not require as much light for activities to be performed as those housing patient functions, except where special requirements exist as in examination rooms.

### **Illumination in Buildings— General**

Lighting serves both a primary and secondary role in design. For example, sometimes a characteristic of light, such as sunlight, is used as an end in itself to produce an effect on building occupants. In most situations, however, lighting supports an activity, such as reading. Lighting, in this latter instance, need not be confined to practical concerns such as providing an appropriate visual environment for working. Another

lighting requirement is to enhance and highlight objects, spaces, and forms. Shadowing and modeling effects produced by lights are also frequently used to serve similar aesthetic purposes.

While all of these above functions are generally recognized as important by lighting engineers, researchers have concentrated their efforts almost exclusively on task lighting requirements and problems of lighting quality (e.g., glare). Positive attributes of light (including pleasing color characteristics) have not been ignored. Many industries and commercial enterprises have performed market research studies to determine the appropriate lighting conditions to display products (e.g., furniture, clothing, food). These investigations have dealt with specific products and as a result it is difficult to make any general statements about their findings.

Let us now consider several aspects of lighting in more detail which are of particular importance in design.

Since sources of light (radiant energy) exhibit characteristics similar to acoustical energy, we will employ a commonly used approach in acoustics to categorize lighting problems—source, path, and receiver.

To quote again from Holmes:

*We usually think of light as diffused and multidirectional, whether from the sun and sky or from luminaries and ceiling and walls. At any position in space, there is an amount of light (the total luminous flux reaching that point) and there is a flow of light (the complex of directions from which the light reaches the point). It is obvious that the effectiveness of the light in enabling us to see depends on both amount and flow. It is not enough to measure the amount of light irrespective of its directional effects; in fact, the directional effects are probably more important than the amount. When this light falls on an object, the amount is reduced by absorption, slightly for a whitish object or considerably for a dark object, and this can give us contrast on a scale from about 80% to 2%. The flow of this light is changed by reflection, refraction or diffusion, which can give us contrast in a much more delicate way and on a much wider scale. The capacity of light to reveal texture and shape is just as important as to reveal colour or shade.*

*To summarize, this mysterious element we call light is a flow of radiant power which is virtually imperceptible unless it is changed in spectral balance (colour) or in amount (absorption) or in direction (diffusion and texture) and which is invariably absorbed almost instantaneously by the objects on which it falls. When we see an object, it is because the light falling on that object is changed in direction or amount of colour by the object. Light is our means of visual perception of the whole world around us but we only use for vision less than one ten-millionth part of the power from our lamps, or even less of natural light.<sup>2</sup>*

In highly industrialized countries, especially the United States of America, daylight has been used for building illumination purposes more for aesthetic reasons than utilitarian ones. While glass office building facades are apparent throughout most major cities, these same buildings have artificial illumination sufficient to provide necessary light during evening and daylight hours, and these lights often tend to be on all day long. Daylight and sunlight are therefore used as sources of special and/or supplementary lighting.

There are occasions where light sources may be viewed directly by occupants of buildings. This outcome might result by design or accident and it might be beneficial or detrimental, depending on the particular design situation and the activities to be performed in the space. For example, in most instances we would not want the sun to be viewed directly, but at sunset when sun luminance is tolerable and the sun can be viewed directly this sight can be spectacular. Similarly, for most activities we would not anticipate that viewing a source of light would be beneficial, but a restaurant lighted by candles is readily accepted by many

<sup>2</sup> Holmes

diners for the "mood" often associated with this type of lighting.

Under most circumstances, however, lighting in buildings is designed to minimize the direct exposure of the eye to light sources in the field of view. One reason for this approach is that our visual sense is **phototropic**. That is, we tend to look at the brightest areas before us on an involuntary basis. A visible source of light would therefore distract a person from attending to anything else. Another difficulty associated with having a light source in a direct field of view is the *glare* that is produced by lights—discomfort and disability glare.

Light can undergo several kinds of changes between the source and our eyes. It may be redirected, absorbed, polarized, and diffracted (broken into spectral components). The redirection of light can occur by reflection or transmission. In either case, the light rays can be deviated in a regular manner that preserves images (as in a mirror, or through a lens); or the rays can be diffused in more or less random directions.

The particular value of light to us is that it can be changed, in color or intensity, by the objects which reflect (or transmit) the light falling on them; this is how we see objects. Generally, we see things because they absorb some of the light and transmit or reflect the remainder.

There are two different modes of differential absorption; if the power in only some of the wavelengths in the spectrum is changed by selective absorption, we see a change in color; if the intensity of the light is changed uniformly at all wavelengths by partial absorption or by a directional effect, we see a difference in contrast. (The latter occurs if the immediate surround does not change, or changes differently.)

The ultimate success (or failure) of a lighting system design is determined by how well it satisfies the requirements of the people for whom it was intended. At the very minimum, illumination must be responsive to the needs of those with normal vision. For particular buildings, such as those which are to house the visually handicapped, the specialized requirements of these occupants must also be met.

We have already mentioned one physiologically based response—phototropism—which if ignored, is likely to lead to bad lighting conditions and other problems not limited to distraction.

One potential building illumination problem is **dark adaptation**—the experience which we encounter when entering a dark theater from a bright street. Although we begin to see reasonably well within a few minutes, complete adaptation to seeing in the darkened space takes approximately 40 minutes. The reasons for taking this long are related to the fact that different visual processes are used for daytime and nighttime vision. The central part of the eye (**fovea**) is used during daytime (with **cones** as light sensitive cells) while the periphery of the eye (and **rod** cells) is used under conditions of limited lighting. In bright lights, the cones function well, but the rods are knocked out by the bleaching of their photosensitive pigment. When the bright light is replaced by dim light, the cone system does not have enough light to function, and the rod system recovers only gradually as the photopigment is regenerated.

### Dark Adaptation Levels

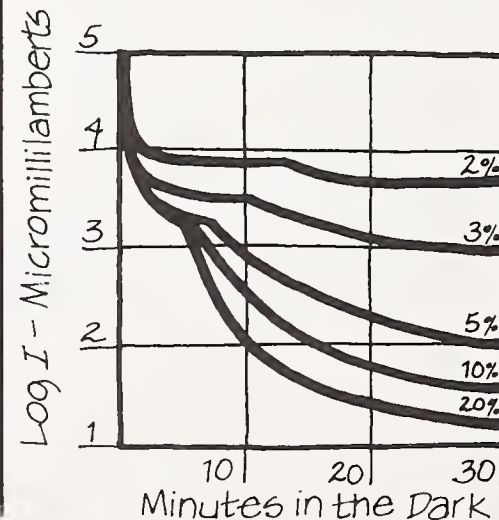

### CIE Standard Luminosity Functions

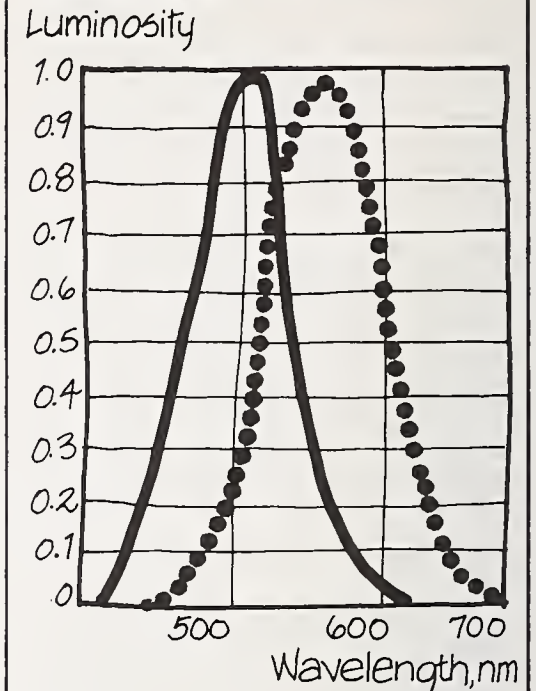

— photopic (cones)  
••••• scotopic (rods)

In the illustration mentioned above, a problem could result if an emergency occurred in the theater which is usually dark. A general power failure in these circumstances often activates an emergency lighting system of bright highly focused beams of light frequently directed more horizontally than vertically. People viewing these lights directly would quickly lose their dark adaptation and yet the illumination provided by the lights might not be sufficiently well distributed for cone vision to function optimally in all locations. Consequently, accidents and injuries might occur as occupants move toward the building exits without sufficient lighting to find their way around potential obstacles.



Dark adaptation is but one form of visual adaptation—the process by which the eye adjusts to variations in lighting levels. Another type of adjustment of the eye is **transient adaptation**. R. Boynton (psychologist) studied this phenomenon at the University of Rochester in New York. He cited an example of transient adaptation which is common to many people. Suppose that you are sitting at a desk, observing low contrast materials

*which, under the prevailing conditions of illumination, are just barely visible. Imagine that you then look through the window at the bright sky for a moment or two, and then focus down again on your task. The low-contrast details will, at least for a moment, be invisible and some time will be required before the initial level of visibility is regained.*<sup>3</sup>

In a study of lighting at the Gulbenkian Museum, J. Ribiero (architect) et al. accounted for the adaptation of the eye.

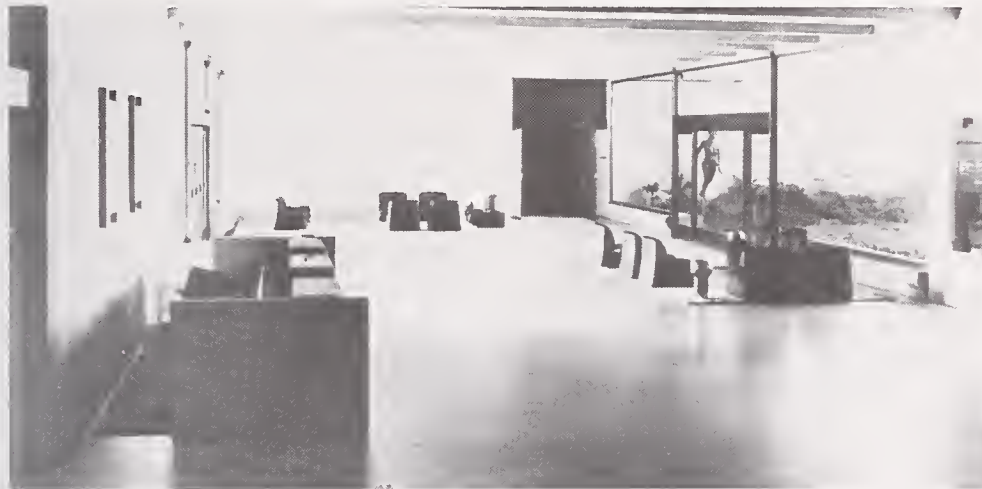

*Gulbenkian Museum—Entry Lobby (W. Allen)*



*Gulbenkian Museum—Carpet Lighting (W. Allen)*

Some exhibits must be at the lowest levels while others can be exposed to much higher levels without harm. However, if there are substantial areas of strongly contrasting brightness in the same general area, the darker areas will seem very disadvantaged and inadequate by comparison with the brighter, and since the lower illumination should not be increased, the other must be kept to a moderate level. Thus it is the requirements of the most light-sensitive objects that will tend to determine the illumination "key" for a given collection. Here it is a low key. Visitors must, however, be able to see the displays well, and if the illumination is in a low key the environment should provide ready adaptation to these low levels. This has three principal implications for design:

- (a) Adaptation from outdoor brightness to relative darkness indoors must be effected naturally and rapidly.
- (b) Changes of general brightness level from one part of the museum to another must be graduated in moderate steps.
- (c) No major part of any general view should be greatly brighter than the prevailing key.

The problems of brightness gradation were approached in the following ways.

The Museum is entered indoors from other parts of the building complex or directly from outdoors. The approach indoors takes place through a long gallery for temporary exhibitions in which the ceiling comprises simple gratings of a low reflectance, honey-colored wood, with fluorescent lamps in the space above them. The walls are of grey glass with ivory-colored sheer curtains, and the floor is the grey-green carpet of moderate brightness described earlier for the Museum itself. Spotlights can be fixed anywhere on the ceiling to light individual exhibits. The impression is of illumination at a medium key with a certain amount of sparkle.

The temporary gallery leads to the main lobby which is also the entry from outdoors, and is designed to deal with the transition problem for visitors exposed immediately previously to very bright sunshine. It is a large space with grey glass on two walls, one the entry itself and the other looking into a patio and protected by an external canopy. Visitors turn then to the right into the control and sales zone; this has no direct natural light but receives a certain amount which is diffused into it by reflection. It is a step down in brightness. One then enters the display area, either to the normal full circuit beginning with the Egyptians, or the half-circuit which comprises only the European art.

<sup>3</sup> R. M. Boynton, "Some Visual Factors in Reducing Lighting Levels," in *The Basis for Effective Management of Lighting*, ed. D. K. Ross (Washington, D.C., 1975).



The Egyptian room is "played" at a very low key, lighted only by overspill from showcases or from a few items lighted by profile lights. There is no natural light. The objects themselves are well-lighted and the room has a strong dramatic quality. Although the general key is very low, dark adaptation is effected quickly and without a sense of dissatisfaction. From this point onwards, all spaces in the Museum, with one small exception, are moderately higher in key and visitors have no sense of inadequate lighting anywhere.<sup>4</sup>



Gulbenkian Museum—Egyptian Room, Exhibit Lighting Only (W. Allen)

## Quantity and Quality of Lighting

The two most general conditions which have to be met by lighting systems are quantity and quality of the illumination provided. Most of the research performed by visual researchers interested in lighting comes under either one or the other of these headings. Let us first consider the amount of light needed to perform desired activities.

<sup>4</sup> J. S. Ribiero et al., "Lighting of the Calouste Gulbenkian Museum," *Lighting Research and Technology*, 3 (1971).

### Quantity

The trend of illumination levels recommended for buildings in the United States has been steadily upward for many years. As a consequence, these levels in the United States are now substantially higher than those employed elsewhere in the world. As long as energy resources were thought to be abundant and inexpensive, there was little reason to question the lighting practices followed for most buildings.

However, the current energy situation has led many architects, lighting designers and engineers, owners and occupants of buildings to carefully examine traditional lighting practices with a view toward using less energy for illumination. Many assumptions, such as the desirability of uniform lighting, have been questioned in the light of energy usage implications. For example, a commonly employed rationale which has led to uniformly high prescribed levels of illumination in office buildings is as follows:

- Sufficient lighting is required for the most demanding visual task to be performed, e.g., a fourth carbon which is handwritten.
- We cannot (or should not) determine in advance where this task will be performed.
- The overall lighting should be sufficient to enable the task to be performed anywhere.
- High intensity uniform lighting is therefore an appropriate lighting objective.

Such reasoning for lighting design is no longer supported by many lighting experts today. Instead, most now feel a combination of local task and overall background lighting is best.

Historically, building task lighting levels have been determined in the laboratory. The objective of the studies was to determine how well people could perform very difficult visual tasks—those which would require the discrimination of fine

details. Lighting levels are selected on the basis of threshold measurements (where the subject can barely see the stimulus) and are then adjusted upward to permit continued task performance at more comfortable lighting levels. These *threshold visual acuity* studies comprise a large proportion of the research dealing with illumination requirements in buildings. A follow-up to these procedures in recent years has been the investigation of more realistic tasks examined in the laboratory and under field conditions. An example of such a task is to determine how well people can thread a needle under a variety of illumination conditions.

An approach which differs importantly from the one based on threshold judgments is currently being developed and refined in a series of studies being conducted by G. Yonemura (psychologist). It employs **suprathreshold tasks** and requires experimental subjects to make judgments of *clarity* (how clearly something can be seen) rather than a determination of when it is barely visible. The major assumption made by the researcher in these investigations is that under most circumstances lighting designers deal with objects, forms, and spaces which can be seen without too much difficulty. The design problem is therefore translated into *how well* it can (or should) be seen.



Regardless of how measurements are made to determine task lighting requirements, it is also necessary to consider the levels of lighting which "surround" a task. Great disparities between task and background lighting would lead to problems associated with adaptation as mentioned earlier. Crouch indicates the importance of this factor when designing the lighting for any space. He notes that surroundings of the task which are too dark or too bright may be equally harmful and quotes Boynton as indicating that for near optimal results, the variations in luminance of the large surfaces in interiors from that of the task should not be greater than 3:1 for the immediate surrounds, and 10:1 for the remote surrounds. The task should never be darker than the surrounds.

### Quality

The subjective impressions made by different lighting systems were studied by J. Flynn (architect) et al. They wanted to find out if people occupying a room would show consistent preferences for lighting arrangements. They ran the study in a controlled laboratory with a number of lighting arrangements that permit significant variation in the visual character of the space without changing any of the other physical conditions.<sup>5</sup> Groups of subjects performed two tasks. First, they rated the lighting arrangement used when the room was entered. Following this, each of six different arrangements were rated separately after all six were shown briefly to familiarize the subjects with all the

## Evaluation of Lighting Arrangements (Flynn, et. al.)

### Floor Plan

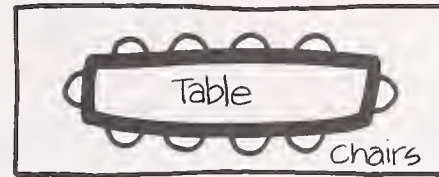

### Section 1



overhead down-lighting, low intensity

### Section 2



peripheral wall-lighting, all walls

### Section 3



overhead diffuse, low setting

### Section 4



overhead down-lighting + end walls

### Section 5



overhead diffuse, high intensity

### Section 6



overhead down-lighting + peripheral + overhead diffuse

### Arrangement 3 (.....)

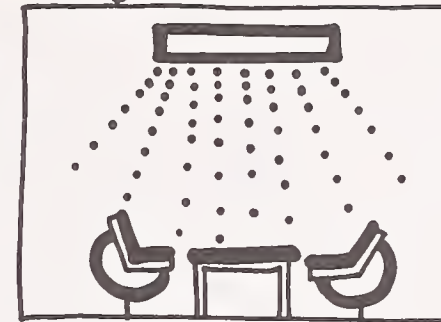

### Arrangement 6 (—)

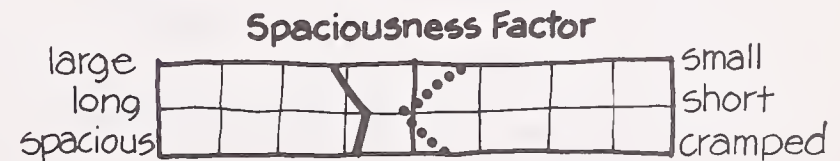
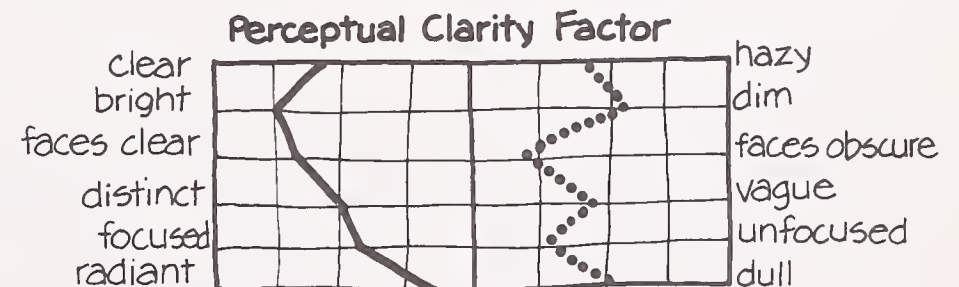
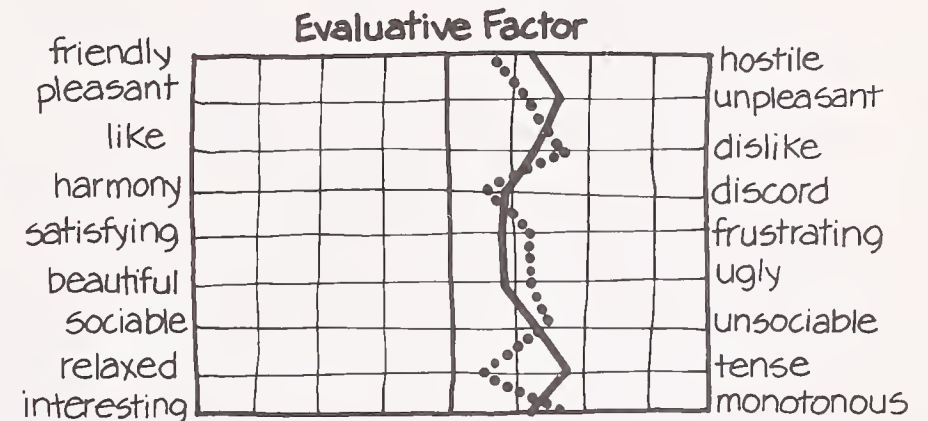
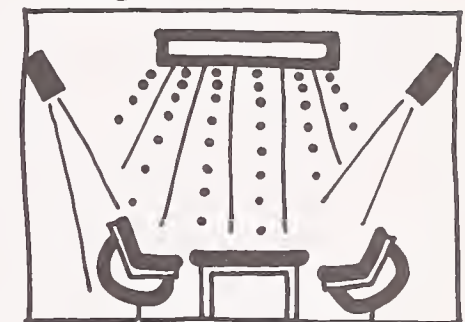

<sup>5</sup> J. E. Flynn et al., "Interim Study of Procedures for Investigating the Effect of Light on Impression and Behavior," *Journal of IES*, 3 (October 1973).

study conditions. Ratings were made by semantic differential rating scales. The authors found that the initial ratings made were similar to those obtained later, and that people responded differently to each lighting arrangement.

Research designed to examine lighting quality has been mainly to identify and eliminate bad lighting design, rather than determine the features of good illumination. The particular problem presently receiving the greatest attention is glare. Illumination engineers have dealt with two glare phenomena which have been treated as separate issues—**discomfort glare** and **disability glare**.

#### Glare

While discomfort glare is produced by physiological and/or psychological factors (not yet well-understood) which result in a painful experience, it has no particular effect on the performance of visual tasks. Disability glare, by definition, occurs when the presence of glare results in poorer task performance than occurs when no glare is present. Boynton explains disability glare as follows:

*It is caused by stray light in the eye that reaches regions of the retina remote from the primary retinal image of the glare source. Thus, in addition to the retinal images of a major glare source (e.g., automobile headlights at night), which would not by themselves present any problem, a significant amount of light is scattered across the foveal area, thereby reducing the contrast of whatever critical detail is represented there.<sup>6</sup>*

<sup>6</sup> Boynton

## Types of Glare

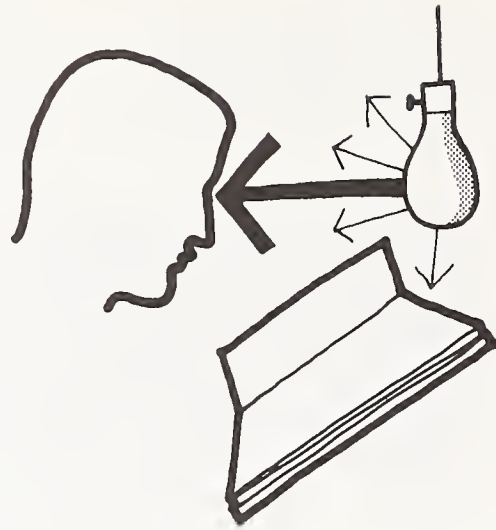

Direct Glare

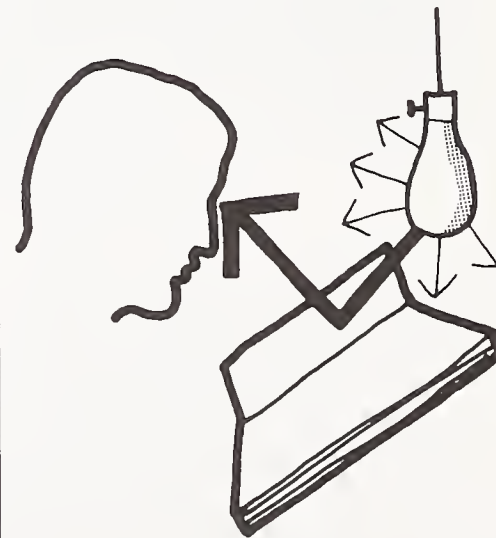

Specular Glare

Boynton, in the same paper discusses another major lighting problem:

*From the standpoint of interior lighting, especially where localized sources of illumination are concerned, there is another aspect of poor lighting quality that is more important than disability glare. This is the loss of visibility caused by specular reflections from glossy surfaces. The common example of this is the problem that arises when trying to read slick magazines, a task that becomes totally impossible if the material to be read is held at an angle that permits a virtual image of a bright source of light, seen by specular reflection, to overlay and nearly obliterate the diffusely reflecting contrast of the black type in relation to the underlying page. This is the basis for recommending that reading lamps should throw their light over the shoulder of the observer. But if one is working at a desk and the lamp is mounted on it, this geometry is almost unattainable.<sup>7</sup>*

Disability glare impairs our ability to perform tasks. The glare can be caused by a bright source directly in the field of vision or by means of reflections. Reflected glare occurs from a combination of factors associated with the characteristics of the light source, the location of the observer, the geometry of the light, and the properties of the surface being viewed.

<sup>7</sup> Boynton

H. Blackwell (psychologist) in his studies of disability glare relied heavily on a technique which produced and then used veiling reflections to establish a visibility equivalence between a practical task and the performance on a 4-minute disc task (identical to that used in his other studies). He developed a visual task evaluator (VTE) to reduce the contrast of the task by means of a veil of light until the task was just barely visible. The next step was to substitute the disc for the practical task and further reduce the contrast to absolute threshold level (defined as the level at which it can be detected 50% of the time).

In discussing problems of glare, Boynton indicates that:

*Disability glare is seldom what people are complaining about when they object to the high light levels of some modern interior lighting installations. What is complained about instead is that the bright lights are uncomfortable, that they hurt the eyes, that they result in ocular fatigue, and that they are sometimes perceived as being injurious . . . but discomfort glare is a very complex function of many variables, including the distribution of the offending elements of glare in the visual field.<sup>8</sup>*

<sup>8</sup> Boynton



The physiological basis for discomfort glare was studied by G. Fry (psychophysicist). One eye was exposed to a glare source and measurements were taken of the other eye (since both eyes work "in parallel," this procedure is feasible). Fry has found a clear relationship between judgments of discomfort glare and the pupillary action of the eye (openings and closings) required while the eye adjusts to light. He attributes the sensation of discomfort to the muscle strain associated with the movements of the iris (a diaphragm which controls the size of the pupil opening).

Discomfort glare was reviewed by O. Ostberg and P. Stone in a recent publication. The methods described (by these authors) below are indicative of the approaches that have been employed in such investigations:

*Nutting appears to be the first researcher attempting to evaluate levels of glare directly by means of systematically asking subjects for their subjective responses. The subjects were first adapted to set brightnesses, and then suddenly exposed to fields of varying brightnesses above the adaptation levels. The glare source was snapped on and off repeatedly, and its brightness was changed until the subject thought it was "just bright enough to appear glaring." The results were not analyzed in detail, but Nutting found the method promising in that the subjective assessment was quite a definite quantity and that the three observers obtained surprisingly concordant data.*

*This method of glare assessment employing production of just glaring sensation levels and brief moments of exposure has ever since dominated the American experimental research on discomfort glare.*

*Hopkinson introduced the "ABCD criteria of discomfort glare." These criteria are still used in Great Britain, and the rationale for employing them has gradually been worked out (Hopkinson, 1950). During continuous exposure to glare, the subjects adjusted the background luminance of the glare source (set by the experimenter) so that the total impression was that of one of the specified degrees of discomfort (A=Just intolerable, B=Just uncomfortable, C=Satisfactory, D=Just not perceptible). Hopkinson noted that the subjects found it much more difficult to make the observations when they were asked to control the source brightness than when controlling the background brightness. The use of letters to label the discomfort glare categories was deliberate, and Hopkinson even stated that the ABCD scale should not be treated as a numerical rating scale.*

*Hopkinson designed an experiment aimed at comparing direct magnitude estimations of brightness and discomfort glare. The subjects, so far as possible naive in the context, were asked to adjust conditions in a room with glaring light sources until the experienced discomfort was "twice," "ten times," "one-half," and "one-tenth" of the original (standard) level of discomfort.*

*Luckiesh and Guth worked out a standard technique for momentary exposure to glare to approximate the conditions where a worker looks up from his normal adaptation brightness, such as the brightness of a table top, to a source of higher brightness. The exposures consisted of repeated cycles of 10 seconds length: 1 sec exp-1 sec interv-1 sec exp-1 sec interv-1 sec exp -5 sec interv. The subject's task was to adjust one parameter of the glare source so as to give a sensation "at the borderline between comfort and discomfort." This was called the BCD sensation.*

*Kronlund et al. (1970) investigated the role of lighting at building sites. It was not a pure study of discomfort glare as their interest was the "goodness" (from the workers' point of view) of the flood lighting, but the study is worth mentioning because of the method employed. The worker was asked to call out the "goodness" of the light provided to his workplace, and the "goodness" should be given in relation to the very best lighting he could think of when performing that particular job. The very best should be denoted "100."<sup>9</sup>*

The problems associated with glare and specular reflection are traceable to one characteristic of lighting design—the presence of a bright source of illumination. Another property of many building lighting systems which has been a cause of complaints (especially in the case of fluorescent lighting) is their intermittency, that is, fluctuations in light output, perceived as flicker.

<sup>9</sup> O. Ostberg and P. Stone, "Methods for Evaluating Discomfort Glare Aspects of Lighting," *Goteborg Psychological Reports*, 4 (1974).

## Flicker Perception

In the early days of fluorescent lighting, flicker was a problem for two reasons—types of phosphor used and ballast design. Both of these problems have now been largely overcome in modern lighting systems.

The topic of the perception of flicker has been one of theoretical interest for researchers and of practical concern to lighting designers because of the operating characteristics of fluorescent lamps. J. Collins (British physicist) conducted a number of investigations to explore this subject. He employed a box containing a uniformly illuminated white screen which occupied a large field of view. Toward the top of the field of view, a small slit was illuminated from behind by a fluorescent lamp. The visual field was caused to fluctuate with respect to luminance by means of a sectored disc mounted in front of the eyes of the subject. The subject controlled the speed of a motor driving the disc. His instructions were to judge when the following conditions were experienced: "just obvious flicker," "just uncomfortable flicker," and "just intolerable flicker." The experimenter measured the actual rotating speed of the disc while these judgments were made, by means of a **stroboscope**.

R. Hopkinson (architect) indicates that:

*The visual effect of a light which is fluctuating may be perceived in one or both of two ways. The light itself may not be perceived directly as flickering, but it may be noticed that objects which are moving appear to move in jerks . . . . On the other hand, if the frequency of the fluctuation is low, the actual fluctuations may be perceived by the eye either in the light source itself or in the illuminated visual field.<sup>10</sup>*

Recently, illuminating engineers have become more conscious that an important aspect of the quality of illumination relates to the spectral (wavelength) composition of the light, and its effect on the appearance of colored objects. Discussion of illumination color is taken up in the next chapter.

## Lighting Measurement Methods

The subject of lighting will be dealt with from the standpoint of its effects on the people who occupy buildings. Most of the investigations described are designed to determine how well people can see under various conditions of illumination. Our major interest is to indicate *how* data were collected, not the findings and recommendations resulting from these studies.

<sup>10</sup> R. G. Hopkinson and J. B. Collins, *The Ergonomics of Lighting* (London, 1970).

## Visual Acuity Approaches

Most studies of visual acuity—which are designed to determine the limits of the eye to resolve fine detail—are based on psychophysical procedures analogous (or identical) to those used to detect the presence of light. The studies are designed to determine appropriate levels for illumination in buildings to perform specific activities. Recently, the general applicability of such an approach for *all* lighting has been questioned.

One method employed by illumination researchers was based on the commonly used Snellen eye charts familiar to most people who have had their vision tested. M. Gilbert and Hopkinson studied the effects of

various illumination conditions on a series of such charts. In addition to the usual black letters on a white background, they used white letters on a black background, and white letters on backgrounds of various shades of gray. (The study was designed to simulate a classroom chalkboard task.)

The Snellen eye chart is used to determine the capability of a person to distinguish details in a pattern of visual stimulation. Another technique often employed for the same purpose is the Landolt ring. This is a circle with a gap in it (a letter “C” with a narrow opening). The gap can appear at any part of the circle, and the task of the experimental subject is to determine where the gap is.

## Several Acuity Measures

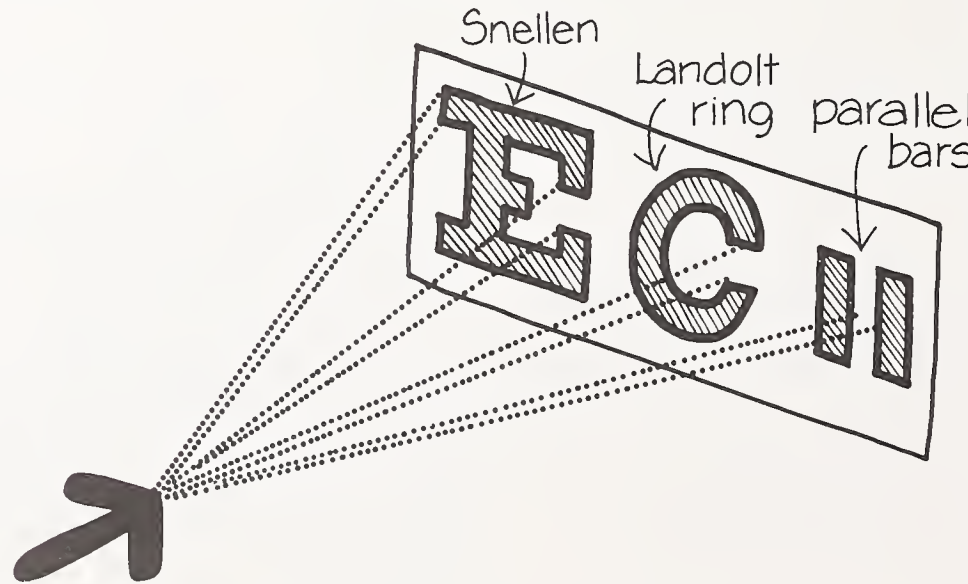

## Illumination Levels Recommended by IES\* Selected Tasks and Spaces

Situation or task	Recommended Illumination, footcandles
<b>Assembly:</b>	
Rough easy seeing	30
Rough difficult seeing	50
Medium	100
Fine	500
Extra fine	1000
<b>Machine shops:</b>	
Rough bench and machine work	50
Fine bench and machine work	500
Extra-fine bench and machine work, grinding—fine work	1000
<b>Storage rooms or warehouses:</b>	
Inactive	5
<b>Offices:</b>	
Cartography, designing, detailed drafting	200
Accounting, bookkeeping, etc.	150
Mail sorting	100
Corridor, elevators, stairways	20
<b>Residences:</b>	
Kitchen, food preparation	150
Reading, writing	70

\* IES Handbook, 5th ed., 1972



R. Lythgoe (British physicist) performed a study with a Landolt ring to determine the effect of the surround on the ability to perform a simple visual acuity task: the determination of the minimum size of detail which can be resolved. The luminance of the surround was varied from well below that of the task to a value considerably above the task.

The *Illuminating Engineering Society Handbook* is the single most influential source document for the lighting levels now recommended for buildings in the United States. These levels have been developed in large measure as a result of the work of H. Blackwell and his associates (psychologists). Blackwell has employed a variety of techniques in his investigations. His early work made use of a procedure where a circular target was presented to subjects at the center of a field of uniform luminance.

### Luminous Disc (Blackwell)

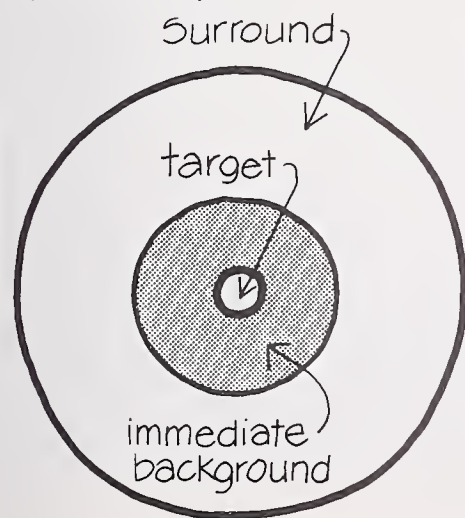

The target consisted of a uniform luminous increment presented within a circular area on a uniform background field. The target was presented at a number of contrast levels above and below the level of the immediate background, for periods ranging from 0.001 to 1 second. Experimental subjects were told the size and positioning of the target as well as the duration of exposure. Each experimental trial consisted of four time intervals. The task of the subject was to identify the particular interval during which the target actually appeared. The subject was forced to choose one of the time intervals, whether or not he thought he detected the target. This "forced choice" procedure is more sensitive than the more common one which requires the subject to report only whether or not a flash was seen.

### Detection Task

Percentage accuracy as a function of target contrast.

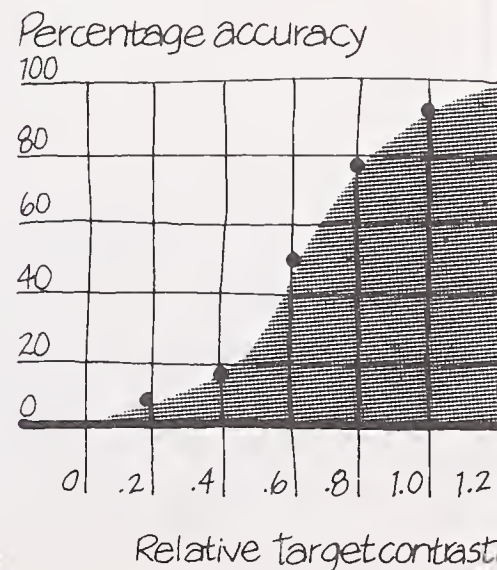

While Landolt rings, discs and Snellen Eye Charts have been used to simulate difficult visual tasks such as might be encountered in buildings, these methods have limited application. In the experiments discussed so far, subjects knew where to look for the stimulus; it was not necessary for them to locate the material to be viewed. However, there are many tasks performed in buildings which have this added dimension—the need first to find something and then to perform some follow-up activity. For example, proofreading of printed material requires one to determine whether errors exist, and if so, correct them. This involves a type of scanning procedure, without knowing where (or if) errors exist. Industrial inspection tasks such as wiring provide another instance of the need for this type of activity. The methodologies used for static tasks were sometimes modified to meet these dynamic task situations. Other techniques have been developed to better understand "visual search" activities such as locating targets on radar displays.

The Landolt ring was used as a "building block" in a chart of rings in studies by M. Weston (British physicist). He printed a series of such charts with different levels of contrast. The task of the subject was to cancel every ring with a gap in a specified direction by means of a pencil marking. In order to accomplish this task, the entire array of rings had to be searched systematically. Performance of the task was measured in terms of speed as well as accuracy.

O. Blackwell (psychologist and wife of H. Blackwell) has used two procedures in her studies of illumination needs in various population groups. She employed a display of five Landolt rings, one in the center of four others in one study. The location of the "open" rings was changed. A random succession of displays with from zero to five open rings was presented for 1 second each, after which time the subject reported the number of rings opened at the right. The performance of subjects was better when contrast ratios were higher.

### Weston Landolt Ring Performance Chart

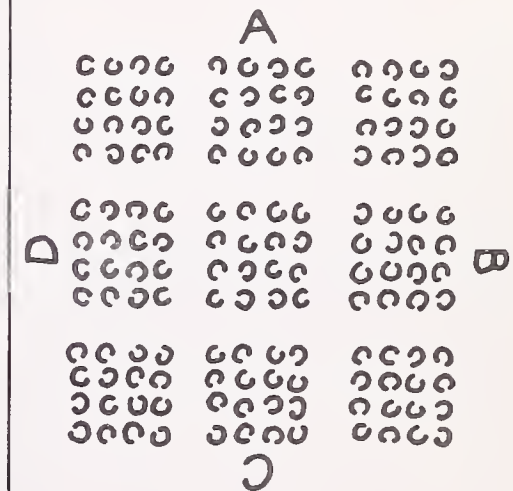

Another procedure used by O. Blackwell was to have a subject look through an aperture at a luminous screen with a small spot (4 minutes) of light at the center. The task of the subject was to adjust the spot of light until it was "barely visible" against the background. The illuminance of the screen was systematically varied, upward and downward, for a series of trials, to determine visual performance. In both studies, older people required more light than younger ones for comparable performance.

H. Bodmann (German illuminating engineer) developed a more elaborate (and automated) method to examine the type of "search" task developed by Weston. Bodmann employed a chart, with the numbers from 1 to 100 randomly distributed on the surface.

The experimenter called out a number, and the subject had to locate the number and to touch a hole adjacent to the number with a metal pointer. The pointer was connected electronically to recording equipment, which provided an indication of the time taken to respond. The variables examined in the study were the size of typeface used for the numbers and the contrast of the type with the background.

The Field Task Simulator was developed by H. Blackwell to more closely approximate "real world" viewing conditions. The apparatus consisted of a large rotating wheel, which contained 50 luminous disc targets on the periphery. Targets were produced by adding luminous increments to some discs by means of projectors mounted below. The circular wheel was rotated at a number of different speeds. The subjects were to indicate that they detected a target by pressing a button mounted on the simulator.

The tasks described thus far are laboratory methods developed to better understand how people see. In recent years, researchers have used more realistic tasks to better understand lighting requirements for particular industrial and commercial building environments.

A series of realistic industrial and commercial studies under varied conditions of illumination was conducted by S. Smith (psychologist). One of these studies involved the use of three-dimensional objects—

Lincoln pennies. The task of the subject was to read the dates of pennies of three qualities (new, worn, badly worn) as quickly and as accurately as possible. The subjects performed this task using an eye marker camera requiring a fixed head position.



*Realistic Task Study (S. Smith)*

### Bodmann Search-Task Chart

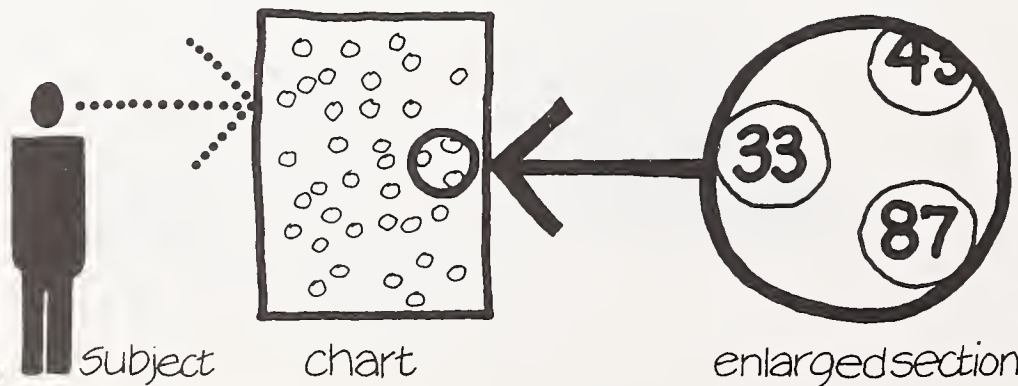

A camera was used by L. Buttolph (consulting illuminating engineer) to determine how people perform visual work tasks in realistic settings. He set up time-lapse cameras in offices and schools to determine the typical viewing angles employed by people. In his school survey, he examined fourth, seventh, and ninth grade students. In the office work, which lasted for several months, he took thousands of frames of stop-action motion picture film.



## Suprathreshold Studies

Yonemura has developed a research approach designed to be more realistic in terms of the visual task than the one traditionally employed in lighting studies. The primary differences between his method and that of H. Blackwell, for example, are concerned with the instructions to the subject and the task employed in the study. In contrast to the absolute threshold judgments usually employed in lighting studies (something that can barely be seen), Yonemura has used suprathreshold tasks (objects which can readily be seen). However, subjects have a different judgment to make—instead of *can (or cannot) detect the object*, they determine “how well” the object can be seen.

In his first investigations, one using sine-wave gratings and another employing square-wave gratings (see illustration), observers were asked to vary the contrast of a grating pattern so that it appeared to be equal in contrast to an adjacent grating pattern identical in all respects except for mean luminance. Starting with a high level of luminance, levels were systematically lowered until apparatus limitations were reached. (The results obtained using this technique differed considerably from those achieved with traditional approaches; namely—increased lighting levels did not produce better task performance. Instead, an optimal lighting level was found; beyond which, task performance declined.)



Square Wave Grating; Yonemura Study (NBS)

## Summary Visibility Data (Yonemura)

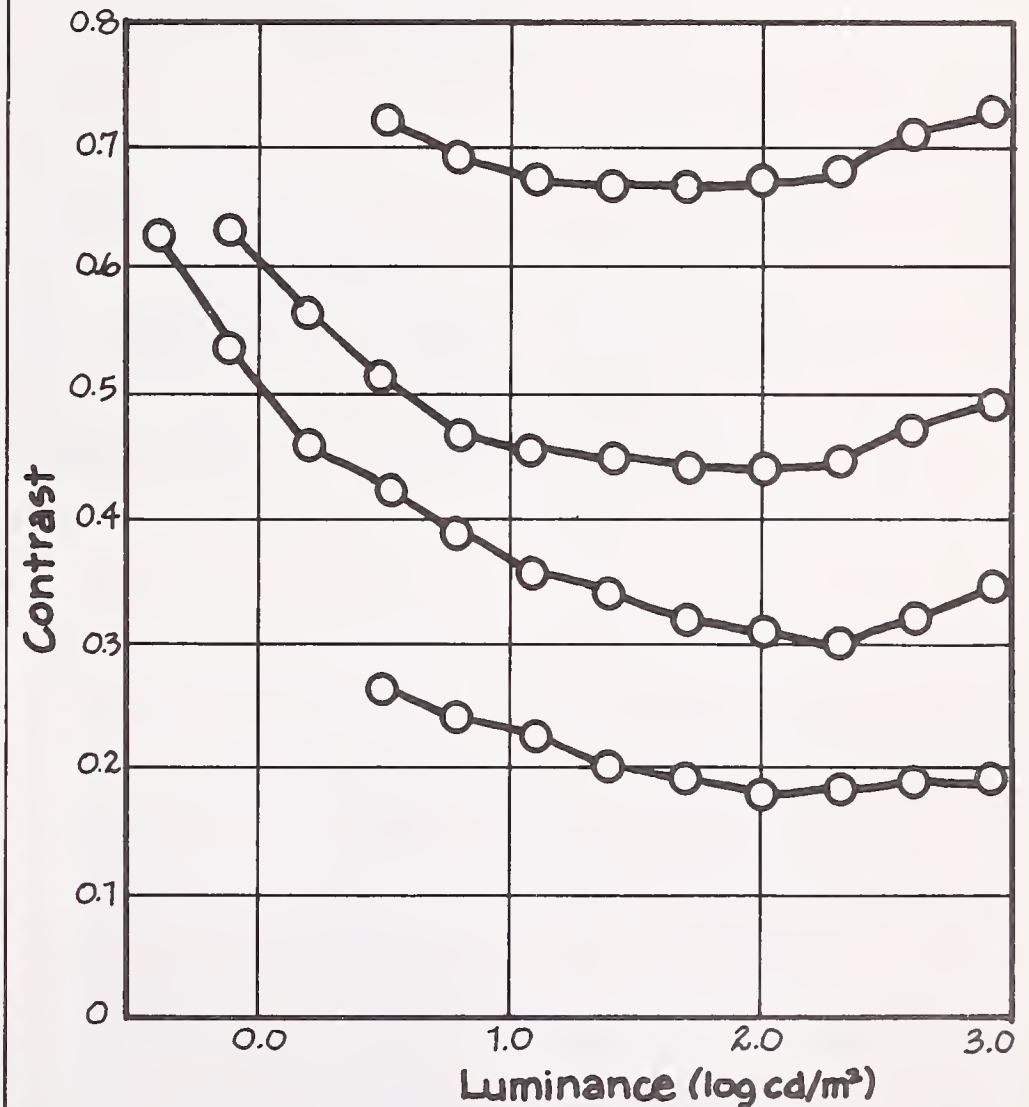

Yonemura then did a follow-up study. He was interested in determining whether he would obtain similar results as to illumination requirements if the experiment were conducted using more realistic tasks—judgments of printed matter. Since reading is a widespread activity in buildings, this appeared to be a logical first step in following up the initial studies. Charts were printed at different levels of darkness on a variety of backgrounds ranging from white to dark gray. That is, contrast ratios were explored. Another variable examined was the level of lighting associated with the task. As in the previous instance, the response of the subject was to judge which of two compared stimuli was clearer. The findings in this study were consistent with those obtained in the earlier investigations.



Printed Matter; Yonemura Study (NBS)

man oxen 25 37 84 90 OXNO OXXX

raw see van 90 89 76 60 54 XOXOX OXOOO

noon even mew 34 73 80 93 84 80 76 XXOX XXXX OOX

man oxen 25 37 84 90 OXNO OXXX

raw see van 90 89 76 60 54 XOXOX OXOOO

noon even mew 34 73 80 93 84 80 76 XXOX XXXX OOX

raw see van 90 89 76 60 54 XOXOX OXOOO

noon even mew 34 73 80 93 84 80 76 XXOX XXXX OOX

raw see van 90 89 76 60 54 XOXOX OXOOO

noon even mew 34 73 80 93 84 80 76 XXOX XXXX OOX

raw see van 90 89 76 60 54 XOXOX OXOOO

noon even mew 34 73 80 93 84 80 76 XXOX XXXX OOX

raw see van 90 89 76 60 54 XOXOX OXOOO

noon even mew 34 73 80 93 84 80 76 XXOX XXXX OOX

Research Procedure; Yonemura Printed Matter Study (NBS)

A review of the lighting factors which are of interest to architects reveals that not only light but shadow effects, too, are significant (mood, emphasis, expression of intended use, modification of appearance). C. Neenan (lighting designer) indicates that lighting cannot be understood without a knowledge of shadow effects. In describing shadow effects, Neenan indicates that:

*The physical size of the light source determines the density of the shadow, and the optical characteristics determine the acuity, or sharpness, of the edges of the shadow. The shadow cast*

*by a soft light has a feathered edge. The gradual change in shadow density from the shaded area to a lighted area is an asset when it is necessary to blend the light of luminaire groups. It can be a liability when shadow acuity is desired.<sup>11</sup>*

A test has been designed to describe and quantify the shadows produced by luminaires called the "shadow factor test." The test involves measuring the **incident light** falling on a test area both before and after a shadow is cast on it. This approach is said to provide an effective means of evaluating shadows.

## Shadow Apparatus (Neenan)

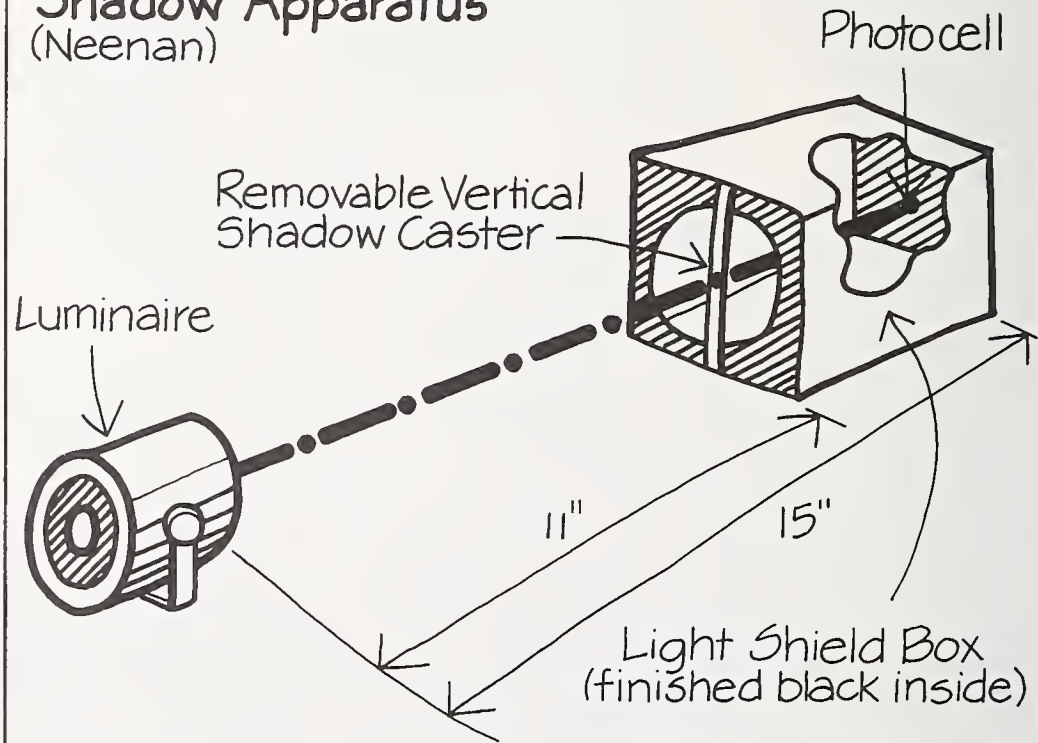

<sup>11</sup> C. J. Neenan, "Shadow Characteristics of Stage Lights for Theatre, Television and Motion Pictures," *Illuminating Engineering*, 63 (1968).



## Subjective Appraisals

Recently it has been possible to study some of these factors by the method known as the **multiple criterion technique**. After identifying a set of variables which are sensitive to lighting conditions, subjects adjust one physical parameter at a time based on some preselected criterion. (The subject may increase the apparent size of reading type to maximize the ease of reading, while the illumination level on the type is maintained at a constant level. By performing this type of test at each of several levels of illumination, a set of equal sensation curves is obtained which relate the type size with varying levels of illumination.)

The above procedure has been modified in some investigations. Instead of having the subject control the characteristics of the stimulus, the experiment is carried out under a fixed, predetermined set of conditions. The subject's performance is then examined over a period of time to determine whether his responses are consistent from trial to trial during the course of the study. The critical data in this approach consist of the variability of responses over time. This approach has the advantage of providing standardized conditions to all subjects which facilitates data collection and analysis. When subjects are permitted to vary conditions, many do it rapidly, others slowly, because a considerable degree of judgment is involved.

An example of an experimental method for appraising a lighting installation is that by Stiles and his colleagues in the assessing of street lighting. They employed street lighting experts to obtain their opinions on a number of installations in various streets. The observers were asked to assess the visibility, the attractiveness, and the degree of glare of various installations on arbitrary scales. Attempts were then made to correlate these collective opinions of the installations with various physical facts which had been measured.

Hewitt describes an *appraisal* method carried out by a small team of experienced observers (architects and lighting designers). They used the following approach. A questionnaire is issued to observers before they enter the room. They are asked first to record their initial impressions of the interior. Next, they answer questions on such items as the furnishing and decorations, the way in which stated visual tasks are lighted, discomfort glare from windows or artificial lighting, sparkle, specular

reflections, directional qualities, color rendering, and brightness distribution. Having thus made an appraisal of the lighting effects, observers are asked to judge the methods of lighting, i.e., the windows, the light fittings, and the arrangement of the lighting installation. Finally they are asked to make an overall judgment to identify critical factors associated with lighting and rank those factors which seem to have had the greatest influence on their opinion. Each appraisal takes from 30 to 40 minutes excluding the time required for taking measurements of illumination and luminance.

Hopkinson indicates that the appraisal of lighting must be undertaken by the user of the lighting. Objective measurements can only show how the lighting measures up against physical standards which must themselves have been determined by a subjective appraisal if they are to convey any notion of the excellence of the lighting.

## Conclusion

While illumination research goes back many years, many problems are evident when we consider user requirements. Most research concerned with defining lighting level needs was developed under threshold laboratory conditions, with young adults serving as subjects. Recent work has shown that these early studies must be supplemented by field studies of realistic tasks, suprathreshold investigations, and examinations of the needs of special populations such as the elderly. On the other hand, we must not neglect the quality of illumination. The positive features of lighting (psychological and/or aesthetic) are not well-understood either, and merit attention. Finally, studies of the relationship between natural and artificial illumination are required—especially in view of the need to conserve energy.

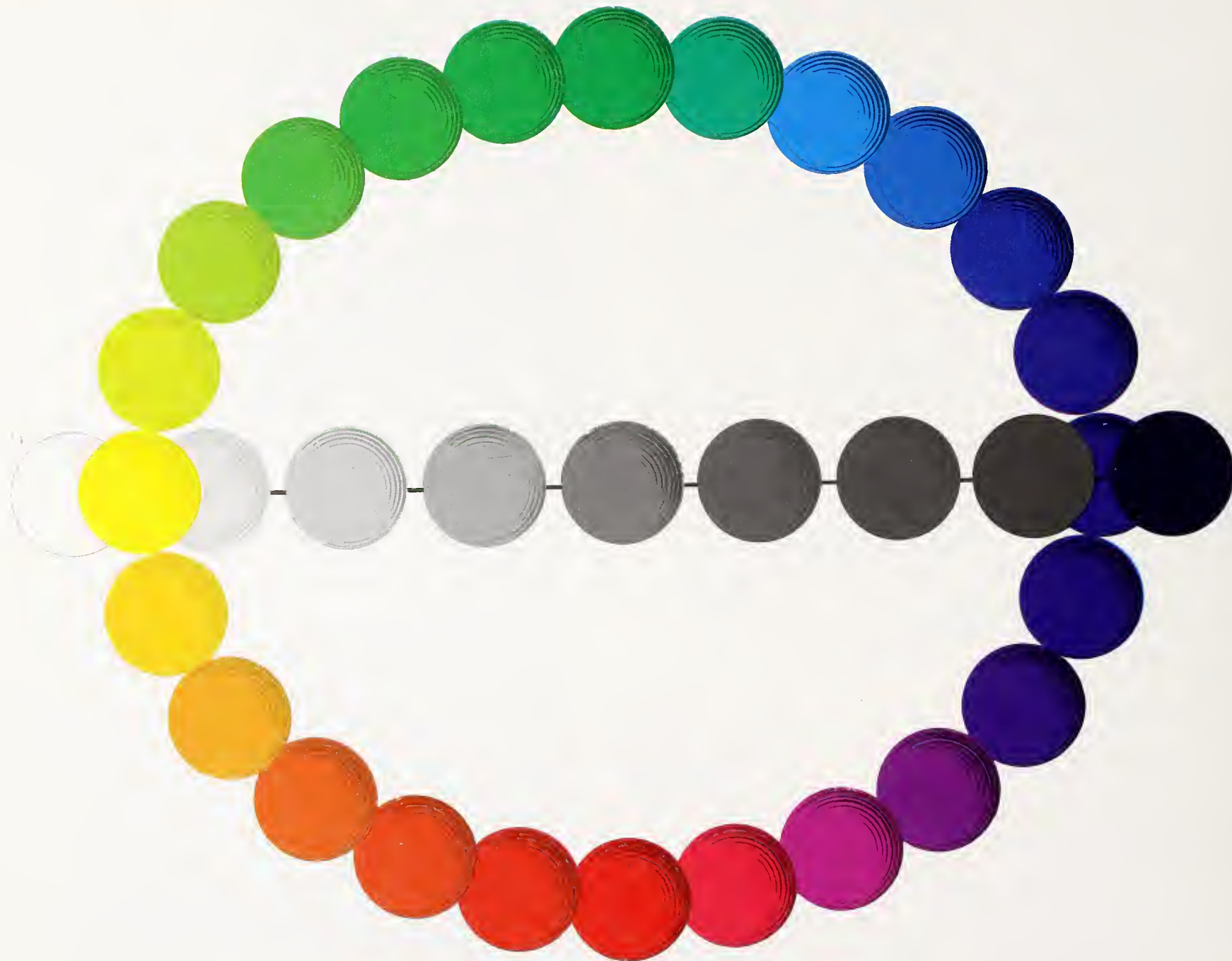



# 13

## Color

---

Color Rendering—The Effects of Light on Objects  
Factors Influencing Color Perception  
Color Classification Systems  
    Munsell System  
    Natural Color System  
Studies of Color in Buildings  
Conclusion

---

### Families of Color: Light/Dark— Vivid/Grayish <sup>1</sup>

*In addition to families of hues, we have families of light colors and families of dark colors. The samples illustrate the way in which these colors relate to each other.*

*To describe any color you have to be aware not only of its hue, but also of its lightness and darkness, and its vividness or grayishness.*

---

<sup>1</sup> D.B. Judd, *Color in Our Everyday Lives* (Washington, D.C., 1975).

We have covered two aspects of the visual environment in the present part of this work—illumination and perception. Color is a component part of each of these problem areas, and we will now discuss it at some length. The complexity of color, its importance in design, and the breadth of its literature necessitate this approach. Unfortunately, however, few studies dealing with color in buildings have been performed. Instead, the research literature deals more with how people classify, measure, and perceive colors.

Color is a fundamental characteristic of both materials and light. It is therefore not surprising that color has received attention from the scientific, artistic, commercial, and design communities. For the architect in particular, color provides an important additional attribute which can be incorporated into many aspects of his work—whether pragmatic or aesthetic. The architect therefore would like a better understanding of the effects of colors on people.

Color research presents a microcosm of many problems which face social scientists and architects working in collaboration. The architect wants colors which can be employed to evoke moods and feelings, call attention to selected attributes of buildings, and generally enhance the environment. The goals are therefore primarily subjective ones—rooted in emotional and aesthetic experiences.

Color research, in contrast, has until quite recently remained in the mainstream of the classical (objective) scientific research tradition—dating from the time of Newton (chap. 19). The study of color, however, is by no means limited to physics. D. Judd (physicist and colorimetrist) indicated that the study of color has several aspects—chemical, physical, psychological, and physiological. He noted that *the study of color is neither purely physical or psychological but can best be described as the evaluation of radiant energy in terms of the visual perception of the human eye. The measurement methods of color are therefore ultimately based on the ability of a person to make evaluative judgments concerning the stimuli presented by an experimenter.*<sup>2</sup>

One of the factors which stands in the way of an understanding of color is the extraordinary sensitivity of the average person with respect to distinguishing colors from one another. Under ideal viewing conditions, the number of distinguishable colors is estimated to be between 5 and 10 million. As a means of dealing with this large number of colors, considerable efforts have been expended to develop procedures to categorize colors as simply as possible, i.e., to identify basic parameters and classify colors accordingly. Of particular interest is the fact that the major impetus for this work was provided by artists intent on teaching the use of color to students—A. Munsell and T. Johansson.

<sup>2</sup> D. B. Judd and G. Wyszecki, *Color in Business, Science and Industry* (New York, 1975).

---

*Color serves many esthetic purposes in the design of buildings.*

*It creates an atmosphere. A bright color scheme for a building tends to express gaiety and excitement; a quiet scheme may express dignity and repose.*

*It suggests either unity or diversity. A uniform color scheme contributes a sense of unity, while a varied color scheme gives a feeling of diversity.*

*It expresses the character of materials. If a building has a red tile roof, gray stone walls, and brown wood trim, the essential character of each material is clearly stated. If these have the same color, the building looks like a clay model.*

*It defines form. A line, a two-dimensional surface, or a three-dimensional volume is defined if its color contrasts with its surroundings.*

*It affects proportions. Materials with contrasting colors laid in horizontal lines tend to emphasize a feeling of breadth. If laid in vertical lines, they promote the sense of height.*

*It brings out scale. A building made up of elements of uniform color looks like a monolith. Its scale is difficult to judge at a distance. If, however, its elements (including openings) are of contrasting colors, the scale of the building is more easily conveyed.*

*It gives a sense of weight. Elements in dark colors look heavy; those in light colors look light in weight. For this reason, the color of tall structures is sometimes graduated from dark at the bottom to light at the top.<sup>3</sup>*

---

Another obstacle to the study of color is the widespread finding that people respond to colors in highly individual ways. That is, considerable individual differences are apparent with respect to major color responses—e.g., color preferences. One goal has been to respond to the needs of the marketplace. This effort has been directed toward adequately specifying colors to permit agreement between potential buyers and sellers of products where color characteristics are important—e.g., paints, raw materials, finished products.

<sup>3</sup> W. Faulkner, *Architecture and Color* (New York, 1972)

The attributes described above by Faulkner are only concerned with *object* colors—i.e., colors associated with the surface characteristics of materials and objects. Our experiencing of color is considerably more complex, however. The perception of a particular color in the environment is dependent not only on the energy distribution of the source, or on the properties of an object which result in the selective transmission, reflection, and absorption of particular wavelengths, but on the interaction of the properties of light and objects. We will discuss this topic first, because of its importance.

---

## Color Rendering—The Effects of Light on Objects

---

*The light striking an object will be affected by interaction with the object in a number of different ways. The resulting light distributions give us our impressions of what the object looks like. Specular reflection, for example, makes the object look glossy or shiny. Metals are distinguished by stronger specular reflection than that from other materials, and smooth surfaces are always shinier than rough ones.*

*The diffuse reflection caused by the scattering of light within a material, where no selective absorption by dyes or pigments is involved, causes a white appearance. White paper, for example, is white by diffuse reflection. This means it must contain many internal surfaces, each of which reflects some of the light. This is indeed the case, as paper is composed of many small fibers. It is white because the fibers absorb almost no light. Snow, talcum powder, milk, and all other white materials look white because they scatter light by multiple reflection but do not absorb it.*

*When absorption is the dominant process, dark colors result. If all wavelengths are absorbed, black results. Selective absorption of just certain wavelengths results in our perception of color. In the majority of objects all these processes are operating; specular (shiny) reflection, diffuse reflection by scattering and absorption.<sup>4</sup>*

---

The topics of color and lighting are inseparable when the concern of the architect is color rendering—the effect of lighting attributes on color appearance.

The light reaching a viewer's eye from the objects in a room determines what colors the objects appear to be. For each object, the light sent to the eye depends on the amount of light reflected from each wavelength of the light source that shines on the object. If the light source, for example, contains no red wavelengths, it does not matter how reflective the object is in the red part of the spectrum; there is no red light for the object to reflect.

An extreme example of such a light source is the low pressure sodium discharge lamp, which has virtually all its energy in a narrow band of the yellow part of the spectrum. Under such a source, all objects appear yellow, with the only differences being in the amount of yellow reflected. The advent of the energy crisis has intensified the need to be sensitive to problems of color rendering, since often there is a tradeoff between energy efficiency and the color rendering properties of lamps. This problem was recently studied by two researchers.

<sup>4</sup> Judd and Wyszecki



S. Aston and H. Bellchambers conducted a study to determine the tradeoffs between two qualities of lights—efficiency and color rendering. Two cabinets were designed and furnished as identical miniature rooms with the colors of the objects and surrounds of the room carefully specified. One cabinet was illuminated by fluorescent lamps with good color rendering properties and the other by fluorescent lamps with high luminous efficiency. The observers in the study stood in front of the two cabinets so as to have a full view of both.

Illumination levels in the high luminous efficiency cabinet were set at three different levels (standard). Subjects were asked to adjust the levels of the other fluorescent lamps (comparison) until they were equivalent to the standard in terms of “overall clarity.” The average light intensity levels set were considerably below those of the three levels established as standards. In other words, subjects accepted less light when the light rendered colors well.

Even more serious than the aesthetic problems that might arise from color distortions produced by light sources are the possible safety implications. Thus, under some lighting systems, red danger signs may appear to be orange or brown. The safety warning signal embodied in the red color is thereby lost or transmitted into a wrong message.

## Factors Influencing Color Perception

The inability to perceive color coded messages is not confined to characteristics of lights. Many people have color deficiencies which prevent them from responding reliably to chromatic signals, safety markings, or color coding. Many types and levels of color deficiency have been identified.

Since the time of Gestalt psychology, researchers have been aware of the importance of context on the way that object colors are perceived. For example, D. Katz (psychologist) examined colors by means of a “reduction screen,” with a hole in it. When an object is seen through such a screen a colored surface appears as a **film color**, because the screen eliminates the perception of context—position, illumination, relation to surroundings. This work on film color was done in conjunction with research which showed that the surface colors of objects remained constant despite the characteristics of illumination. This result is explained by the cues available in the situation, e.g., an object recognizable as a lemon appears yellow even when illuminated by a colored light (within limits).

Katz identified three kinds of colors: *Surface colors* which are two dimensional, localized at a given distance and usually the colors of perceived objects; *volumic colors*, which are the tridimensional colors of transparent media, like colored liquids, colored air; and *film colors*, which are primary and without localization or precise spatial characteristics.

Judd notes that determining the pleasantness of color combinations is not only complicated but controversial. A widely held view is that color preference combinations depend too much on individual taste, and are therefore too complicated for scientific study. Despite the difficulties posed by the topic, H. Helson (psychologist) conducted a study concerned with the judgment of the pleasantness of color combinations under varied lighting conditions. The investigation was performed in a light booth employing 10 observers—5 males and 5 females. The subjects viewed 125 chips (5 cm square) on each of 25 background colors under five different sources of illumination—incandescent and fluorescent. Each of 3,125 object background color combinations was viewed 5 times—once under each lighting condition. Colors of 20 uniformly distributed hues were shown. For each hue there were ranges of grayish colors and various degrees of saturation. The color chips were viewed 12 at a time with the subjects being asked to rate each combination for “pleasantness,” on a scale from 1 to 9 (1 = very, very unpleasant, 5 = neutral or indifferent, 9 = very, very pleasant).

The major findings (not to be taken as definitive) were as follows:

- The most notable finding was that to be pleasant, an object color must stand out from the background color by being definitely either lighter or darker.
- Women rated all lights higher than men for object colors of “warm” hues (red to yellow); men rated them higher for “cool” object colors (blue to red-purple).
- Light or dark background colors were preferred to intermediate ones.
- Preferred object colors (in order) were green, blue, and purple.

Judd discussed the influence of other colors on color perception:

*THE SAME COLOR MAY APPEAR TO VARY IN LIGHTNESS AND GRAYNESS. Every color is influenced by the color next to it. Whenever colors are brought together which differ in any respect, their differences appear greater. The panels in the accompanying illustration show this effect. The smaller rectangles in each pair are the same color. (Check by masking.) In the upper pair on this page the inner gray panel appears darker on the light background and lighter on the dark background. In the middle pair the inner green appears less gray on the gray background and more gray on the green background. In the lower pair the inner green appears both lighter and yellower on the dark blue background and darker and bluer on the yellow background.<sup>5</sup>*

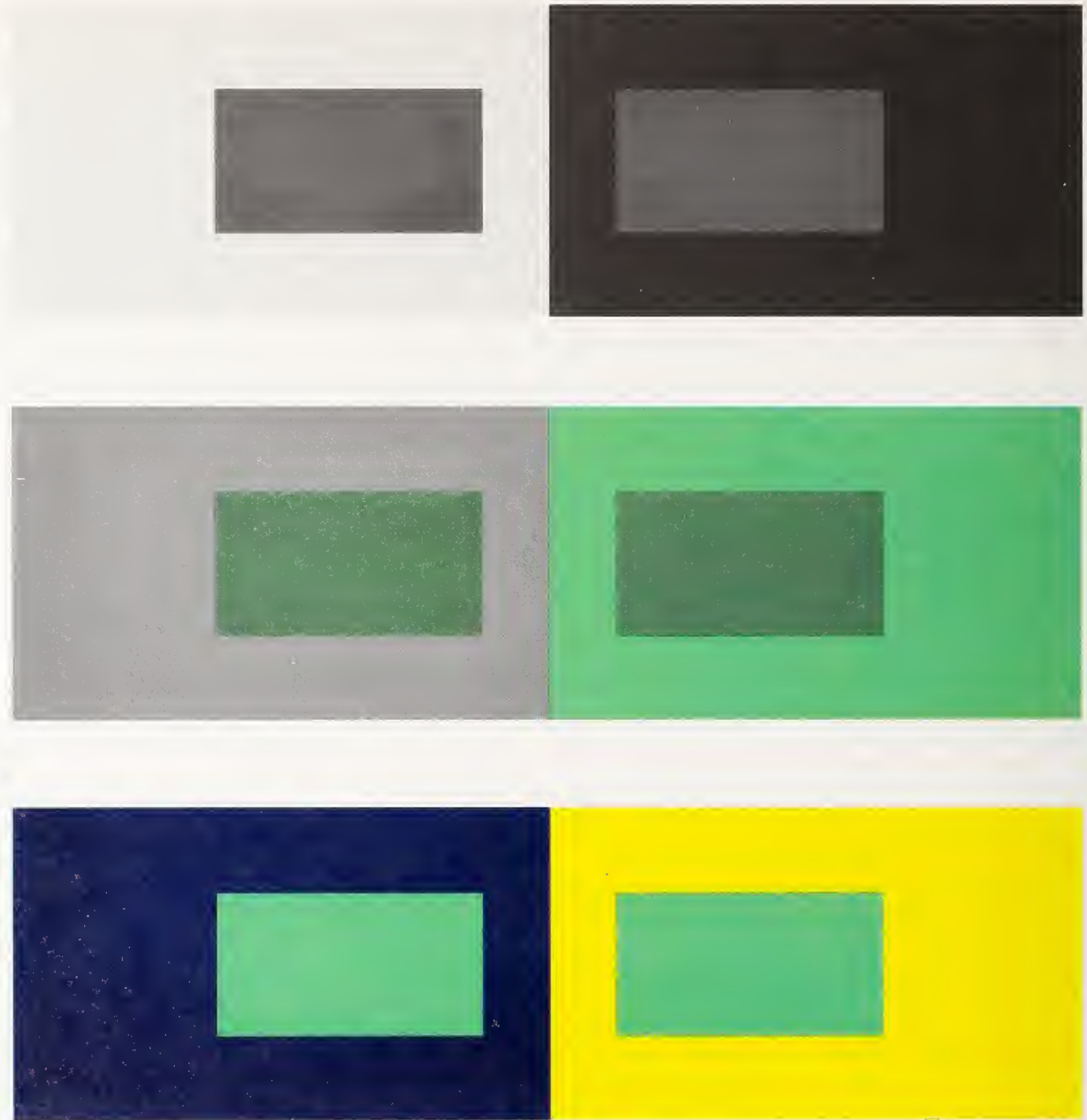

<sup>5</sup>Judd



IDENTICAL COLORS MAY APPEAR TO VARY IN LIGHTNESS AND HUE. In the upper pair ... the inner orange panel appears darker and redder on the yellow background and lighter and yellower on the red background. In the middle pair the inner beige appears darker and redder on the green background and lighter and yellower on the blue background. In the lower pair the inner yellow panel appears slightly redder on the blue background and slightly greener on the magenta background. These induced color effects are ever present and are of greater or lesser extent depending upon the particular situation. These induction principles are helpful when a fixed or existing color must be presented in the most favorable way through choice of a new surrounding color or group of colors.<sup>6</sup>

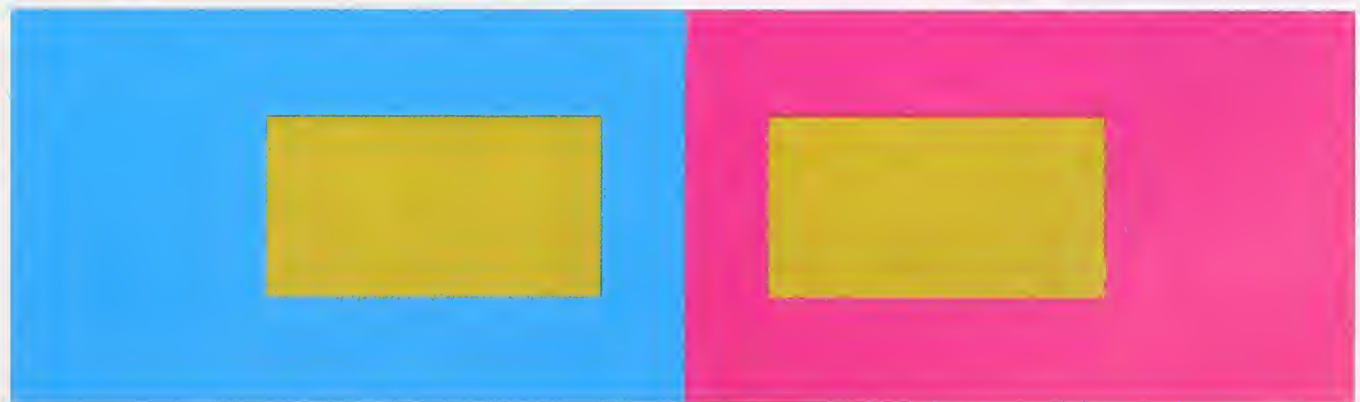
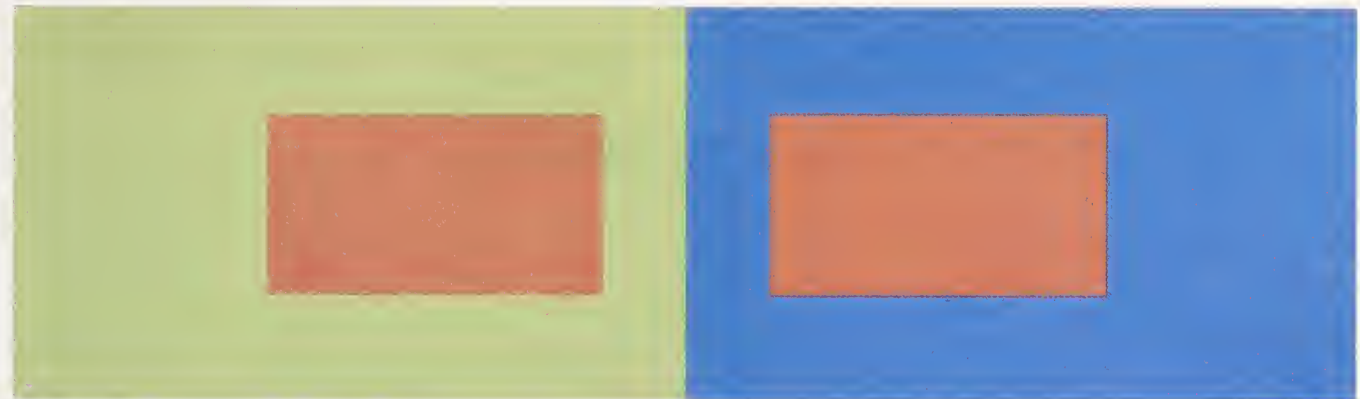
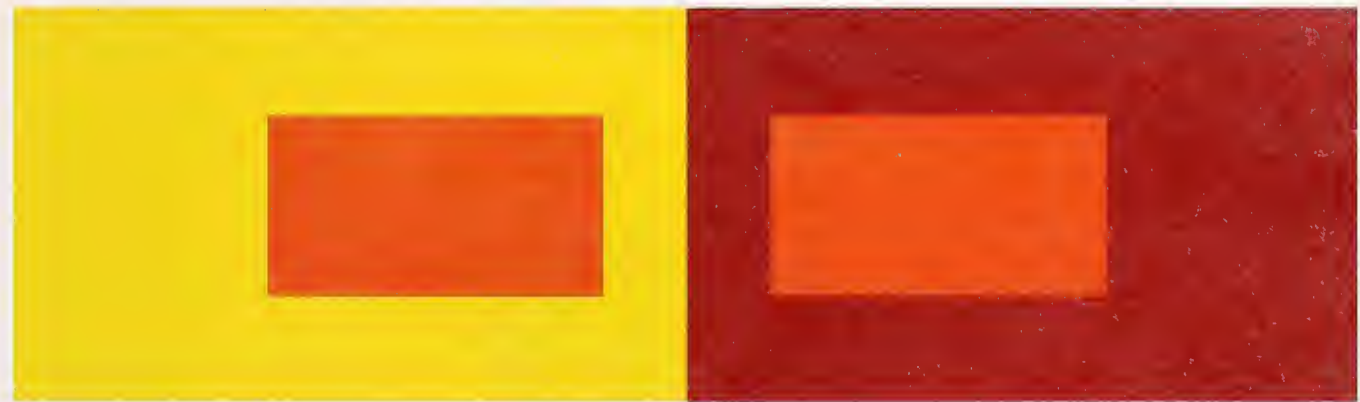

<sup>6</sup>Judd

HARMONY USING NEIGHBORING HUES. Another kind of harmony results from using neighboring hues with appropriate lightness differences.<sup>7</sup>



<sup>7</sup> Judd

The topic of color harmony brings us to the research performed to develop an orderly way of describing the countless colors which can be differentiated by people. The architect, the consumer, the manufacturer, and supplier of raw material, all require the means to specify colors to ensure satisfaction with goods being purchased when color is an important attribute. Fortunately, considerable research has been performed to specify and classify colors in an orderly way.

### Color Classification Systems

Suppose that an observer on a deserted island finds a large number of colored pebbles and wishes to arrange them as to color in some orderly manner. Let us assume that he chooses first to separate the colored (chromatic) pebbles (red, yellow, blue, green, etc.) from the colorless (achromatic) pebbles (white, black, or gray).

The observer might then arrange the achromatic pebbles in order from white, through light gray, to dark gray, and finally to black according to their lightness or value. He might also arrange the chromatic pebbles, first according to their hues (the reds together, the yellows together, etc.). He might then realize that these would also vary as to lightness, or value, and might arrange them systematically (the light reds together, the medium reds together, etc.) in the same way that he arranged the achromatic pebbles. However, he might notice that the colored pebbles differ from each other in another way, besides hue and

### "Desert Island Study" (After Billmeyer and Saltzman)

First, separate "achromatic" from "chromatic" pebbles...



achromatic                  chromatic

...and arrange them in order of lightness:



Next, separate chromatic pebbles by "hue"...



...and then by lightness within each hue:



Finally, subdivide each group on the basis of gray vs. color content, "chroma" or "saturation".

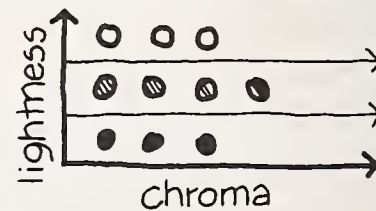



lightness. Some of the red pebbles might be bright red, like tomatoes, and others a dull red like brick. This quality determines the strength of the color, as compared to gray, and is known as saturation or chroma.

If our observer is both unusually sensitive to color and highly intelligent, he would then have arranged the pebbles according to their hue, lightness, and saturation, as three of the basic attributes of color, all of which must be noted to describe or specify a color completely.<sup>8</sup>

Several color classification systems have been developed. They differ in terms of how colors are described and grouped as well as with respect to the precision of the specifications.

In general, three approaches have been employed in writing color specifications: the naming of the desired colors; the development of color atlases which provide samples of the colors in the form of chips; a mathematical expression of the amounts of three primary colors which in combination are capable of defining all existing colors.

### Munsell System

The most widely used system of color specification in the United States is the Munsell system. Munsell wanted to develop a color notation system, illustrated by charts of measured colors, to make the recording of color easy and convenient to assist in the teaching of color to children. After initiating his work, he was contacted

<sup>8</sup> F.W. Billmeyer and M. Saltzman, *Principles of Color Technology* (New York, 1966).

by a group of retailers who wanted a standard system of colors, based on charts with numbers. This was the start of a general application of the Munsell system approach for commercial, industrial, and residential use.

Judd described the system as follows:

*The conception of the surface color solid is that each point in it represents the perception of a surface color and*

*each color just perceptibly different is represented by points separated from the first point by unit distance.*

*The scale of the solid must therefore be psychologically spaced. The unit for the lightness scale is the just perceptible difference in lightness starting with zero for black. The unit for the saturation scale is the just perceptible difference in saturation starting with zero for the gray having the same lightness as the color percep-*

*tion to be designated. Hue measurements are described in an analogous manner.<sup>9</sup>*

The determination of the appropriate "psychological spacing" in the Munsell system is based upon the ability of subjects to quantify the differences between compared colored chips, for all three attributes of color.

The Munsell system consists of five primary hues and five intermediate ones. These **hues** are further subdivided, and together with breakdowns of **value** (lightness) and **chroma** (saturation) form the other dimensions of the system. The value scale ranges from 0 (perfect black) to 10 (perfect white). The chroma scale is open-ended, but in practice often extends to 12 or 14 (depending on the ability to produce stable color chips of various hues and values). Because of the problem of instability (fading), the actual chips do not achieve all of the colors which in theory should be available.

Munsell designations may be determined by visual comparisons of color samples with the chips in the *Munsell Book of Color*. First, the page with chips of the closest hue is determined, then the colors on that page are compared with the sample being placed next to the standard chips—until the best visual match can be made.

<sup>9</sup> Judd and Wyszecki

## The Munsell Color System

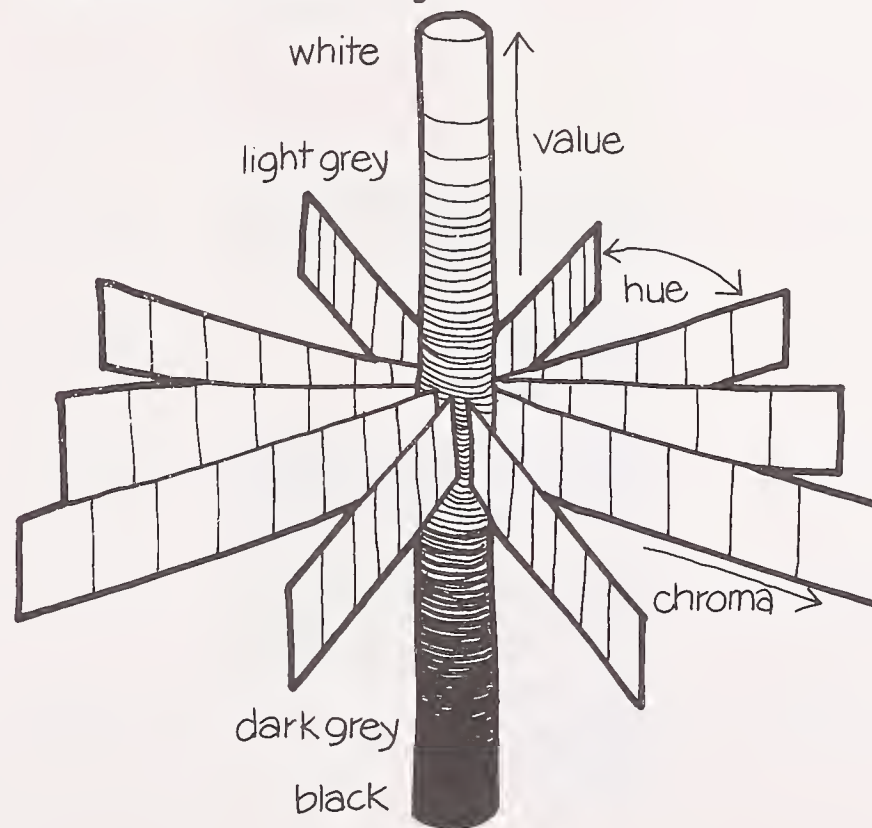

Hues are spaced around the vertical lightness axis called "value". There is an increase in saturation (chroma) with horizontal distance from the center axis to the outside of the color solid.

K. Kelly (physicist) formulated a "Universal Color Language" based most heavily on the Munsell Color System. The language was developed in recognition of the need for color designation systems having a range of precision. For example, if we were to select a color to be used to paint a wall, perhaps "light blue" would be a sufficient description to meet our needs. On the other hand, if we wanted to restore a painting to its original colors, we would want to specify the colors required with the greatest degree of precision possible.

The Universal Color Language has six levels of precision—the first three being based on names alone.

*Level 1.* The color solid is divided into 13 color name blocks—each of which contains a large range of colors. It is intended to be easy to use, employing basic hue names and the neutrals (white, gray and black). Although the hue breakdowns are not precise, the boundaries are identical with those used in levels 2 through 6. As an illustration, a carpet could be described as being brown (Br).

**List of generic hue names and neutrals and their abbreviations comprising Level 1 of the UCL. Each hue name is illustrated by an appropriate Centroid Color.\*<sup>10</sup>**

Color name	Abbreviation	Centroid Color	Color name	Abbreviation	Centroid Color
Pink	Pk		Green	G	
Red	R		Blue	B	
Orange	O		Purple	P	
Brown	Br		White	Wh	
Yellow	Y		Gray	Gy	
Olive	OI		Black	Bk	
Yellow Green	YG				

\* CAUTION: Since all the colors in this Table are photographs of Centroid Colors, they are approximations of them and so should never be used in place of the actual samples.

















<sup>10</sup> K.L. Kelly and D.B. Judd, *Color: Universal Language and Dictionary of Names* (Washington, D.C., 1976).



*Level 2.* The color solid is divided into 29 blocks; four of the Level 1 blocks being unchanged, while nine others are further subdivided. In addition to the 13 color names used previously, 16 new intermediate names are added. The intermediate names describe positions between adjacent colors in the Munsell solid. Using a Level 2 description, a carpet can be described as yellowish brown (yBr).

*Level 3.* The color solid is now divided into 267 color name blocks. The color names now account for lightness and saturation of colors, not merely the hues—thereby considerably expanding the size of the set of colors employed. The gray part of the color solid is divided into light, medium and dark parts. A carpet can now be designated as light yellowish brown (l.yBr).

**List of intermediate hue names and their abbreviations used in Levels 2 and 3 of the UCL, each illustrated with an appropriate Centroid Color.<sup>11</sup>**

Color name	Abbreviation	Centroid Color	Color name	Abbreviation	Centroid Color
Reddish orange	rO		Reddish purple	rP	
Orange yellow	OY		Purplish red	pR	
Greenish yellow	gY		Purplish pink	pPk	
Yellowish green	yG		Yellowish pink	yPk	
Bluish Green	bG		Reddish brown	rBr	
Greenish blue	gB		Yellowish brown	yBr	
Purplish blue	pB		Olive brown	OIBr	
Violet	V		Olive green	OIG	

<sup>11</sup> Kelly and Judd

Scheme of the hue modifiers, the “-ish” grays and the neutrals with their modifiers. Abbreviations are given in parentheses.<sup>12</sup>

Munsell Value (Lightness)	white (Wh)	-ish white (-ish Wh)	very pale (v.p.)	very light (v.l.)	vivid (v.)	
	light gray (l. Gy)	light -ish gray (l. -ish Gy)	pale (p.) light grayish (l. gy.)	light (l.)		brilliant (brill.)
	medium gray (med. Gy)	-ish gray (-ish Gy)	grayish (gy.)	moderate (m.)		strong (s.)
	dark gray (d. Gy)	dark -ish gray (d. -ish Gy)	dark grayish (d. gy.)	dark (d.)		deep
	black (Bk)	-ish black (-ish Bk)	blackish (bk.)	very dark (v.d.)		very deep (v. deep)
Munsell Chroma (Saturation)						

A photograph illustrating the value or lightness scale with five Centroid Colors: very light green, light green, moderate green, dark green and very dark green.<sup>13</sup>



<sup>13</sup>Kelly and Judd

A photograph illustrating the chroma or saturation scale with five Centroid Colors: gray, grayish green, moderate green, strong green and vivid green.<sup>14</sup>



<sup>14</sup>Kelly and Judd

<sup>12</sup>Kelly and Judd





The observer would compare C2 with C1 in terms of relative lightness. The colors would be directly compared and a judgment made concerning the fraction or multiple by which the lightness of C2 is related to C1. The observer has the option of recording his estimate by either numbers or linear extents (lengths of lines).  $C1=1.0$ ,  $C2=1.5$ .

An alternative procedure employed was to present pairs of chips to subjects (C1 and C2) to be compared with other pairs (C3 and C4) and the differences between pairs are estimated in terms of ratios—in the same manner as above.

#### Natural Color System

An alternative to the Munsell approach for ordering colors is the Johansson ("Swedish") Natural Color System.

Johansson was interested in developing a theory of color composition which produces aesthetically pleasing results. His work was later used by Swedish industries manufacturing colored materials. Johansson's system like the Munsell System is represented by an atlas of colors. Johansson indicated that *A colour system, which is to be a basis for studies in color aesthetics must use only attributes of visual color perception, i.e., such attributes of a color which could be experienced and evaluated solely with the help of the color sense of a human being.*<sup>16</sup>

This system is designed to describe colors and color relations quantitatively in terms of somewhat different characters (qualities) of the perception than those used by Munsell. The samples within the *Munsell Book of Color* are intended to be equally spaced along the perception scales, but the spacing between samples of the Natural Color System is not intended to be constant.

Unique color perceptions are described on the basis of a **lightness scale** and a **hue circle**. The lightness scale ranges from white to black with shades of gray between.

The basis of the quantitative definition of hue in the Natural Color System is the ratio of the primary colors seen as contributing to the hue of any sample. Thus, all reddish orange colors perceived as, for example, 60% red and 40% yellow, are regarded as having the same hue, regardless of lightness or color strength. It has been found in work in Sweden that subjects can make these percentage estimates of color content with satisfactory consistency.

*Among colors of constant hue, the natural reference points for the color strength scale, are the color of maximum color strength (an imaginary color which is absolutely chromatic) and the neutral color of the same lightness. Thus the color strength scale can be illustrated with a straight line from neutral to the "maximum color."<sup>17</sup>*

*The hue circle is the scale for constant visual hues, usually represented by the colors of maximum color strength in each hue. Wherever this scale starts it will return to this starting point and may thus conveniently be shown as a circle. The unique perceptions of the hue circle are the four primary hues which are neither-nor hues. They are the yellow (Y), (which is neither greenish nor reddish), the red (R), (neither yellowish nor bluish), and the green (G), (neither bluish nor yellowish), and blue (B), (neither reddish nor greenish). Between these primary hues lie the hues that are both. Orange is both a yellow and red color, etc.*

*When hue character is illustrated in the color circle, it seems natural to situate yellow and blue opposite each other as both are neither greenish nor reddish, and green opposite red as both are neither yellowish nor bluish. By using this method of illustration we arrive at the symmetrical color circle.<sup>18</sup>*

All colors of constant hue can be arranged in a diagram along the two remaining parameters of lightness and color strength. Other attributes such as cleanness and saturation can be expressed in terms of these three parameters.

The quantitative details of the Natural Color System are still evolving, on the basis of work still in progress in Sweden. Judd and D. Nickerson (physicist) believed that with minor adjustments, the Natural Color System could be brought into a one-to-one correspondence with the Munsell system. They have published formulas giving the correspondence between the different variable sets of the two systems.

<sup>16</sup>A, Hard, "NCS: A Descriptive Colour Order and Scaling System with Application for Environmental Design," *Man-Environment Systems*, 5 (1975).

<sup>17</sup>Hard.

<sup>18</sup>Hard.

#### Color Attributes— Natural Color System

---

##### Hue:

One color being yellower, greener, etc. than another one.

---

##### Lightness:

One color being lighter than another one.

---

##### Color Strength:

One color being more intense than another.

---

##### Cleanness:

One color is dirtier, the other one, cleaner.

---

##### Saturation:

One color is paler, the other one, deeper.

---



E. Berglund (Swedish researcher) describes an application of the Natural Color System. Participants start with a large number of color samples which are sorted into five groups: neutral (black, gray, white), yellowish, reddish, bluish, and greenish. These groups are then further analyzed. For example, the samples in the yellowish group are divided into three further groups—pure yellow, greenish yellow, and reddish yellow. (The same procedure is followed for the other colors.) The colors are then arranged in a circle with the four primary colors as fixed points. The final step is to develop a constant hue chart.

Another study by Berglund using the Natural Color System is described below:

Samples were produced as series of 15 painted cards in the size of 6 x 10 cm. The cards had a semimatte finish and were viewed under approximately 45° normal geometry in artificial daylight, here represented by a suitable arrangement of cubes. For each of the unique hues three such series of colored cards were produced, where as far as possible only the attribute of hue varied with each series. One of the three series (A) showed very light, unsaturated but clean colors. The second series (B) showed colors of moderate to high saturation but still as clean and unshadowed as possible. In the third series (C) all colors were moderately saturated and dull.<sup>19</sup>

<sup>19</sup>E. Berglund, *Applications of the Natural Colour System* (Stockholm).

## Studies of Color in Buildings

Our discussion of color has surveyed several general methods of classifying and measuring colors, but studies directly concerned with buildings have been rare. We will now describe a few such investigations.

R. Kuller (Swedish psychologist) performed two studies to find out the influence of color on the perception of a room. In the first investigation, he used color slides of a perspective sketch of a room. The interior details of the room (e.g., furniture, curtains) were varied in terms of their colors, while the room itself was in black and white. Kuller found that color greatly influenced the responses of subjects, as measured by a semantic rating scale.

### Perspective Sketch of Room (Küller)

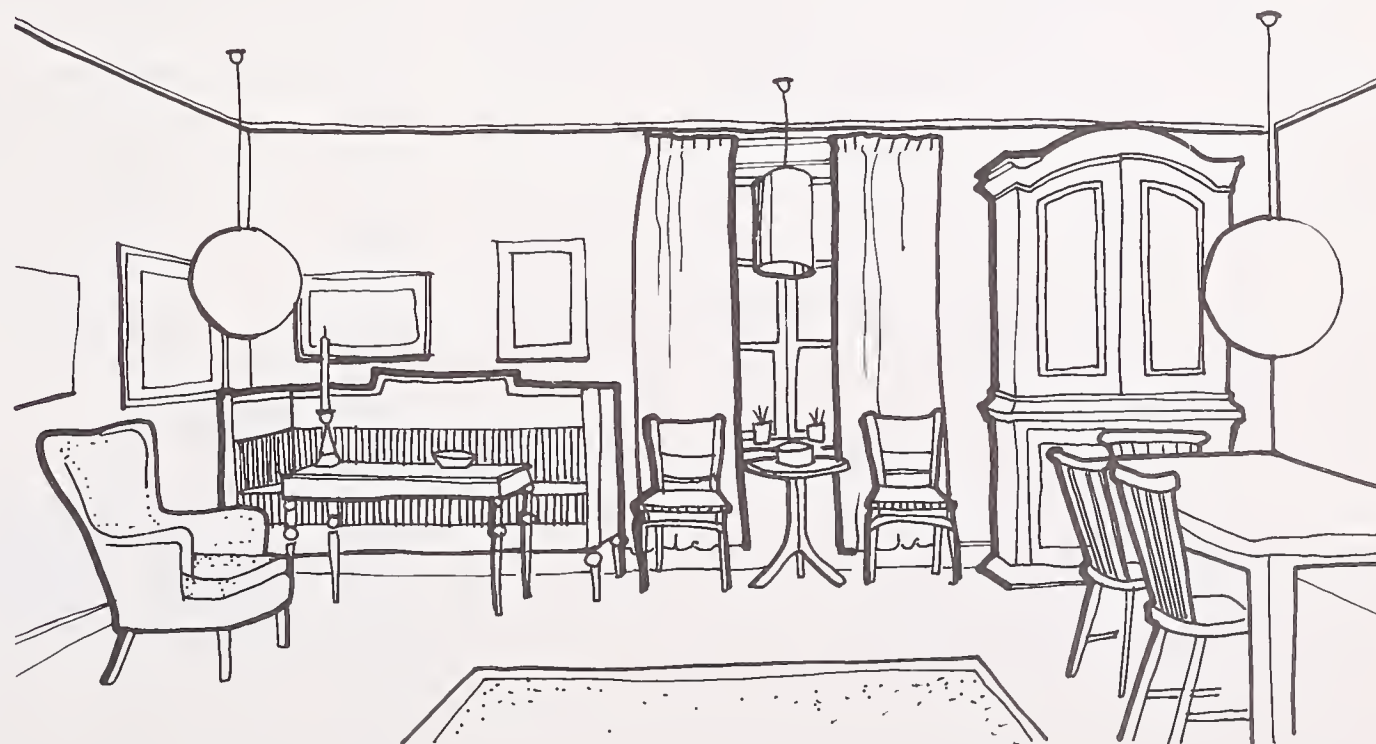

His next study was designed to find out if people responded comparably when only the walls were colored. The hues employed were yellow, green, red, and blue, and, four intermediate ones in the Natural Color System. They were varied in terms of lightness and chromatic strength.

When we think of how colors effect our perception of the environment, aesthetic concerns come to mind first. Colors are said to influence our feelings as in the case of "warm" or "cool" environments. However, there is a considerable gap between experimental evidence showing such effects and opinions stating the effects to be real ones.

The effect of color on feelings of warmth was tested by F. Houghton (research engineer) et al. A canvas screen 6 ft. x 6 ft. (1.8 m) was placed at one end of a room 17 ft. x 8 ft. (5.1 m x 2.4 m). A 1000-watt projector at the far end of the room produced a lighted area approximately 5 ft. 4 in. (1.6 m) in diameter. Subjects viewed the screen under three conditions—with white light, and with the light produced by using a red and then a blue filter in front of the projector lens. The subjects viewed each of these conditions for an extended time, usually 40 minutes or more.

The responses were physiological—skin and oral temperature and pulse rate were monitored and environmental conditions were carefully controlled (77° dry bulb temperature, 50% relative humidity). Observers rated their feelings of warmth on a scale with 4 as "ideal," 2 "cool" and 6 "warm." The ratings remained 4 under all conditions, with no evidence that color had any effect on perceived warmth.

### Results of Rating Scale (Küller)

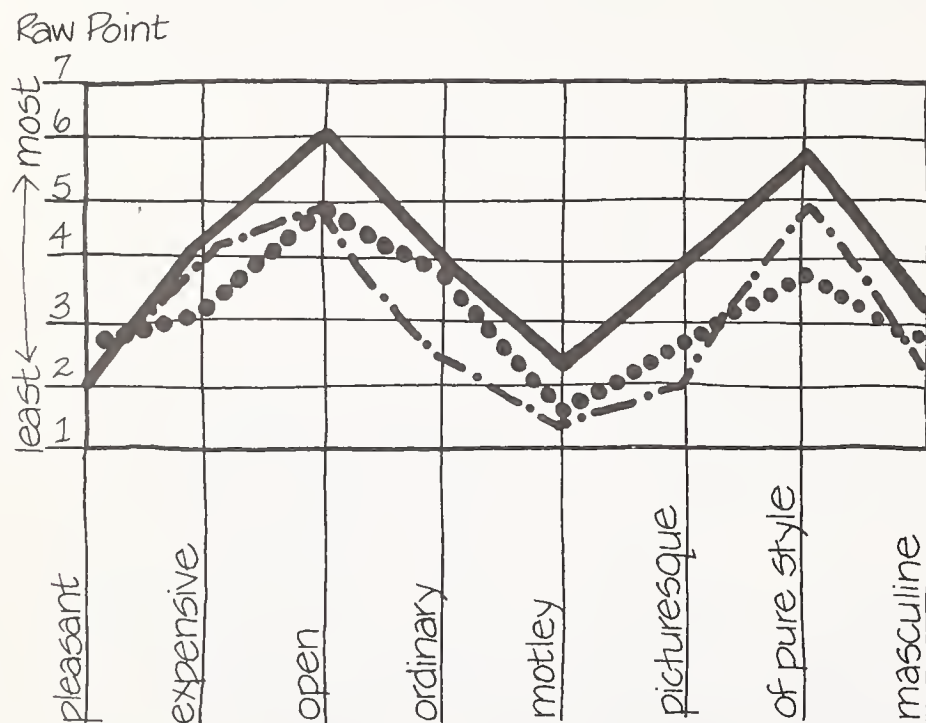

- the room in colourphoto (estimation by college students)
- · - · uncoloured drawing of room (estimation by architecture students)
- uncoloured drawing of room (estimation by chemistry students)

### Effect of Color on Feelings of Warmth (Houghton et. al.)

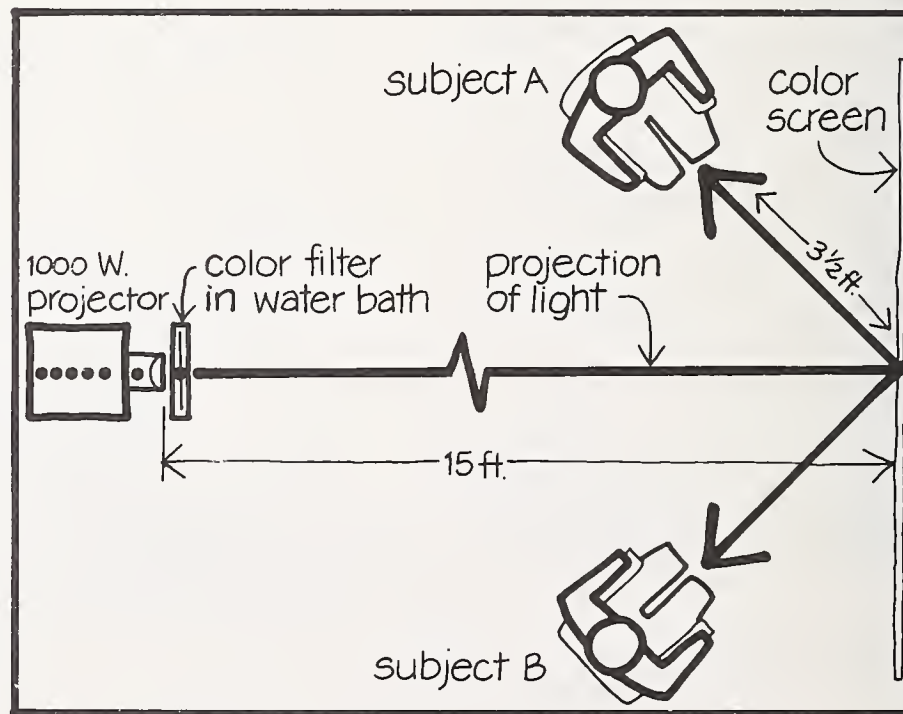



Another study designed to measure the reaction of subjects to room colors was performed by I. Payne (architect). He measured pupil size as a means of determining how people respond to colored stimuli. In his first experiment, he measured the response of six architects and six non-architects to a series of color slides: two pictures of the interior of a contemporary building, the exterior of an historic building, and a non-architectural picture (flowers). Pupillary responses were recorded with a 16-mm camera. Each slide was presented for 5 seconds and each individual's response was related to his response to the first slide, a blank gray slide of the same intensity as the others. The results indicated that the subjects reacted more positively to the color slides than the gray ones, with architects reacting to a greater degree than non-architects.

The second experiment performed by Payne consisted of slides of model rooms which varied in color (red, blue, and white) and complexity (a simple room and a complex room). The simple room was an empty space with scale furniture and the complex room was the same cube with additional horizontal and vertical planes. The results indicated pupillary response order to be red-white-blue, with red creating the most positive reaction (widest pupil response).

Plan of Pupillary Apparatus (Payne)

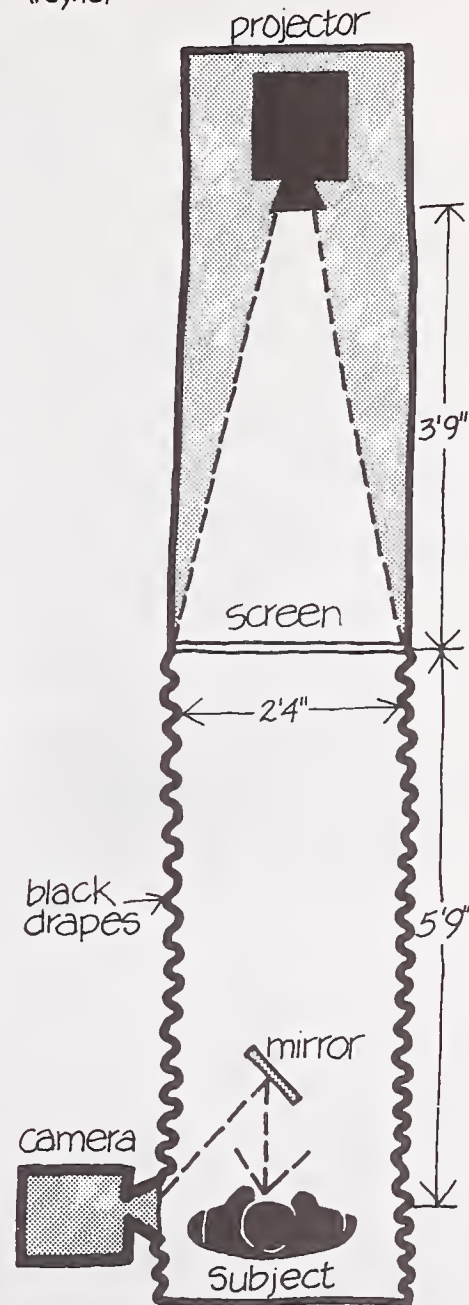

While Payne investigated responses to color by physiological means, M. Inui (Japanese lighting engineer) conducted a general building survey to determine the colors most often used. He examined 381 rooms in several building types (movie theatres, hotels, hospitals, schools, and dwellings). He classified the colors of ceilings, floors, walls, and doors using Munsell color chip samples, examining 2,139 colors in all. While his sampling procedure was not carefully controlled, the research approach is an interesting one.

### Conclusion

This brief review of color suggests that M/E researchers have only begun to examine the effects of color on people in buildings. Researchers can offer limited suggestions, supported more by basic findings, rather than by studies performed in buildings, or simulations of them. This is not to say that building color requirements cannot be researched, only that the subject has received limited attention. The energy crisis may provide the impetus required

to better understand the role of color in buildings. The popularity of high efficiency light sources (which in some instances have undesirable color rendering properties), has made many people increasingly aware of color as an important environmental attribute. This attention may provide the impetus to conduct research to better understand color perception from the standpoint of building users.

We have reviewed several research approaches and requirements dealing with the auditory and visual environments. While many different methods of study were described, they are predominantly parametric laboratory investigations. Studies of the effectiveness of illumination in occupied buildings are difficult to find as are evaluations of acoustical designs. From the standpoint of performance activities, a major effort is required by M/E researchers to test and validate laboratory based findings under actual use conditions. In this way, design guidelines can be evaluated and improved in an orderly way.

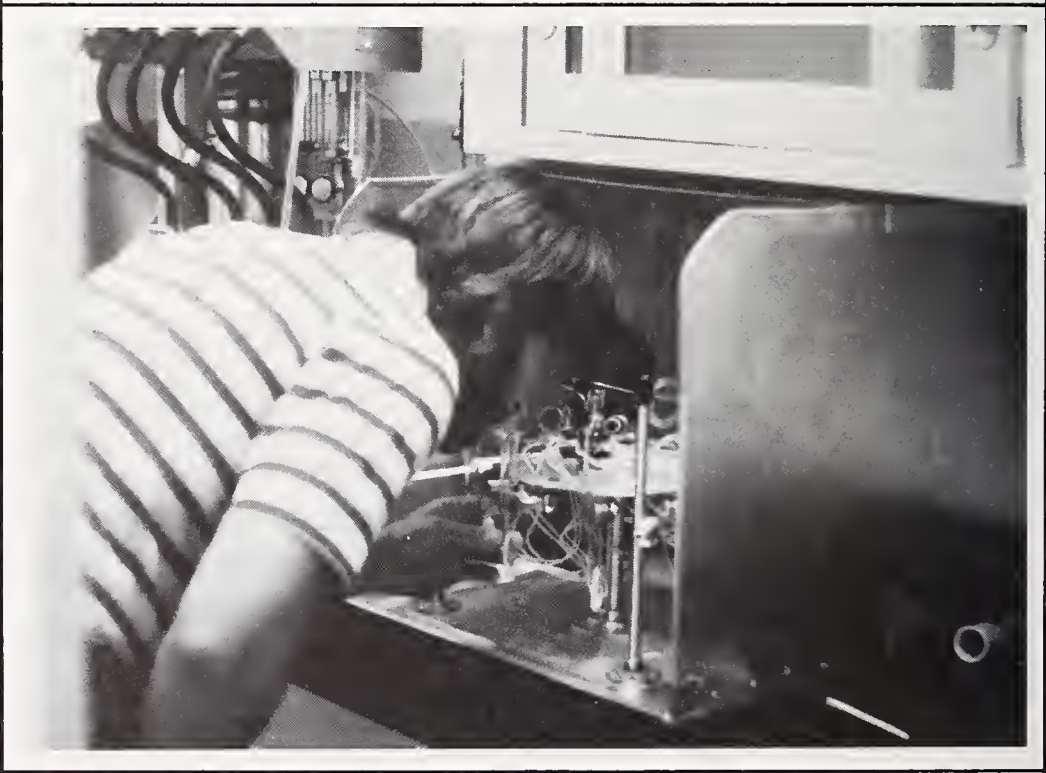
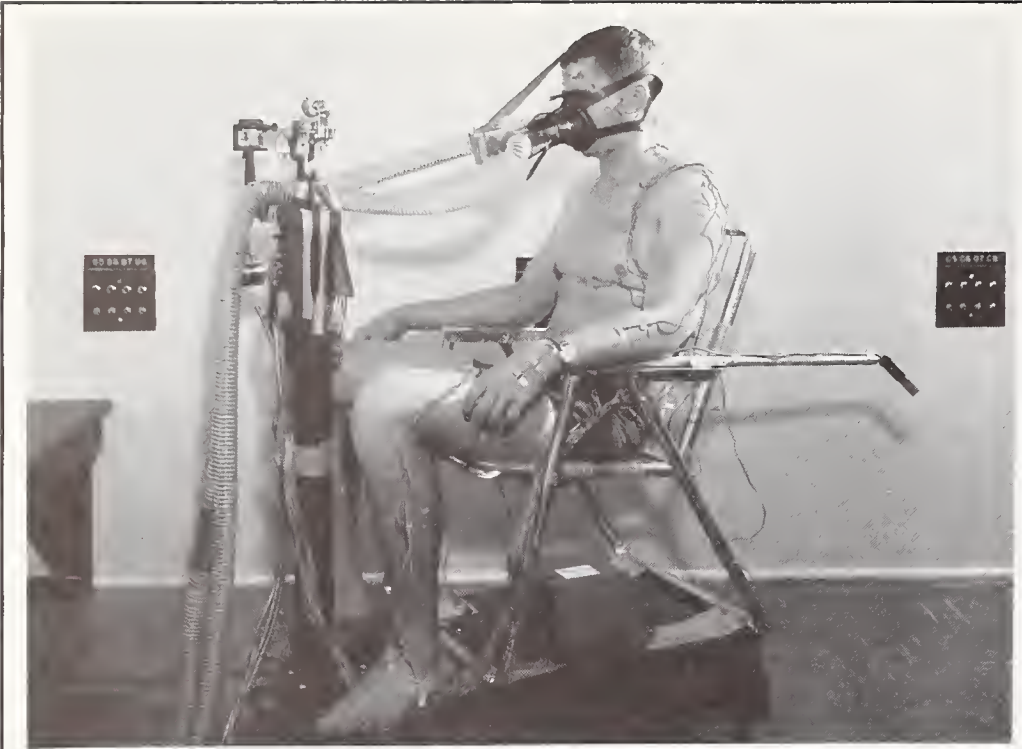



# Part V

## Less Explored Senses

*It goes without saying that all architects aspire to the creation of beautiful buildings. But a fundamental weakness in most discussions of architectural esthetics is a failure to relate it to its matrix of experiential reality. Our whole literature suffers from this conceptual limitation since it tends to divorce the esthetic process from the rest of experience, as though it were an abstract problem in pure logic. Thus we persist in discussing buildings as though their esthetic impact upon us were an exclusively visual phenomenon. And this leads immediately to serious misconceptions as to the actual relationship between the building and its human occupants. Our very terminology reveals this misapprehension: we speak of having seen such and such a building, of liking or not liking its looks, of its seeming too large or too small in scale, etc., etc. These are all useful terms, of course, insofar as they convey a part of the whole truth about our relationship to our buildings. But they are also extremely misleading in suggesting that man exists in some dimension quite separate and apart from his buildings; that his only relationship with them is that of passive exposure; that this exposure occurs only along the narrow channel of vision; and that the whole experience is quite unaffected by the environment in which it occurs.*

*The facts are quite otherwise and our modes of thought must be revised to correspond to them. For architecture—like man himself—is totally submerged in the natural external environment. It can never be felt, perceived, experienced, in anything less than multidimensional totality. A change in one aspect or quality of this environment inevitably affects our perception of and response to all the rest. Recognition of this fact is crucial for esthetic theory, above all for architectural esthetics. Far from being narrowly based upon any single sense of perception like vision, our response to a building derives from our body's total response to and perception of the environmental conditions which that building affords. It is literally impossible to experience architecture in any "simpler" way.<sup>1</sup>*

<sup>1</sup> J. M. Fitch, *The Architectural Manipulation of Space, Time, and Gravity* (New York, 1969).

Le Corbusier stressed the importance of human scale in design. (The size of the body being the natural "yardstick" by which we perceive our surroundings.) By using this analogy, Le Corbusier acknowledged the pre-eminence among architects of visual attributes in design, and at the same time contributed to an even greater emphasis of them. Buildings do not serve only visual functions. Rather, they have the potential of stimulating all of our senses and cannot avoid having an impact on several of them. The architect therefore designs spaces and volumes which are in fact perceived not only visually but by means of other sense modalities as well. The non-visual aspects of buildings, with the exceptions of the acoustic and thermal environments, have received little attention by M/E researchers and merit serious research and design consideration because of the actual and potential importance to building occupants. The present part of this work describes research studies dealing with these environmental factors.

With the exception of work dealing with thermal comfort, it will become apparent that the sensory information needed by architects is simply not available for the most part, nor are the research procedures to develop the required data available.



*Study of Thermal Comfort (F. Rohles)*



# 14

## The Thermal Environment

Laboratory Studies  
Performance Measures  
Observational Studies  
Field Studies  
Asymmetrical Heating  
Conclusion

---

*It seems not so long ago when environmental studies were focused on the prescription of minimum temperatures and problems of underheating.*

*The 'modern' lightweight building of that type that has become characteristic of many schools, hospitals and offices is well equipped to generate enough heat to overcome thermal losses, but, since it has large glass areas and is of lightweight construction, it tends to be thermally unstable. Having little thermal storage capacity it responds rapidly to solar inputs while the large glazed areas emphasize the 'greenhouse effect.' In addition, it is poorly equipped with regulatory controls—radiators and convectors are relatively insensitive to temperature changes and convectors have extremely poor feedback characteristics.*

*The study of overheating has thus generated new thinking about the nature of thermal comfort, replacing the older, passive model which equated comfort with physiological neutrality, by an active model of a self-regulatory system in open-ended interaction with the physical environment in forms governed by social constraints. In the course of such a change, it goes without saying that single values are replaced by ranges of temperatures and other variables. The final outcome of such studies is not only to produce a new theoretical model of the thermal environment but to direct attention to control mechanisms as part of the feedback loop, whether these be more responsive window and ventilation controls, more sensitive thermostats and sensors...<sup>1</sup>.*

---

<sup>1</sup> F. J. Langdon, "Human Sciences and the Environment in Buildings," *Build International*, 6 (Jan-Feb 1973).

The call for energy conservation has highlighted the importance of the thermal environment. While studies of thermal comfort date back more than half a century, most design data were collected under a narrow range of conditions which might limit their applicability under actual use conditions. For the most part, studies have been performed under well-controlled laboratory conditions with subjects not performing meaningful activities.

Historically, buildings have been described in terms of their adequacy in serving as a shelter, providing protection against extreme climatic conditions. Buildings therefore serve as climate modifiers, to accommodate the needs of their occupants, first physiologically (for survival), and then to accommodate the activities performed by them.

Architects are not really faced with the problem of determining the thermal requirements necessary for survival. Folk wisdom, scientific findings, and the inherent adaptability of people have all played a role in overcoming this basic necessity. Of particular importance has been the range of available solutions, from wearing appropriate clothing to employing energy to modify environmental conditions.

However, design for survival only is certainly not sufficient today. How *should* the thermal environment be designed? What are the optimum conditions for people engaging in activities within buildings? Although answers to these questions have been provided, we believe that the problems have not been adequately solved because of shortcomings in the methods used as a basis for design recommendations. These will be examined later.

The thermal properties of buildings have received increasing attention in recent years, with the advent of the "energy crisis." The major energy requirement for buildings is for heating and cooling. Consequently, it is not surprising that when seeking ways to conserve energy, many people are looking toward the thermal attributes of the building as a potential source of saving. More particularly, a number of recommended solutions are directed toward asking building occupants to adjust to environmental conditions considered less than optimum. For example, one recommended approach is to lower temperatures in buildings during the winter season, and ask people to wear heavier clothing as a means of attaining comfort.

Past design practices have contributed to the scope of the problem faced by those seeking to save energy in buildings. Total dependence on forced air conditioning and circulation in sealed buildings (having un-openable windows) appeared to be a logical approach when energy was inexpensive and abundant. Now, buildings designed in this manner pose a problem for those concerned with saving energy. For example, many energy conserving approaches are heavily dependent on the traditional concept of considering a building shell as a permeable membrane. Windows can serve the energy saving function of permitting outdoor climatic conditions, when favorable, to reduce energy consumption, e.g., opening the windows during evening hours in the summertime to dissipate the unwanted accumulated heat load in a building. Windows can also be used to ventilate the building using natural breezes for air movement. Defining an appropriate thermal environment, therefore, has implications for both building occupants and energy usage.

Research concerned with specifying environmental conditions for survival can be traced back many years. For example, the development of submarines and high altitude aircraft necessitated the design and construction of vehicles which not only sustain life but permit activities to be performed. More recently, space age technology has accelerated the development of information required for man to survive and function. When defining such environments, many

characteristics are taken into account, but none more important than those which provide acceptable thermal conditions.

Military and space research activities have focused on determining the environmental limits of man, i.e., the upper and lower limits of toleration, in terms of: (1) life safety and (2) the performance of activities. On the other hand, researchers responsive to the needs of architects have examined thermal comfort, using relatively moderate ranges of temperatures to define the desirable thermal environments of buildings.

Early studies of thermal comfort were designed to obtain response measures which were subjective and physiologically based. Body and skin temperatures, pulse and sweat rate were among the physiological measurements taken. Subjects were also asked to evaluate the environment using verbal and numerical scales. While traditional investigations have been performed in laboratories, in recent years there has been an increasing emphasis on conducting research in actual buildings while typical activities are being performed. Still another approach has been to combine the features of laboratory and field investigations.

The goal for those studying the effects of the thermal environment on people is often stated in one of two ways. It is to describe environmental characteristics which produce:

- *Thermal comfort*, defined as that condition of mind which expresses satisfaction with the thermal environment, or

- *Thermal neutrality*, defined as the condition in which a person would prefer neither warmer nor cooler surroundings.

As with the auditory area of research, the approaches concentrate on preventing feelings of discomfort, rather than on how to produce a positive response to thermal conditions, e.g., interesting, invigorating.

The classic studies of F. Houghton and C. Yagloglou (engineers), which started more than half a century ago,

have provided the general framework for laboratory studies since that time. Their research rationale underlies most thermal comfort studies available today:

*The bodily feeling of warmth is not due alone to the temperature indicated by the dry bulb thermometer, neither does it depend solely upon the wet bulb temperature. Dry air at a relatively high temperature may feel cooler than air of considerably lower temperature with high moisture content.*

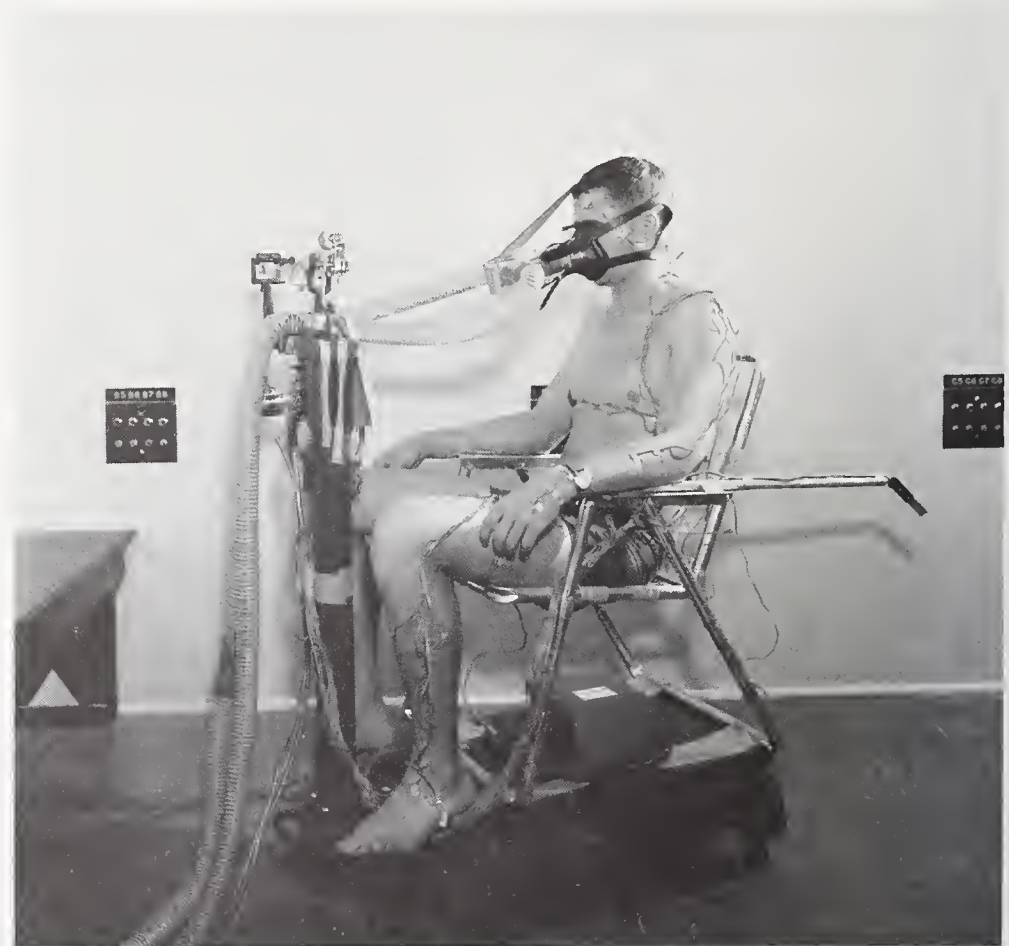

*Physiological Measures of Thermal Comfort (F. Rohles)*



Human comfort or discomfort depend largely on the relation between the rate of heat production and dissipation. By the process of metabolism heat is constantly generated within the body, while on the other hand, loss of heat is constantly occurring from the surface of the body by radiation, convection and evaporation. To maintain a constant body temperature the loss of heat must equal the heat produced. It is therefore apparent that any interference with the elimination of heat from the body is accompanied by a rise in temperature and a feeling of discomfort.

There are three principal factors affecting loss of body heat:

1. Temperature.
2. Humidity.
3. Air motion.

As the temperature of the air and surrounding objects rises, the loss of heat by convection and radiation decreases. When the temperature reaches that of the body, the loss by radiation and convection ceases. Finally, as the air temperature exceeds that of the body, heat passes from the air to the body.

If, on the other hand, the relative humidity is increased the heat loss by evaporation decreases. If while the dry bulb temperature increases, the wet bulb temperature decreases sufficiently, the increase in the loss of heat by evaporation may be made equal to the decrease in the loss of heat by radiation and convection, resulting in no change in the thermal state of the body temperature or comfort.

From the above, it is concluded that there must necessarily be certain combinations of temperatures and humidities, which produce the same total body heat loss by radiation, convection and evaporation and therefore the same feeling of comfort or discomfort. Lines passing through such air conditions may be called equal comfort lines. The fact is further substantiated by the general experience of heating engineers in observing that the lower the humidity the higher the temperature required for the same degree of comfort. Determining these equal comfort lines for various temperatures, humidities and air velocities is the object of an important investigation being carried on at the Research Laboratory.<sup>2</sup>

### Representative Values for Heat Production at Various Activities (From Canter)

Activity	Heat Production* W/m <sup>2</sup>
Basal metabolism	45
Seated at rest	60
Standing at rest	65
Office work	75
Walking on level ground	
at 3.2 km/h	115
at 8.0 km/h	340
Heavy manual work	250
Digging	320

\* Metabolic Heat Production per unit surface area, W/m<sup>2</sup>

<sup>2</sup> F. C. Houghton and C. P. Yagloglou, "Determination of the Comfort Zone," *ASHVE Transactions*, 29 (1923).

Later work by Houghton and Yagloglou and their successors in the following decades has also shown the importance of clothing and activity on thermal responses to building environments.

### Comfort Line by Nevins (Fanger)

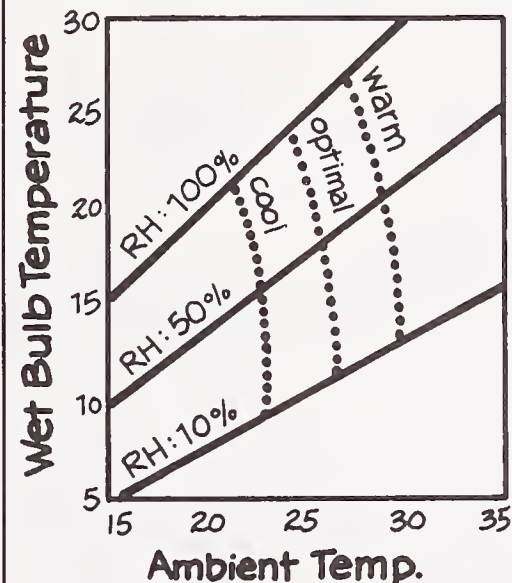

The line shows different combinations of ambient temperature and humidity which will provide optimal thermal comfort for sedentary persons.

### Laboratory Studies

The influence of the early work by Houghton and Yagloglou has been so great that the variables examined and the methods that they developed form the basis for most studies being performed today in this research area. Their investigations were designed to establish and define a comfort zone in terms of the variables comprising "effective temperature," namely air temperature, velocity, and relative humidity. In their studies, they used male subjects, sometimes fully clothed, in other instances stripped to the waist. The subjects entered the first of two adjoining rooms, which differed from one another in terms of one or more of the variables indicated above. They remained in the first room for either one-half or one full hour. Afterward they entered the second room. The conditions of wet-bulb and dry-bulb temperatures were adjusted in the second room until subjects reported that the rooms were equal in warmth or coolness. From these studies, they derived lines of equal comfort which still form the basis for accepted thermal performance of buildings in the United States—ASHRAE criteria. The investigators also made physiological measurements—pulse rate, weight loss, and increase of body temperature.

## Effective Temperature (ET) (ASHRAE)

ET °C	Temperature sensation	Discomfort	Regulation of body temp.	Health	ET °F
40	Very hot	Limited tolerance Very uncomfort.	Failure of free skin evaporation	Increasing danger of heat-stroke	100
35	Hot	Uncomfortable	Increasing vasodilation sweating		90
30	Warm	Slightly uncomfortable			80
25	Slightly warm	Comfortable	No registered sweating	Normal health	70
20	Neutral	Slightly uncomfortable	Behavioral changes	Complaints from dry mucosa	60
15	Cool	Uncomfortable	Shivering begins		50
10	Cold				
	Very cold				

Possibly the most comprehensive investigation of thermal comfort was performed by F. Rohles (psychologist). The test subjects in the study consisted of 800 male and 800 female college students ranging in age from 18 to 24. A total of 160 experimental conditions were examined—8 relative humidities (15% to 85%) and 20 dry-bulb temperatures (60 °F to 98 °F) (16 °C to 37 °C). Ten subjects, five men and five women, participated in each test condition. Different subjects were used for all conditions.

The tests were conducted in an environmental test chamber consisting of: a main chamber 12 ft. (3.7 m) wide, 24 ft. (7.3 m) long with an 8 ft. (2.4 m) ceiling; a pretest room 9 ft. (2.7 m) wide and 18 ft. (5.5 m) long; a control room. All subjects wore cotton twill shirts and trousers.

Subjects reported to the pretest room where temperatures ranged from 75 °F to 78 °F (24 °C to 26 °C). They were read instructions about the study and told how to rate their thermal sensations. After approximately 30 minutes, the subjects entered the main test chamber. They sat at tables and were permitted to read, talk, or play cards. The study lasted 3 hours, and the environment was rated at 1.0, 1.5, 2.0, 2.5, and 3.0 hour intervals. The rating sheets were collected after each rating period.





Standard Uniform (F. Rohles)

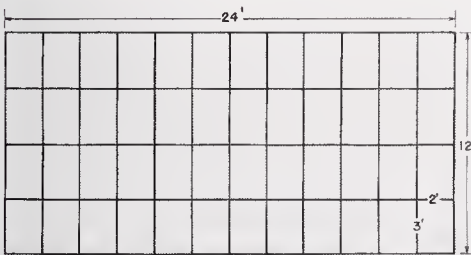

Thermal Comfort Laboratory (F. Rohles)

The results of the study by Rohles led to an examination of the scale used to rate the environment, which combined thermal sensation (e.g., cool, warm) with a comfort rating (comfortable). Later ASHRAE studies employed two scales to obtain separate ratings of "sensation" and "comfort."

### Thermal Comfort Evaluation (Rohles)

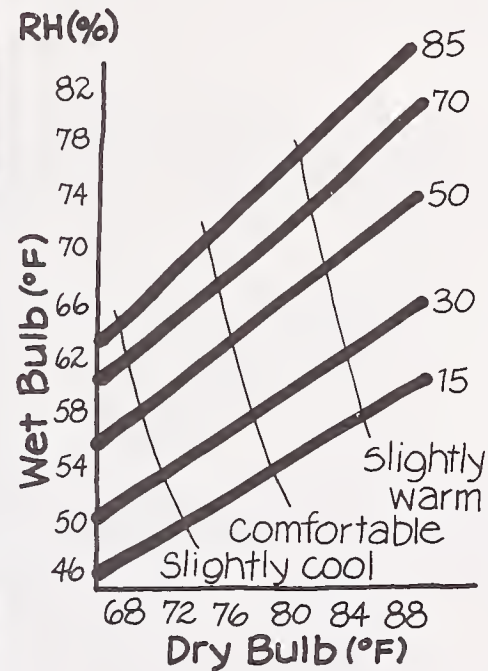

Lines of thermal sensation for men and women combined after an exposure of 3 hours.

The ability to perform activities is generally important in M/E studies. In thermal comfort work, this factor is especially significant. This is because activities require different levels of effort (i.e., the heat produced by a person performing an activity), which influence the balance of bodily heat production and dissipation—a major influence on feelings of thermal comfort.

### Insulation Values of a Variety of Clothing Ensembles (From Canter)

Clothing	Insulation
Light sleeveless dress, cotton underwear	0.2
Light trousers, short sleeve shirt	0.5
Warm long sleeve dress, full length slip	0.7
Light trousers, vest, long sleeve shirt	0.7
Light trousers, vest, long sleeve shirt, jacket	0.9

A goal of researchers has therefore been to develop a standardized procedure to define levels of activity, measured by heat production. P. McNall (engineer) et al. describe such a procedure in a study of temperature, humidity, and activity levels. The study was performed in a way similar to that described in the Rohles study. The activity levels were achieved by having subjects walk up and down for 5-minute periods on two 4 in. (10 cm) steps. The rates of walking speed were varied to accomplish the three metabolic rates—600, 800, and 1000 Btu/h.

### Thermal Comfort Work Study (McNall et al.)

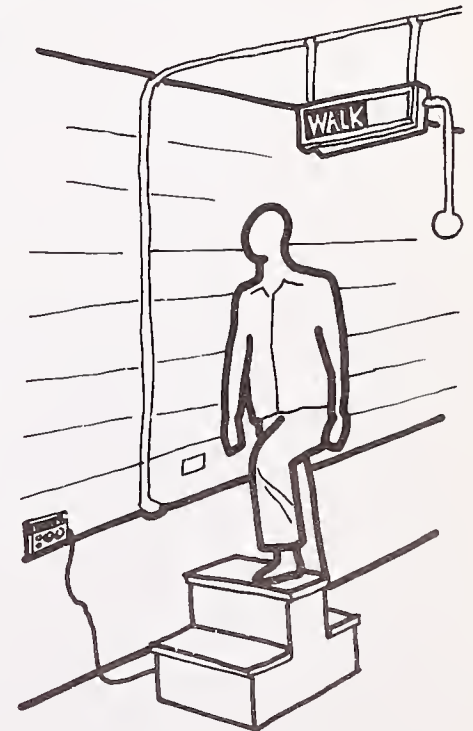

Male subject during 5 min. walk period on two 9" steps

## Comfort Votes for Four Activities (Nevins and McNall)

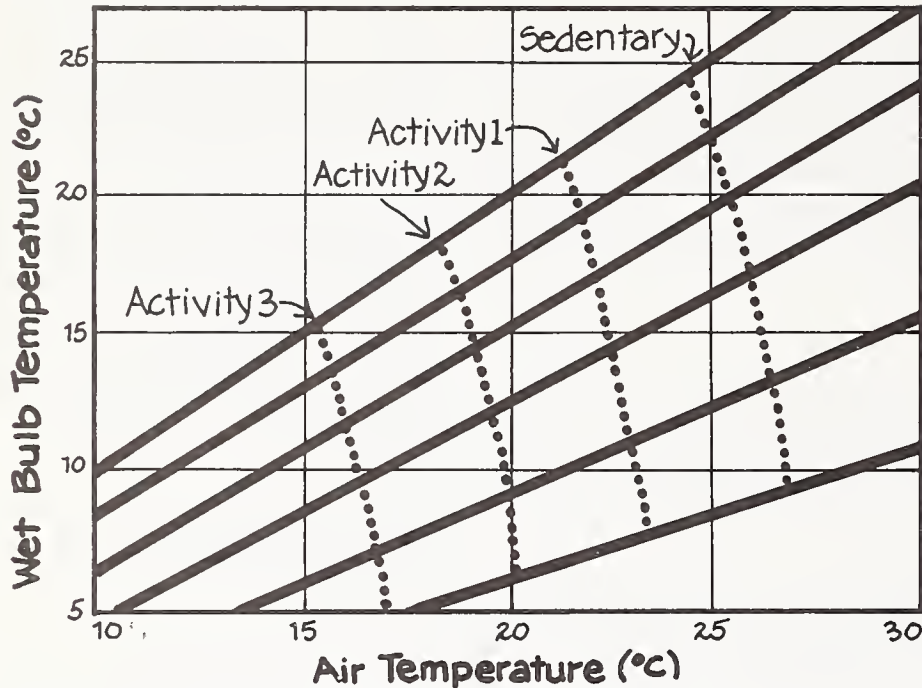

Comparison between the comfort equation and the results of Nevins and McNall. The curves are comfortlines corresponding to four different activities.

— Nevins and McNall ..... Comfort equation

In contrast to the ASHRAE research approach, where several subjects participate simultaneously under environmental conditions specified by the researcher, P. Fanger (Danish engineer) conducted extensive laboratory studies in another way. Fanger's experimental technique is described in one such study by Fanger and B. Olesen, concerned with skin temperature distribution for a resting person. Thirty-two subjects (16 males and 16 females) took part in the study, one at a time. Each subject wore a harness on which 14 heat measurement devices (thermistors)

were attached. The thermistors were taped to the skin in the locations specified in the accompanying figure. A standard cotton twill uniform was worn in the environmental chamber.

At the start of the study, the temperature was set at 25.6 °C, based on earlier studies by Fanger defining thermal comfort. The ambient temperature was then varied in accordance with the *desire* of the subject, who was asked at 10-minute intervals whether adjustments (warmer or cooler) should be made. The subject was encouraged to request very small changes if desired. Male and female subjects preferred similar

temperatures. In addition, the only region where males and females differed significantly in their local skin temperature was on the feet, the feet temperatures of females being 2.10 °C lower than that of males.<sup>3</sup>

Finally, in the case of one subject, a skin temperature distribution was obtained by means of thermography. This subject was tested and photographed in the nude.

Fanger later refined his method of obtaining thermographic records of subjects, which he describes in the

following way: Basically, the subject is photographed from many different directions. A fixed camera is used, with mirrors mounted around the subject. A large number of photographs is then taken of each subject and each photograph is planimeted. Subjects are photographed seated and standing, nude and clothed. Each photograph then provides the projected area of the body for a given viewing angle. When the projected area of the body is known for an adequately large number of angles, the desired data for the human body is then calculated.<sup>4</sup>

## Predicted Percentage of Dissatisfied (PPD) as a Function of Predicted Mean Vote (PMV) (Fanger)

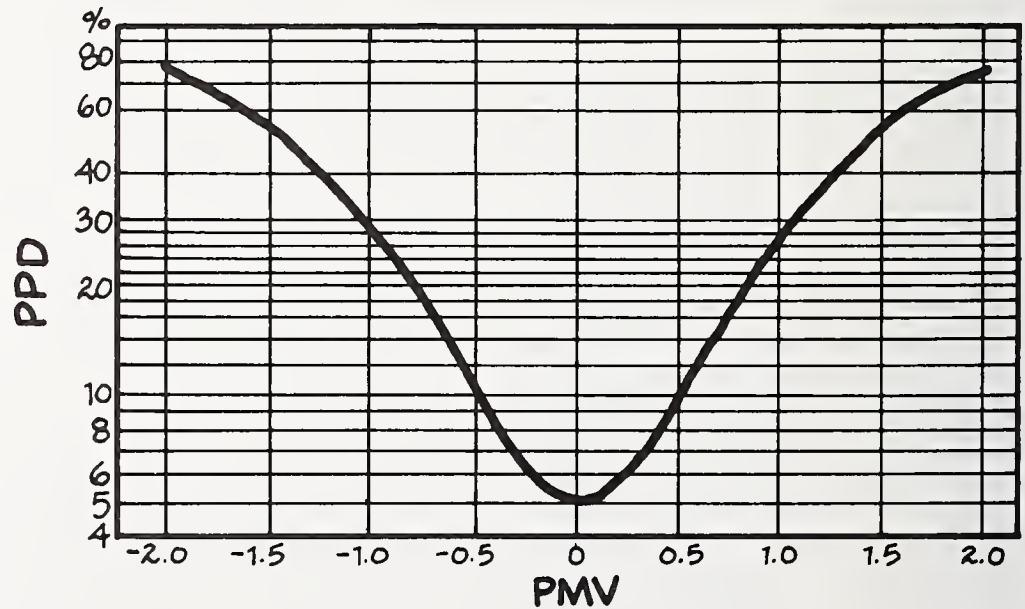

<sup>3</sup> P. O. Fanger, *Thermal Comfort* (Copenhagen, 1970).

<sup>4</sup> Fanger



## Performance Measures

The most direct way of finding out how temperature or other environmental conditions affect the ability to perform an activity is to vary the environment, e.g., room temperature, in an orderly way and determine the consequences, measured in terms of performance.

Studies of this type date from the time of the Hawthorne investigations performed in the 1920's and 1930's (see chap. 19). More recently, human factors researchers since World War II have intensively examined task performance, primarily under extreme environmental conditions. At the same time, industrial psychologists have developed a multitude of standardized tasks and psychological tests for job selection and performance evaluation purposes.

D. Wyon (psychologist) has been a strong advocate of the need to include performance measures in M/E studies. In several studies, he has used measures of performance in conjunction with other methods of evaluating how subjects respond to thermal conditions. An illustration of his approach is an investigation carried out in a climatic chamber. Thirty-two subjects, 16 male and 16 female, participated separately in a 5-hour experiment, wearing standardized uniforms. Room temperatures were varied while several different types of measurements were made:

- physiological (body temperature, weight),
- subjective judgments (semantic differential),
- performance tests (numerical, word memory, typing).

One measure of performance was the score achieved on a task of adding sets of five 2-digit numbers. Subjects were paid on the basis of their accuracy. Another test was concerned with word memory. A list of 25 common words was shown to subjects. Later a list of 50 words was presented, and the task was to identify words from the earlier list of 25, which appeared on the test list. Wyon has found that the ability to perform several tasks was impaired at temperatures of 27 °C and above.

## Observational Studies

Since the thermal resistance of clothing has an important effect on thermal comfort, clothing cannot be ignored in such research. The traditional way of dealing with clothing has been to standardize it in laboratory studies. For example, all subjects participating in a study would wear a standard uniform, having known thermal resistance properties. Clothing would then be a "control" variable—one which would be fixed for all experimental conditions.

Clothing has also been used as a dependent variable or response measure in a field study of classroom behavior. M. Humphreys (British physicist) studied thermal comfort in a classroom, by keeping a record of the clothing worn by children aged 11 to 17, during the months of May through July. Boys and girls wore traditional uniforms to school, and were able to remove or add items of clothing at their discretion during the school day. Humphreys used a time-lapse camera to record the appearance of the children every 8 minutes. The time and temperature were recorded on each photograph as well. In general, he found a close relationship between room temperatures and the clothing worn by the children.

### Skin Temperature Measurements (Olesen and Fanger)

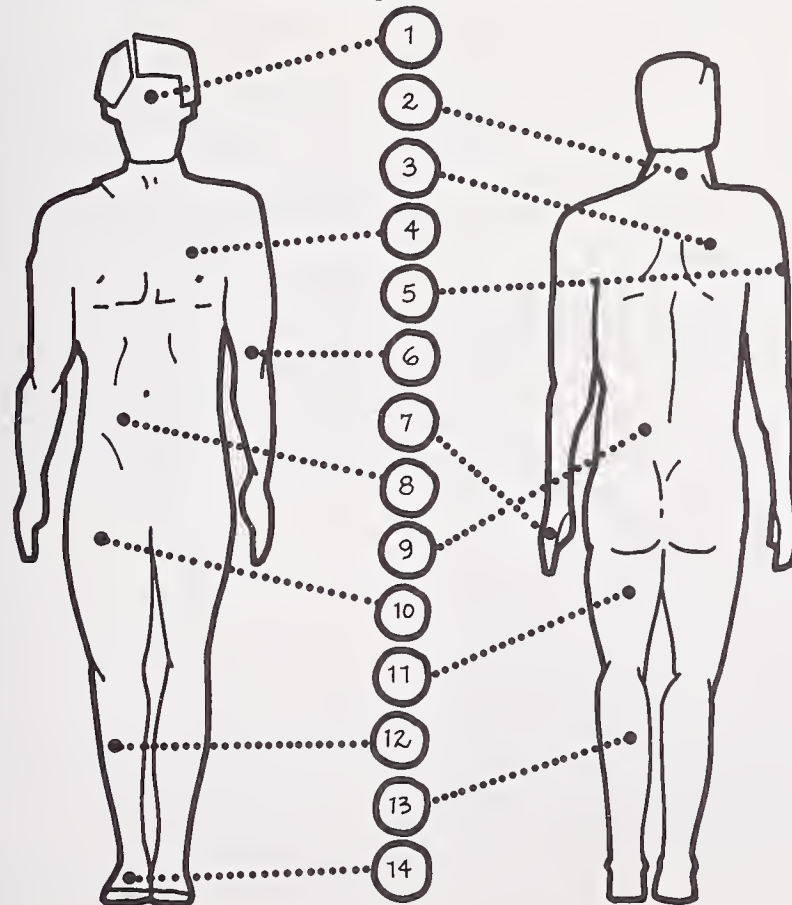

Another study dealing with the effects of thermal conditions on the behavior of school children was performed by I. Holmberg and Wyon. The investigation took part in an observational classroom, fitted with one-way mirrors to permit the children to be seen, without disrupting their activities. Four researchers, using identical checklists, observed 50 individual children, aged 9 to 11, in a predetermined sequence whereby each child was observed for 1 minute in every 10-minute period. The behaviors recorded dealt with posture, clothing, appearance, concentration, restlessness, and conduct. These categories of observation were developed in a preliminary pilot study. Three room temperatures (20 °C, 27 °C, 30 °C) were used to determine whether they affected the behavior of the children in an orderly way. The test sessions consisted of two 40-minute periods, separated by a 10-minute rest period.

We have discussed several procedures used to determine how thermal conditions may influence people. The earliest studies concentrated on physiological effects (e.g., skin temperature, sweat rate) and voting or rating procedures. Then, as we have seen, observational approaches were employed, based on the judgments of trained researchers. In all of these approaches we still must determine the implications of the observations and measurements made. Can thermal conditions be related to the ability of people to perform desired and/or needed activities?

### Checklist of Observations (Wyon and Holmberg)

1	Posture (-3 to +5)	Legs	apart	+1
			together	-1
		Arms	spread	+1
			held close	-1
		Hand	open	+1
		closed	-1	
		Leaning	back	+1
			head in hand	+1
2	Clothing (0 to +5)	Collar	open	+1
		Jacket	open	+1
		Arms bare		+1
		Shoes off		+1
		Removal of item		+1
3	Appearance (0 to +6)	Sweating		+1
		Flushed		+1
		Mouth open		+1
		Fanning face		+1
		Wiping forehead or hands		+1
		Loosening clothing		+1

#### Index of perceptible response to heat (1 + 2 + 3) (-3 to +16)

4	Inattention (0 to +4)	Gazing around		+1
		Closing eyes		+1
		Playing		+1
		Yawning		+1
5	Restlessness (0 to +3)	Writhing about		+1
		Tipping chair		+1
		Fidgeting		+1
6	Disturbance (0 to +4)	Laughing aloud		+1
		Talking to neighbor		+1
		Standing up		+1
		Teasing neighbor		+1

#### Index of undesirable classroom behaviour (4 + 5 + 6) (0 to +11)

### Field Studies

As far back as the 1920's, there was a realization among ASHRAE researchers that laboratory studies using college students were insufficient to define thermal conditions in buildings. Consequently, several field investigations were performed in office buildings. The subjects were male and female employees between 20 and 70 years of age. One such study was performed by A. Newton et al. in an air conditioned building in Minneapolis, Minnesota between May and July 1937. A questionnaire was given to the employees, to determine their responses to the environment. The questionnaires were filled out every day and collected the next day.

The building was divided into zones and wet- and dry-bulb temperatures as well as relative humidity measurements were recorded in the morning, at midday, and at the end of the working day. The measures of thermal environmental conditions were then compared with the response data. The study did not demonstrate simple clearcut relationships between environmental attributes and the responses of subjects.



Another field investigation was performed in an office building by L. Anderson et al. In the study, humidity conditions were systematically modified, while temperatures were not altered. The conditions were as follows: (1) humidifier working always; (2) humidifier operating 1 hour in the morning and 1 hour in the afternoon; (3) humidifier working 2 hours AM, 2 hours PM; and (4) humidifier not working. Wet- and dry-bulb temperatures were taken and workers (600+) were asked to fill out rating scales. Low humidity was cause for complaint, but temperature was a more critical factor when it exceeded 20-22 °C, the recommended range in Sweden.

### Thermal Comfort Scales (Anderson, et al.)

Condition	Judgment
<b>Temperature</b>	Much too hot
	Too hot
	Comfortably warm
	Neither warm, cool
	Comfortably cool
	Too cold
<b>Humidity</b>	Too dry
	Pleasant
	Too humid
<b>Air Quality</b>	Stuffy
	Normal
	Fresh
<b>Air Movement</b>	Too draughty
	Pleasant
	Still, stagnant

### Asymmetrical Heating

The architect's involvement with thermal comfort is often indirect, since in most modern buildings this area is addressed by thermal engineers. The major exception concerns radiant heating primarily related to window areas and/or lighting systems. The relationship of building design features (e.g., room dimensions, window sizes, placement and orientation, shading, materials, etc.) to thermal comfort was explored by F. Langdon and A. Loudon in a study of school buildings.

The school investigation was a follow-up of an earlier study dealing with office buildings. A questionnaire distributed to teachers dealt with questions about the use of the room, incidence of direct sunlight, and the efficiency of windows and blinds for ventilation and cooling. Thermal comfort was assessed on a 7-point scale ranging from comfortably cool to uncomfortably hot and by a question dealing with the frequency and intensity of discomfort. Teachers were also asked for observations about children (e.g., appearance) and opinions regarding the effects of overheating on their own performance and that of the children. Estimates of the thermal performance of the buildings (based on the building features cited above) were correlated with the thermal responses of occupants. The survey indicated the main factors which govern overheating in the summer, and (established) a general relationship between rise in calculated peak temperatures and increase in thermal discomfort.<sup>5</sup>

### Questions for Evaluating Subjects Responses to Asymmetric Radiation (Olesen, et al.)

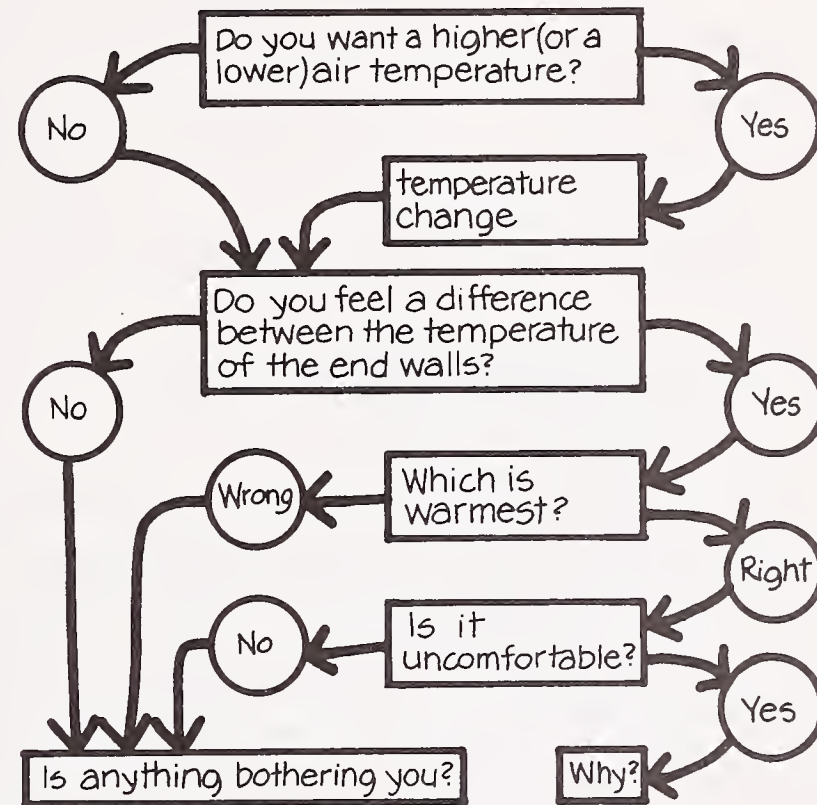

The problem of asymmetrical heating has also received considerable laboratory research attention in the past decade. For example, D. McIntyre (British physicist) conducted a series of experiments in a thermal environmental chamber where air was admitted through a permeable floor and was extracted through grills set at

the top of the walls. Four subjects were run at one time. They sat in the chamber for 45 minutes, reading, talking, writing, or engaging in other sedentary activities and then rated the environment by means of a variety of rating scales. The results showed that uneven radiation was disliked by subjects.

<sup>5</sup> F. J. Langdon and A. Loudon, "Discomfort in Schools from Overheating in Summer," *Journal of The Institution of Heating and Ventilation Engineers*, 37 (March 1970).

The same author examined five levels of relative humidity (20% to 60%) with temperature held constant at 23 °C for 5 hours. In this investigation, McIntyre used a questionnaire and a mood adjective checklist to obtain responses from subjects to the environment. Prior to the study a personality test was administered to measure introversion and extroversion characteristics of the subjects. The differences in relative humidity had no apparent effect on the subjects.

Unlike other M/E problem areas (e.g., visual perception) where the features of the physical environment are sometimes not given sufficient attention (to correlate with human responses), thermal comfort research has always stressed this requirement. On the other hand, thermal comfort work needs to: (1) cover extended time periods, (2) deal with the responses of individuals (rather than group averages), and (3) be conducted under realistic field conditions. (The latter criticism applies to most M/E research.)

Diagram of Test Chamber (McIntyre)

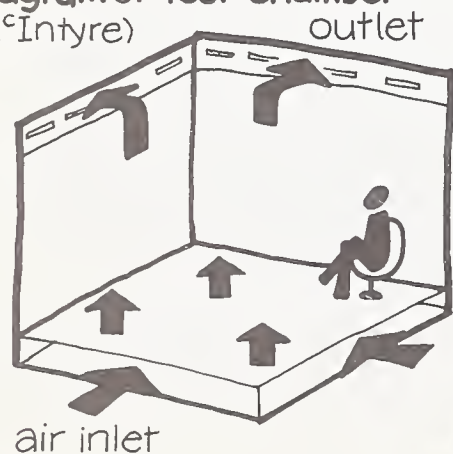

## Thermal Comfort Mood Adjective Check List

(McIntyre)

Time \_\_\_\_\_ Name \_\_\_\_\_

Each of the words in the following list describes feelings or mood. Please use the list to describe your feelings at this moment. Mark each word according to these instructions:

If the word definitely describes how you feel at the moment you read it, circle the double star (★★) to the right of the word. For example, if the word is *calm* and you are definitely feeling calm at the moment, circle the double star as follows:

Calm (★★) ★ ? no (This means you definitely feel calm at this moment).

If the word only slightly applies to your feelings at the moment, circle the single star as follows:

Calm ★★ (★) ? no (This means you feel slightly calm at the moment).

If the word is not clear to you or if you cannot decide whether or not it describes your feelings, circle the question mark as follows:

Calm ★★ ★ (?) no (This means you cannot decide whether you are calm or not).

If you clearly decide that the word does not apply to your feelings at this moment, circle the no as follows:

Calm ★★ ★ ? (no) (This means you are sure you are not calm at this moment).

Work rapidly. Your first reaction is the best. Work down the first column before going to the next. This should take only a few minutes.

worthless	★★ ★ ? no	sad	★★ ★ ? no	empty	★★ ★ ? no
angry	★★ ★ ? no	earnest	★★ ★ ? no	tired	★★ ★ ? no
concentrating	★★ ★ ? no	sluggish	★★ ★ ? no	kindly	★★ ★ ? no
drowsy	★★ ★ ? no	forgiving	★★ ★ ? no	fearful	★★ ★ ? no
affectionate	★★ ★ ? no	clutched up	★★ ★ ? no	regretful	★★ ★ ? no
apprehensive	★★ ★ ? no	lonely	★★ ★ ? no	egotistic	★★ ★ ? no
blue	★★ ★ ? no	cocky	★★ ★ ? no	overjoyed	★★ ★ ? no
boastful	★★ ★ ? no	lighthearted	★★ ★ ? no	vigorous	★★ ★ ? no
elated	★★ ★ ? no	energetic	★★ ★ ? no	witty	★★ ★ ? no
active	★★ ★ ? no	playful	★★ ★ ? no	rebellious	★★ ★ ? no
nonchalant	★★ ★ ? no	suspicious	★★ ★ ? no	serious	★★ ★ ? no
sceptical	★★ ★ ? no	startled	★★ ★ ? no	warmhearted	★★ ★ ? no
shocked	★★ ★ ? no	defiant	★★ ★ ? no	insecure	★★ ★ ? no
bold	★★ ★ ? no	thoughtful	★★ ★ ? no	self-centered	★★ ★ ? no
helpless	★★ ★ ? no	hopeless	★★ ★ ? no	pleased	★★ ★ ? no
miserable	★★ ★ ? no	tense	★★ ★ ? no	vulnerable	★★ ★ ? no

Have you marked all the words?



A study designed to overcome some of these deficiencies was performed by Humphreys and J. Nicol. It took place at the then Building Research Station of the United Kingdom in a building housing offices and laboratories between April 1967 and July 1968. The subjects were 18 members of the scientific and clerical staff who worked at their regular jobs while participating in the study. On the desk of each subject was an automatic environmental monitor which recorded globe temperature, air velocity, wet-bulb and dry-bulb temperature, and comfort votes. The monitors were connected to a central data logger. At hourly intervals an auditory signal (whistle) indicated when it was time to register a vote. Comparisons of simple measures of globe and air temperature were also good as complex indices for the conditions studied.

## Conclusion

There has been a dramatic shift in emphasis in recent years among the researchers investigating thermal comfort. Instead of relying primarily on physical and physiological measurements made in laboratories, "real world" studies are on the rise. Humphreys, Fanger, Wyon, and A. Nevins (psychologist), among the most active researchers in this discipline, are all using psychological and performance related measures to a greater extent than they have in the past. Fanger indicates that long-term performance oriented investigations, lasting several weeks, are being initiated in Denmark. This approach more nearly simulates the actual experience of building occupants than studies of short duration.

It is time to examine a number of assumptions which form the basis of our present definition of thermal comfort. It is often taken for granted that uniform environmental conditions are best. Heating and cooling systems are designed to produce uniform and stable temperatures, but where is the information to demonstrate that this is a desirable goal? Rooms have temperature gradients, vertically and horizontally, and evidence exists that people are often sensitive to such differences; but while extreme differences are cause for complaint, small ones might be desirable.

## Thermal Comfort Research Applicability

Variables	Real Life Conditions	Experimental Studies
Setting	Complex environment	Sterile laboratory
Activity	Meaningful, complex	Simple, artificial
Thermal Conditions Experienced	Dynamic, changeable	Static
Population	Young—Aged Healthy—Handicapped	Young healthy adults
Duration	Relatively short (several hours at most)	Long term (weeks, months)

Fanger and I. Griffiths (British physicist) summarized requirements for better information dealing with the thermal environment.

*Research has concentrated on investigation of subjective warmth as a function of the four major physical variables, but work has (only) begun on other physical variables such as non-uniformity (with respect to space and time). The general picture that has emerged is that the work of the psychologist in this field has just begun.<sup>6</sup>*

Finally, design for an energy efficient and acceptable thermal environment should include a degree of flexibility to enable occupants (or building operators) to control environmental conditions, e.g., by opening windows, having "local" thermostats, etc.

<sup>6</sup> Fanger





*Deterioration of Air Quality (EPA Documerica)*



# 15

## The Olfactory Environment— Air Quality

- Characteristics of Odors
- Human Olfactory Response
- Odor Quality
- Research Procedures
  - Selection of Subjects
  - Laboratory Procedures
  - Field Techniques
  - Measurement Approaches
- Conclusion

The FERS Odor Square (part of Henning's smell prism)

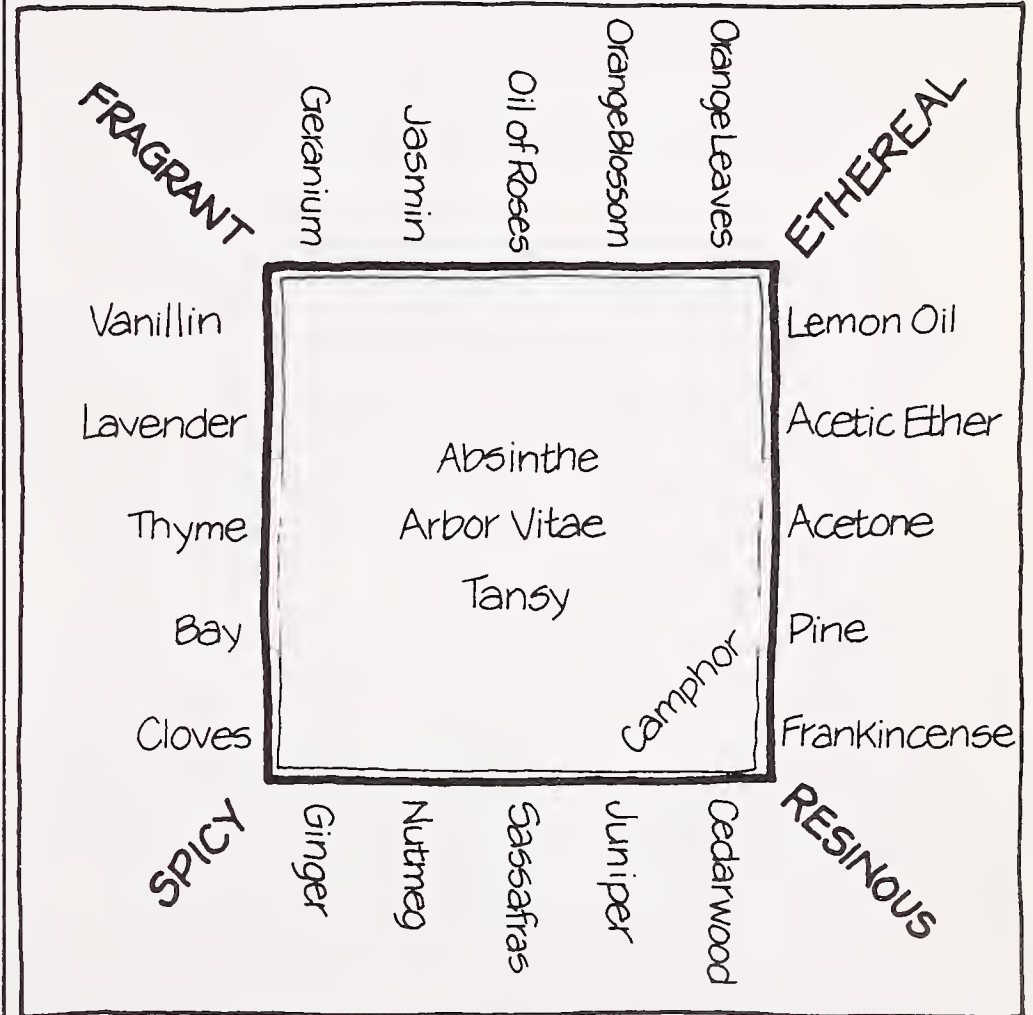

Activities are sometimes identified by means of characteristic odors. This attribute is both a source of enjoyment and a cause for complaint. For example, many people retain a fond memory of the aromas of bread baking and coffee roasting. We are all aware of perfumes, soaps, and candles developed primarily to satisfy our desires for pleasant odors. Similarly, the food industry has been at the forefront of using odors to enhance the appeal of their products especially foods derived from chemicals.

On the other hand, many environmental odors are undesired by-products of technology. Manufacturing processes and transportation systems both contribute to air quality problems in our outdoor environment—thereby creating problems in buildings as well.

When dealing with air quality, we should recognize that although the nose is a sensitive detector, it is not an infallible one with respect to safety. Many gases which are dangerous to health are odorless (e.g., carbon monoxide).

The architectural literature sometimes deals with odors encountered in certain building types—hospitals, museums, libraries, schools, and homes. Although agreement exists that many such buildings have distinctive odors, these opinions are not substantiated by research which is sparse in this area. Several researchers have examined odors from the standpoint of environmental pollution problems, and these will be discussed.

When compared with the research techniques available to investigators of the auditory and visual environment, the state-of-the-art in odor investigations is best described as primitive. This study area has been largely neglected by many disciplines which would logically be expected to pursue this work—namely physiologists and experimental psychologists. Those few researchers who have been active have had only limited success. The primary reason for this rather bleak picture is that the study of odor poses a unique set of problems for the researcher.

Odors appear to have strong emotional impacts on people which are difficult to identify and measure. Many thousands of different odors can be discriminated, and different concentrations can also be perceived. People vary considerably in their ability to make reliable odor judgments.

Olfaction is frequently described as an alarm system because of its extraordinary sensitivity and the ability of people to distinguish among thousands of different odors. People can detect such minute concentrations of odor producing substances that chemists cannot accurately measure the concentrations.

Another major problem with odor research is the availability of experimental apparatus and techniques to conduct studies. Unlike auditory and visual studies, where sophisticated instrumentation is the rule, the working tools available to the odor researcher permit only rather crude measurements.

Uncertainties exist in all phases of study—from defining the characteristics of an odorant through the measurement system used to vary and transport it to the subject, and the means by which a person receives and interprets the odor. Added to these problems is the need to develop a classification and descriptive system whereby odors can be reliably and accurately described. Such a system is needed to form the basis for effective communication among scientists and laymen. The design of experiments in olfaction must be especially sensitive to adaptation or olfactory fatigue, which can lead to faulty findings if ignored. This phenomenon is well known to anyone who has encountered a strong odor, which after a time is almost unnoticeable.

As a result of the complexity of designing appropriate investigations, methodological studies are of particular importance. Finally, since the subject of odors is not frequently covered in architectural publications, we will provide a brief background to assist in the understanding of the research methodologies described later.

## Characteristics of Odors

Odors, like other sensory stimuli, can be placed into one of two general categories: source and ambient. Source odors are those existing at the point of origin or at their point of exit to the general atmosphere, and ambient odors are those existing in the general atmosphere. Odor sources can be categorized as confined or unconfined. Confined sources can generally be characterized in terms of volumetric rate of discharge, temperature, moisture content, location, elevation, and area. Typical confined sources include stacks and fume vents. Unconfined sources consist of large sources such as sewage treatment plants and stockyards where the extent of the source precludes its confinement.

Odors can be characterized by intensity, quality, acceptability, and pervasiveness. Odor intensity is defined as the numerical or verbal indication of the strength of an odor. Odor quality is the verbal description of an odor, accomplished within the vocabulary capabilities of the individual and normally expressed by comparison with common odors. Acceptability is an absolute acceptance/rejection of the odor on the basis of intensity and/or quality. Pervasiveness is the ability of an odor to spread throughout a large volume of air and persist at perceptible levels.



The human nose is the ultimate standard against which the intensity of an odor must be evaluated. The response of the human nose to odors is bounded at the lower end by a threshold value and is marked near the upper end by a concentration provoking a sense of objectionability. The threshold is defined as the concentration at which odor quality can be just recognized. The detection threshold limit is used most commonly by researchers, although the quality-recognition-sensation has resulted in more consistent research findings than the detection sensation.

Individual response for detection of odors varies widely. As a result, a panel of people is normally used to determine odor threshold concentration and to report threshold values as the "effective dosage" at which 50% of the panelists perceive the odor. Reported threshold concentrations for the same odorant vary widely, not only because of individual response variability, but also because of lack of standardization of techniques for managing samples and presenting them to observers.

### Henning Prism

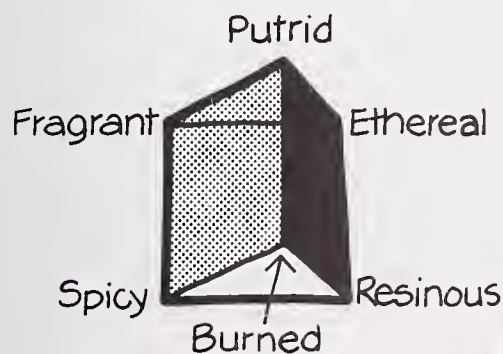

### Human Olfactory Response

Human odor intensity scales are designed to measure the perceived intensity of some specified characteristic of a material. The descriptor of the odor may be general (e.g., overall intensity of odor) or specific (e.g., pungency). Trained subjects, specifically instructed in the attribute to be evaluated, are presented a series of samples. Each sample is rated by intensity with alternative points anchored as follows: none, slight, moderate, large or strong, and extreme.

Olfactory sensitivity is known to be highly variable and is subject to physical as well as psychological influences. Some of the factors which have been reported to influence the olfactory sensitivity are as follows:

- Odor sensitivity of the individual observer varies diurnally (according to the time of day) but is reasonably constant for a group of observers.
- The sense of smell is rapidly fatigued, though fatigue for one odor does not necessarily affect the perception of dissimilar odors.
- Responses to odors are not totally objective because psychological responses vary in different observers.
- The sensitivity of observers varies widely in that some persons are extremely sensitive while others are almost insensitive to odors; sensitivity decreases with age.

### Odor Classification Schemes

Henning Name	Examples	Horstman Name
Spicy	Cloves, cinnamon, nutmeg	Flowers
Flowery	Heliotrope, jasmine	Pulp mill
Fruity	Apple, orange oil, vinegar	Smoke, woodsmoke
Resinous	Coniferous oils, turpentine	Burning leaves
Foul	Hydrogen sulfide; products decaying	Mustiness
Burnt	Tarry and scorched substances	Gasoline

### Odor Quality

The characteristic of odor quality is normally defined in terms of commonly perceived odors or by associating unfamiliar with familiar odors. Experimental subjects do not have the vocabulary to describe the thousands of odors which can be distinguished by most people. To make this problem still more complex, often the quality of an odor changes with dilution.

### Research Procedures

Unlike noise research where dBA meters approximate many auditory responses and are easily read, in odor research no comparable "hardware" capability exists. Instead people are relied upon as an integral part of the "measurement system," both to sense the odor, and to measure it. Consequently, differences among individuals are a major source of error in research, and methods have been devised to minimize these errors. One technique designed for this purpose is to carefully train subjects, thereby obtaining consistent data from experts.

## Selection of Subjects

Prior to training, the researchers can eliminate potential subjects by using a screening test to ensure that a minimum level of performance is achieved. J. Wittes and A. Turk (chemist) devised the **triangle test** to select people for participation in an odor study. Three odorous solution samples were presented to subjects, two of which were the same. The task of the person was to correctly identify the "odd" odor. A series of such trials was conducted and the scores calculated. Participants in the study were selected on the basis of achieving the highest total scores.

In a follow-up study, Turk with S. Mehlman developed an alternative procedure to the triangle test to select experimental participants. The subjects were first exposed to a group of odors to be judged. They then were asked to define the odors in terms of from three to eight qualities that seemed reasonable in light of subjective associations and chemical analysis. Selections were then made on the basis of familiarity with the odors and the results of the analytical findings, i.e., ability to consistently identify odors. Then an odor *standard* was made up to represent each quality description that had been identified. These standards were then used (at various levels of concentration) as a basis of comparison for the odors being investigated.

## Laboratory Procedures

Odor researchers have relied heavily upon measures of absolute thresholds in their studies (the minimum concentration of an odor which can be detected). By mixing sufficient uncontaminated air with a measured quality of odorous air, the odor present in the mixture can be reduced to threshold levels. This technique is usually termed the **vapor dilution method**.

The first person to use the technique was Zwaardemaker (Dutch psychologist) who invented the **olfactometer** in 1895. This instrument is the prototype of those in general use today. In its simplest form, it consists of a glass tube open at both ends, over which is slipped a hard rubber or plastic tube. The inner surface of the tube is impregnated with the odorous material being investigated. As the tubes are extended, more of the air inhaled comes in contact with the odorous material, the odor concentration thereby being raised. By placing markings on the tubes, the amount of exposed surface of the odorant can be measured at the time that a subject indicates that it is barely detectable—thereby providing a physical measure which correlates with the judgment. This procedure, being quite cumbersome because of the nature and size of the experimental apparatus, is confined to laboratory investigations of "synthetic" chemical odors, as contrasted to environmental ones. The olfactometer limited the experimental control of the stimulus, i.e., there was no assurance that the same amount of

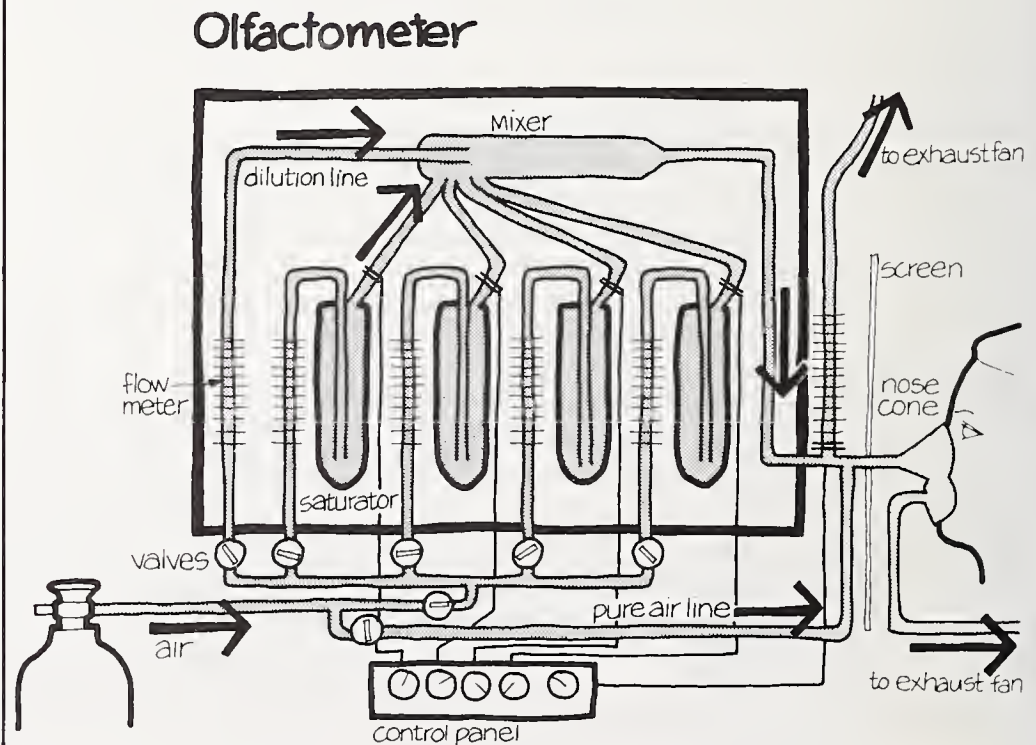
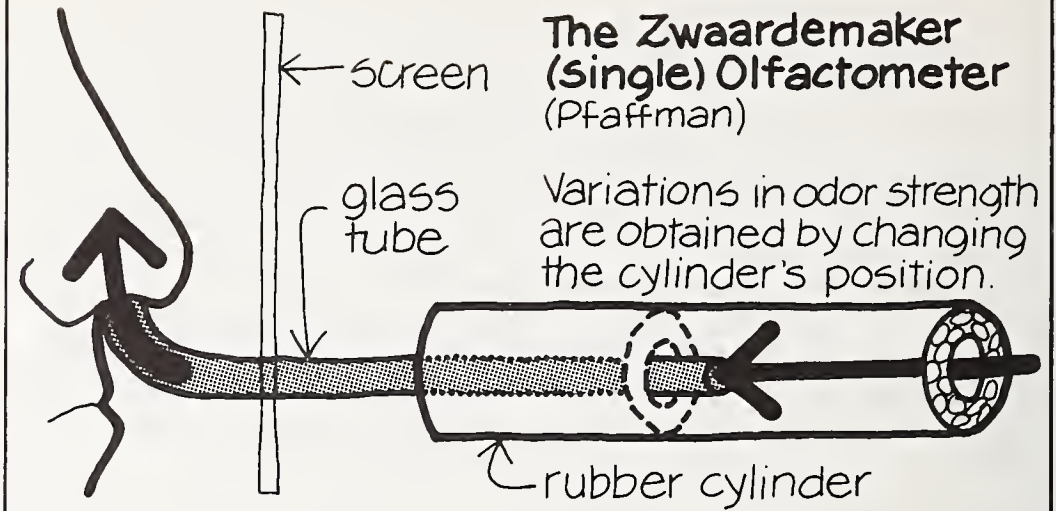



odorous material was presented on two successive exposures.

C. Elsberg and I. Levy developed an alternative procedure to overcome this difficulty. The method entailed the use of an odorous liquid which was placed in a 500-cc bottle. An outlet tube leads to the nostrils; an inlet tube is attached to a syringe. Air is forced into the bottle using the syringe as a pump. With the nosepiece in place, the stopcock on the inlet tube is removed, releasing a "blast" of odorous vapor into the nostrils. In successive trials, the air pressure is modified systematically, to determine the threshold. This approach, while solving one problem, created another one—pressure variations can be sensed by subjects, thereby confusing experimental findings.

### Blast Injection Method

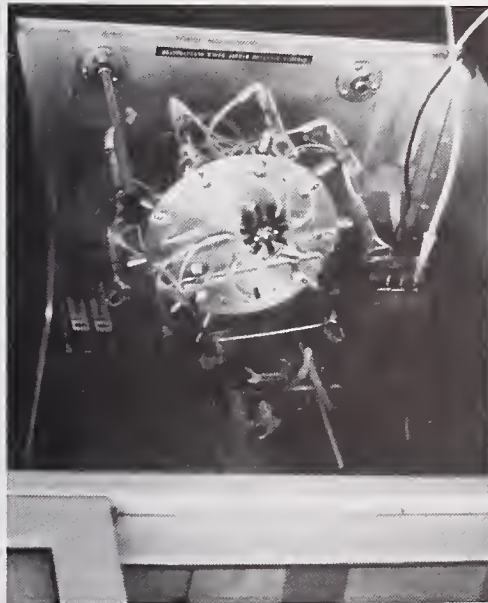
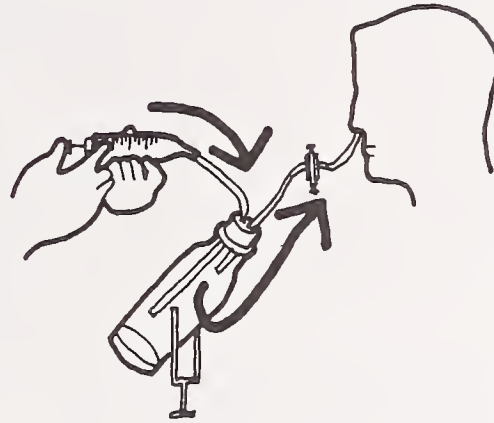

Odor Study Apparatus  
(John Pierce Foundation)



Subject Participating in Odor Study  
(John Pierce Foundation)

### Field Techniques

The Copley International Corporation conducted a national study on air pollution for the Environmental Protection Agency incorporating both laboratory and field procedures. The investigation was conducted in four phases. The first was directed toward screening subjects who were to take part in the study, using the triangle test. Then, training sessions were conducted with panel members, using odor reference standards. Four field investigations were performed near refineries and a rendering plant. The study consisted of placing panelists around a location. Subjects were instructed to record odorant intensities at 30-second intervals for 20- to 30-minute periods. The intensities were rated on the basis of a 4-point dilution scale, practiced in the laboratory. They relied on their memories to compare odors with the standards. Finally, the subjects returned to the laboratory to be tested again as a cross-check against the initial triangle test.

In the field investigation a device called a **scentometer** was employed as a measurement instrument. The scentometer is a commercial tool for measuring odor intensities at the particular site where there is an odor problem. It was designed for use by air pollution control inspectors. It is small (5 in. x 6 in. x 2 1/2 in.) (13 cm x 15 cm x 6 cm) and functions by diluting air samples with purified air, just as the other instruments, but dilutions are accomplished in a different way. A combination of critically sized holes admits ambient air to the "mixing chamber" which then passes through two nosepieces to the lungs of the subject as he breathes. Under normal conditions, the subject breathes air through a scentometer for a minute with all odorous inlets closed. Then, the odor is presented to the subject in a series of trials in increasing concentrations. That is, the smallest opening is used first, then the next largest, and so on.

### Odor Test

(Copley International Corporation)



Pleasant • Neutral • Unpleasant • Very Unpleas. • Unbearable



One of the most pervasive unwanted odors in the community is that of engine exhausts. Consequently, a number of investigations have addressed this problem. Colucci and Barnes conducted odor tests on a diesel bus using an aircraft hangar to produce a controlled environment. Different degrees of exhaust dilution were achieved by varying the distance between the bus and a panel of six subjects. The experimental task was to judge whether the diesel exhaust odor could be detected over the background odors. The thresholds were then defined in terms of distance; the greater the distance, the greater the odor intensity.

Turk has developed a kit of diesel odor quality and intensity standards for the U.S. Public Health Service. The kit is taken to a site, and experimental participants are asked to judge which of the four qualities are present: diesel composite (D), burnt-smoky (B), oily (O), or aromatic (A). When a quality is determined to be present, a set of concentrations of the quality (e.g., diesel composite—D, 1 through 12 with 12 being the strongest) is given to the person who then matches the perceived environmental odor with the standard.

A comprehensive study of diesel engine exhaust odor was also performed by K. Springer and C. Hare. They employed both questionnaire surveys and a mobile odor evaluation laboratory in a study conducted in five major cities. Two diesel engine exhausts were used to produce the odors used in the study which was conducted under carefully controlled conditions. The study was conducted in the mobile laboratory ("sniff-mobile"), using the procedure developed by Turk. In addition to participating in the preceding phase of the study, subjects were asked to rate odors on a 5-point scale.

### Measurement Approaches

Rating scales have been a preferred method of evaluating odors. Another approach has been to have subjects sample odors and then try to describe what they smell like. This method is seldom used because the findings are very diverse, and therefore difficult to analyze and interpret.

One method employed to combine the features of verbal descriptors and scaling (multidimensional scaling) was developed by H. Moskowitz and C. Gerbers. They used 15 chemicals as odorants, and rated them in a number of ways. Subjects were first asked to rate the intensity of each odor by a numerical rating. (Odors receiving the same rating were considered to be equally strong.) The subjects then rated each odor in terms of a number of attributes. Zero

was to be used when the attribute was not noticed, but no upper limit was given for ratings. Next, the subjects rated the pleasantness (+) or unpleasantness (-) of each odor, with (0) being neutral. The final task was to judge the dissimilarity of: (1) pairs of odorants, (2) odorants and word descriptors, and (3) pairs of word descriptors using the same procedure employed to rate the 17 attributes. The results were analyzed and interpreted using multidimensional procedures.

### Descriptions of Odors (Moskowitz and Gerbers)

1. Sweet
2. Pungent
3. Heavy
4. Flowery
5. Solvent
6. Fragrant
7. Oily
8. Minty
9. Burnt
10. Goaty
11. Putrid
12. Camphor
13. Fruity
14. Spicy
15. Intensity
16. Pleasantness
17. Familiarity

### Conclusion

The ability of a building occupant to judge the quality of air is likely to become more important as energy conservation programs are formulated. A number of the techniques suggested to save energy in buildings has important implications for the quality of the air in buildings. For example, if buildings are sealed better than they have been, there will be a lower rate of air exchange between the indoor and outdoor environments. This may or may not improve the air indoors depending on the relative quality of indoor and outdoor air. Another suggested energy saver is to reduce the ventilation requirements now typically employed in buildings. Reduced ventilation, if combined with tighter buildings, will further reduce the indoor-outdoor air exchanges. This would maximize the influence of any indoor activities on air quality and possibly lead to undesirable odors and unhealthy conditions. The tradeoffs between energy conservation and air quality deserve serious attention by architects, mechanical engineers, and planners. Therefore, a need exists for improved methods and information dealing with the quality of outdoor and indoor air.



# 16

## Environmental Stability— Movements

Simulation Studies—Building Movement  
Field Studies of Building Movement  
Studies of Movement—Transportation  
Performance Studies  
Conclusion

Movement in buildings typically results from wind, construction activities, mechanical devices, neighboring factories, and transportation systems—roadway, rail, and aircraft. Movement also occurs as a result of activities by building occupants, e.g., children's games. Until quite recently, architects have not demonstrated great concern about building deflections as a source of occupant dissatisfaction. The materials and techniques commonly used produced structures with few building movement problems. Newly developed methods, employing "lightweight" construction techniques, however, have altered the situation. While the engineers and designers have become highly sophisticated in producing buildings which are safe from a structural standpoint, the acceptability of buildings has assumed greater prominence, that is, the success of the structure in meeting the day-to-day needs of the occupants. Unfortunately, the latter day construction methods have introduced unwanted deflection. For example, floor deflections when walking across a room might be annoying in themselves but might also raise questions in the minds of occupants concerning the quality and safety of construction, regardless of the objective facts. High-rise structures have been prone to drift problems during storms and high winds. Vibrations have been another source of difficulty, sometimes associated with mechanical equipment, in other instances as a result of human related activities.

Since building movement has only recently been recognized as a problem area, most researchers dealing with the topic have been concerned with movements produced by vehicles, primarily to better understand the effects of vibration on people. While a few of these studies are mentioned, the reader should be aware that the experimental variables (usually vibrations) employed in them differ considerably from those encountered in buildings. As in many sensory research areas, an early study has made a profound impact upon later research.

The first of the more thorough research programs was carried out by H. Reiher and F. Meister. A total of 25 persons, between 25 and 40 years of age, either stood or lay down on a platform undergoing vertical or horizontal motion. After being exposed to one type of vibration for about 10 minutes, subjects were asked to make judgments on a 6-point scale (imperceptible, just perceptible, distinctly perceptible, strongly perceptible, unpleasant, or exceedingly unpleasant). The curves derived by these authors are in widespread use today and serve as the foundation for all following studies.



## Simulation Studies— Building Movement

P. Chen and C. Robertson reviewed studies of movement in buildings and performed a series of investigations using a motion simulator. They indicated that human reactions to vibration can be classified into six comfort zones. While describing their own investigations they further note that absolute thresholds (barely detectable) vary considerably from person to person and are influenced by several factors.

Chen and Robertson employed a motion simulator (HATS) consisting of a room mounted on a platform which could be moved simultaneously in two directions. The room had a door but no window (which might provide visual motion cues). Of particular interest are the instructions given to the subjects. This factor is an important one often neglected in research studies, and yet has an important influence on the results of behavioral studies. The same researchers systematically varied the information given to the subjects. The subjects in one instance were not told to expect the room to move. Instead, they were told that the study was a visual screening test, and later, tests of distance and height judgments. In a follow-on test, subjects were told the nature of the study, i.e., to determine when motion was perceived.

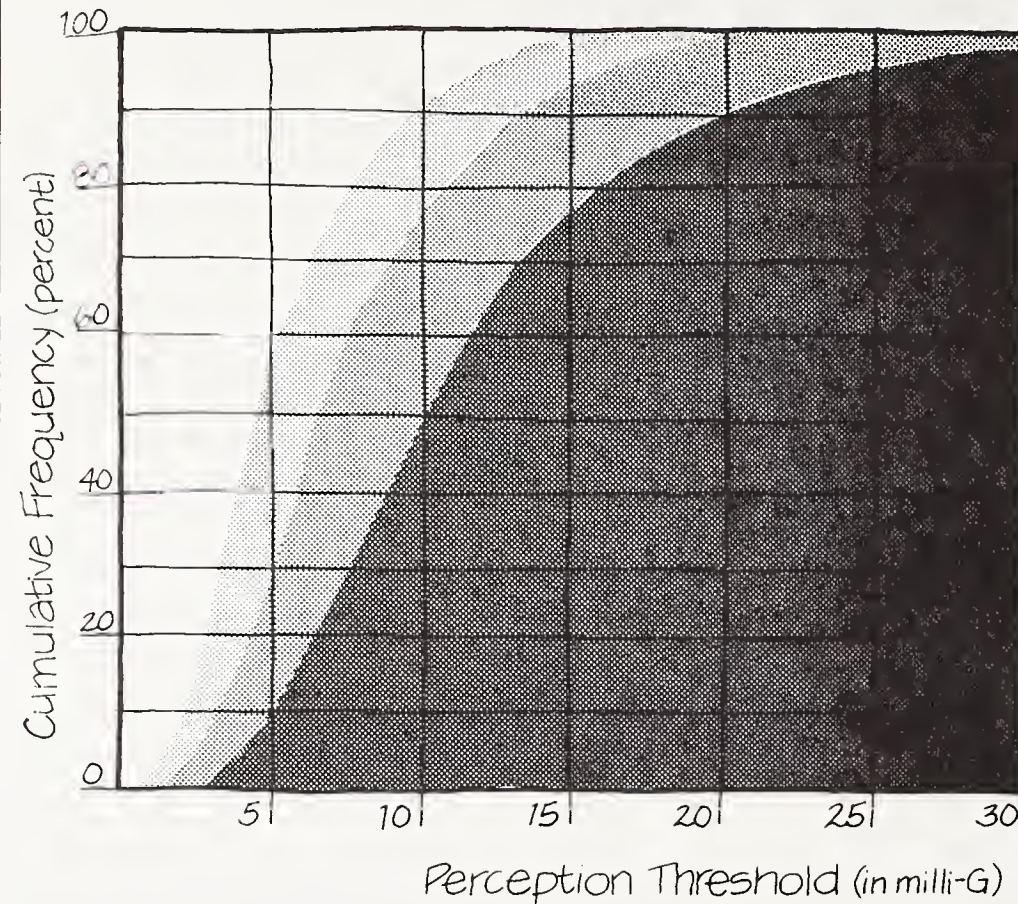
## Dynamic Response Recurrence Diagram of Building Movement (Chen, Robertson)



-  standing (fore & aft)
-  sitting (side to side)
-  sitting (fore & aft)

M. Yamada (engineer) and T. Goto (engineer) designed a simulated house which enabled them to systematically vary a number of parameters associated with the perception of motion in buildings. The purpose of their experimental program was to develop criteria for motions in tall buildings. The researchers employed a variety of approaches in their work. The first procedure consisted of asking subjects to stand *in the same direction to the longitudinal axis for fore and aft test*. When these tests were completed "side to side tests" followed. The simulator was operated in terms of a predetermined schedule. The experimental subjects indicated *whenever the sensation of motion changes*. This information was recorded together with a description of the characteristics and duration of the motion in physical terms.

## Factors Influencing Vibration Thresholds

- Period of Isolation
- Body Orientation
- Body Movement
- Body Posture
- Expectancy of Sway
- Visual Cues
- Activity being performed



## Motion Simulator (Yamada & Goto)

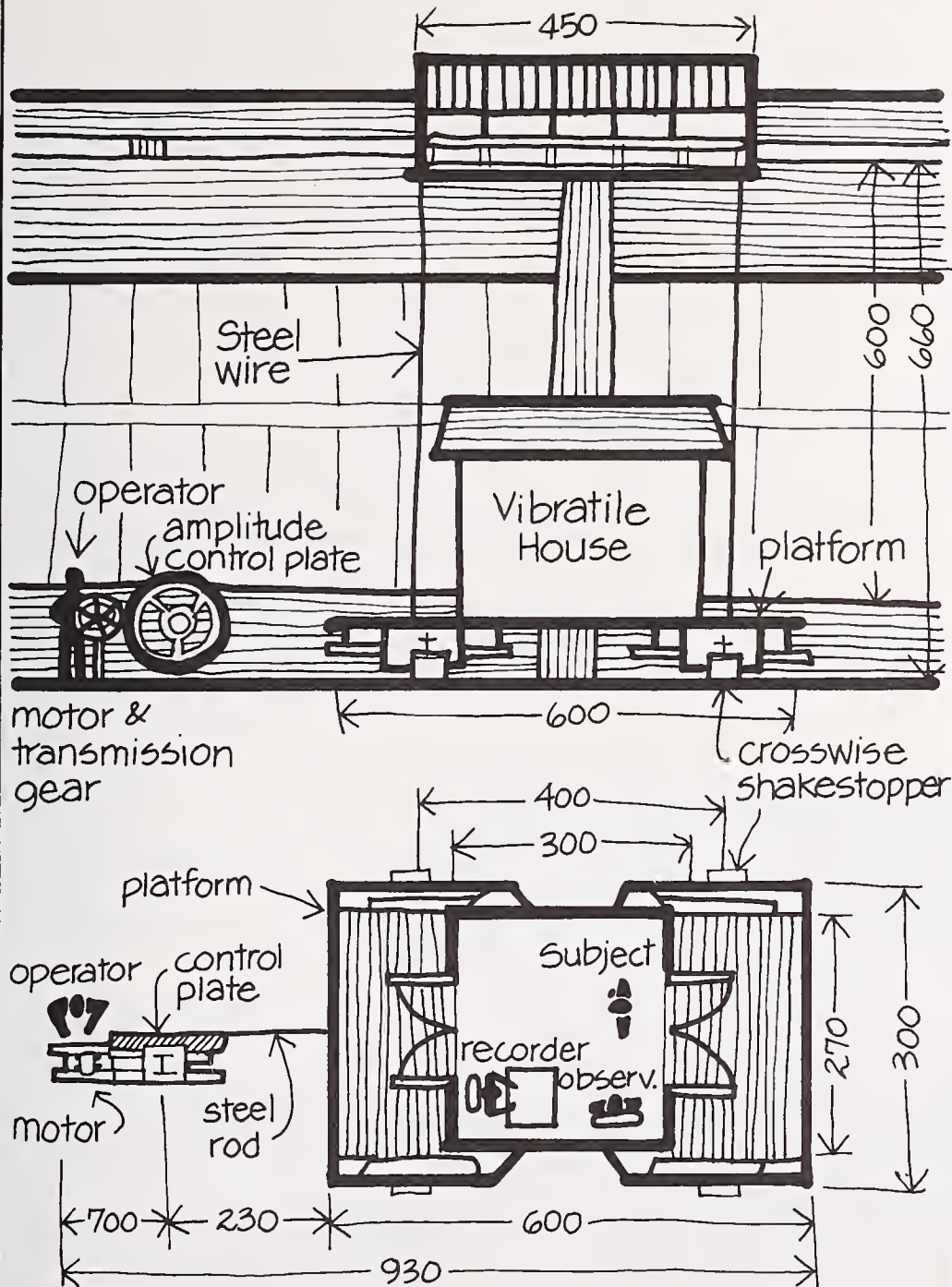

The next series of studies described by Yamada and Goto was designed to determine the effects of motion on task performance. The task of the subject was to trace lines, squares, and circles while seated in a chair within the simulated house. The responses measured were the time taken to complete the tasks and the deviations from the base line, i.e., the degree of accuracy of tracing. The experimental conditions were similar to those employed in the earlier studies.

The final study by the same authors was concerned with the movement of people in buildings—vertical and horizontal. In this investigation the researchers used a motion picture camera, focusing on the head and feet of the subjects. The camera was set on a platform above the house (the roof was removed). Vertical and horizontal lines spaced 200 mm apart were drawn on the ceiling and the walls of the house. The subject was brought into the house and marks were placed on the top of the head

## Experimental Factors for Human Perception and Tolerance Threshold (Yamada and Goto)

Sex	Male			Female
Age (years old)	8-12 Childhood	18-22 Youth	45-55 Middle age people	18-22 Youth
Number of Subjects	5	20	5	5
Body Posture	standing	sitting on a chair	standing	sitting on a chair
		sitting on the floor		sitting on the floor
		lying on the floor		lying on the floor
Body Orientation		fore and aft side to side		fore and aft side to side

and the toes. Then, with the house being moved in accordance with the experimental design, the subject "walks a line" back and forth between walls at a pace of 84 steps per minute (indicated by a metronome). The subject is photographed while the tests are performed. A similar study was performed with subjects ascending and descending a stairway.

These studies demonstrate a highly innovative method of collecting building user responses to movement under controlled, yet semi-realistic conditions.

**Field Studies of Building Movement**

Of the several causes of building movement, wind has perhaps the most widespread effect. J. Reed (engineer) investigated wind-induced motion in two office buildings. He instrumented two buildings to measure the motions induced during severe storms. After storms lasting almost 24 hours he conducted a survey of the building occupants to determine their reactions. He was especially interested in identifying the particular cues employed by occupants in making their assessments (auditory, visual).

The problem addressed above is often termed one of "instructional set." Research subjects are directed to attend to certain features of the environment while ignoring others. This procedure frequently makes it difficult for researchers to relate laboratory data to realistic settings.

D. Allen and J. Swallow (Canadian researchers) describe a study procedure recommended by them to determine whether a vibration problem exists in a building. It is based on a "heel impact" test, where a person standing on his toes drops suddenly to his heels. They suggest that the test be performed by a 170-lb. (77 kg) man, standing at the

geometric center of a floor. Subjective impressions would be obtained from a subject also standing near the center of the floor. The authors further state that: *The test should be repeated at the 1/4 and 1/6 points on the centerline perpendicular to the direction of the stiffeners.*<sup>1</sup>

**Noticeability of Motion Cues (MIT Survey)**

Motion Cues	Building A			Building B		
	Total % (if noticed)	Most noticeable	Next most noticeable	Total % (if noticed)	Most noticeable	Next most noticeable
Movement of doors, fixtures, etc.	56.2	18.8	9.4	64.1	9.4	37.7
Creaking sounds	92.1	28.1	34.4	64.1	20.8	26.4
Feeling self moving (includes motion sickness symptoms)	62.5	28.1	17.2	69.9	51.0	15.1
Looking out window and sensing building moving	62.5	4.7	10.9	11.3	1.9	3.8
Comments from co-workers	37.5	12.5	7.8	17.0	11.3	
Other	46.9	4.7	12.5	34.0		1.9
No preference		3.1	7.8		5.6	15.1
Not knowing building was moving				5.6		
<b>Total</b>		<b>100.0</b>	<b>100.0</b>		<b>100.0</b>	<b>100.0</b>

<sup>1</sup> D. L. Allen and J. L. Swallow, "Annoying Floor Vibrations—Diagnosis and Therapy," *Journal of Sound and Vibration* (1975).



At the Commonwealth Experimental Building Station, N.S.W., Australia, a vibrator was designed, built, and used. Research subjects performed their usual tasks unaware of the existence of the vibrator. The study consisted of enabling subjects to volunteer comments about their environment. The study authors noted that the lower values of the Reiher-Meister Scale did not elicit comments about vibration until the movements were brought to the attention of subjects, at which time the movements were noticed. They point out that the Reiher-Meister Scale was developed by subjecting people to vibration in a laboratory and asking them to state their reactions to movements. Under these circumstances, it is likely that subjects would be aware of vibrations that would not be noticed under everyday conditions.

### Studies of Movement— Transportation

W. Helberg and E. Sperling had subjects sit on a wooden bench which was attached to a vibrating table. The bench was moved either horizontally or vertically, but not both ways simultaneously. Vibrations that were "very nearly" sinusoidal, at frequencies of between 1 and 12 Hz, were used. The amplitudes employed were between 0.01 and 2.5 cm. Subjects were seated for periods ranging from 2 to 10 minutes. After this time, they were asked to make judgments on a 7-point scale (just perceptible to intolerable).

D. Parks and F. Snyder investigated human reaction to low frequency vibration. A hydraulically actuated shake table was used to provide vertical, sinusoidal vibrations at frequencies ranging from 1 to 23 Hz. The vibration platform was mounted with a standard aircraft seat having felt covered plywood in place of a seat cushion. Four categories of subjective judgments were recorded along with electrocardiograms. The subjects were asked to identify four levels of vibration severity: (1) Definitely perceptible, (2) Mildly annoying, (3) Extremely annoying, and (4) Alarming.

A study by A. Weisz et al. compared the effects of sinusoidal and random vibration. Actually three different vibration conditions were used: a simple sinusoid at 5 Hz; sinusoidal vibration at 5 Hz with random amplitude; and random vibration frequencies ranging from 4 to 12 Hz. Subjects were required to perform either visual or auditory monitoring tasks during exposure to the vibration.

C. Holland et al. used a simulator with an electrically controlled, hydraulically powered feedback system. The input to the system was a voltage supplied by an analog computer. Thirty-nine "rides" (combinations of movement conditions) were made up of combinations of 8 or 32 sine-wave components. Frequency components were spaced at intervals of 0.25 Hz with a frequency range between 1 and 9 Hz. One "ride," at a gain setting of 1.50, was used as a standard for comparison. Subjects were told that the value of this standard was 10, and that other rides were to be quantified in terms of "roughness" as compared with this value. Each ride lasted 60 seconds, with the standard presented first. Background noises ranging between 90 and 94 dB were included under all experimental conditions.

Human Sensitivity to Vibration (Reiher-Meister Scale)  
(Australian Study)

Frequency (Hz)

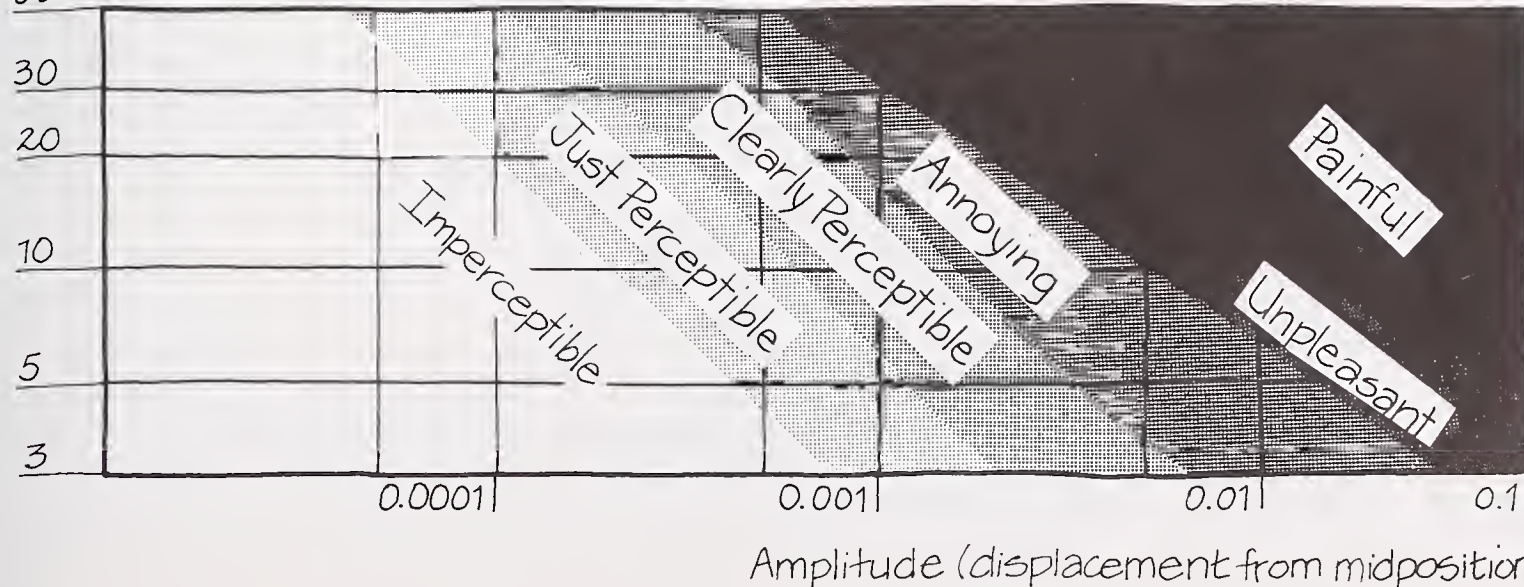



H. Jacklin and G. Lidell followed up initial studies performed on a vibrating platform with tests in passenger vehicles. An accelerometer was placed on the rear seat of a conventional five-passenger automobile.

The subjects were tested under a variety of conditions (three roads, three loadings, three tire pressures) in order to determine when movement in the left rear seat was judged "disturbing" to the passenger. The test car was started slowly and accelerated gradually, until this condition was reported.

Van Deusen had subjects rate the "ride discomfort" of a truck moving on 21 different paved and unpaved road surfaces. The ratings were made by regulating the sound intensity of white noise until it "matched" the degree of discomfort associated with the ride. Physical measurements were made by means of pickup transducers located on the vehicle seats. Time records of vibration during acceleration were obtained for each vehicle in three mutually perpendicular directions for each noted condition.

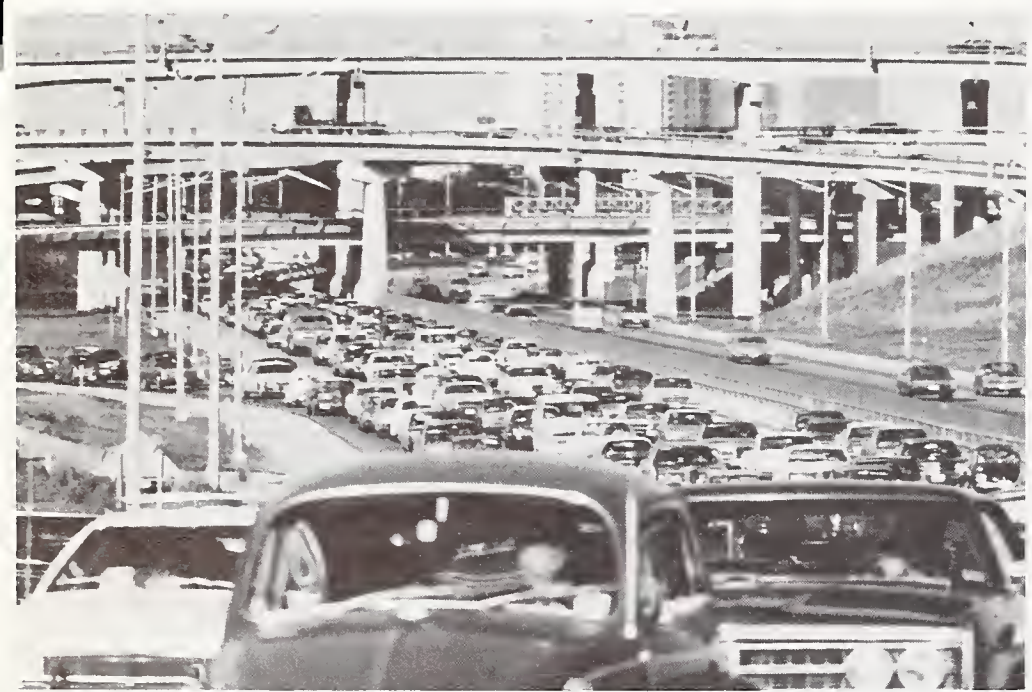

Vibrations Experienced in Automobiles (NBS)

### Summary of Findings of "Movement" Studies

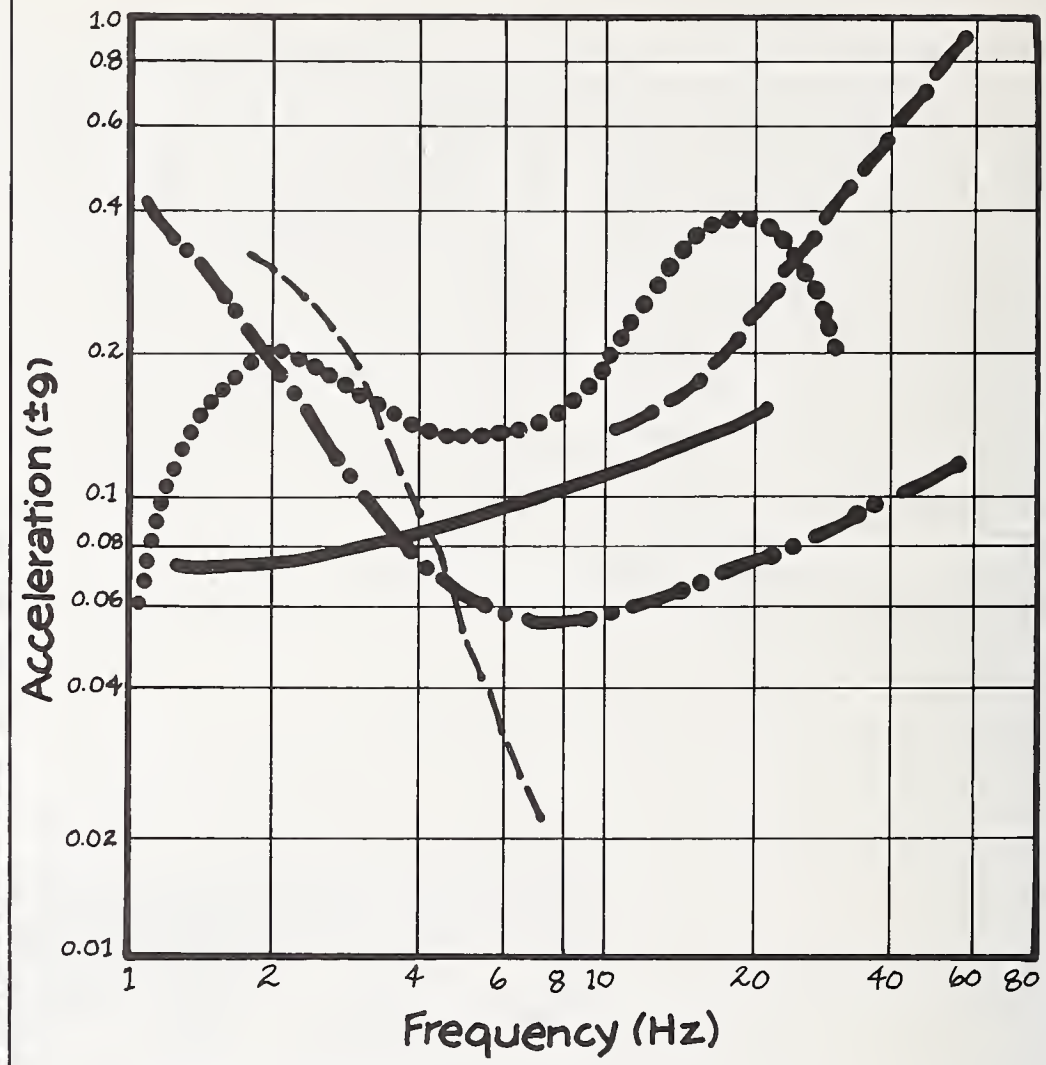

- Reiher-Meister
- Parks
- - - Jacklin
- Helberg-Sperling
- · - Constant



## Performance Studies

The studies described have employed the procedure of having subjects make judgments concerning the noticeability and/or discomfort caused by motion. More recent studies performed for military and space missions have been designed to determine the effects of vibration primarily on the ability to perform tasks. A number of these investigations will now be described to indicate the type of performance measures obtained.

A very common task is reading and it therefore has received considerable research attention. J. Dennis, for example had subjects read a series of 2-digit numbers (at a visual angle of 5 minutes of arc, distance 10 ft. 10 in.) (3.3 m) while seated on a vibration table. Subjects were exposed to "light" (5-27 Hz; amplitude 0.1 in. to 0.003 in. (2.5 mm to 0.076 mm)) and "heavy" (7-90 Hz; 0.1 in. to 0.003 in. (2.5 mm to 0.076 mm)) vibrations. Visual performance was significantly affected by all but one of the conditions. As expected, heavy vibrations were responsible for more errors than light ones.

M. Schmitz examined the effects of vibration on a number of tasks. In his study, 18 subjects were seated on a contour wooden chair, mounted on a shake table which was vibrated as follows: 0.15 g and 0.30 g at 3.5 Hz, and 0.18 g and 0.35 g at 2.5 Hz. Subjects first performed a driver simulation task for 15 minutes. Then the vibration conditions took place. Measurements taken were: visual acuity, using Landolt rings; a hand tremor test which required the subject to keep his index finger steady; and a test to maintain constant foot pressure. The findings of this study were inconclusive—consistent effects were not apparent.

Since noise often accompanies vibration as an environmental problem, many studies have been conducted to determine their combined effects (as well as their individual ones) on task performance. R. Hornick examined the effects of noise and/or vibration on simple reaction time, responding to a simple signal as soon as possible. The experimental conditions were: control (no noise or vibration); noise alone (87 dB); vertical vibration alone (3.5 Hz at 0.30 g); and combined noise and vibration. The task of the subject was to press a button as soon as possible after the onset of a red signal light. This study also did not produce any systematic findings attributable to the experimental conditions.

The tasks most frequently examined in vibration studies have concerned tracking. Tracking involves following a target in two- or three-dimensional space with reference to an observer. The observer is required to make a continuously changing response to a continuously changing "error" signal which is fed back to him. Tracking tasks have been primarily designed for those responsible for monitoring and/or flying aircraft (and more recently, space vehicles). An example of a tracking task is as follows. A cathode-ray oscilloscope is used as a display device. The experimenter presents a signal (which moves in a manner preprogrammed to suit experimental purposes) on the display. The task of the subject is to control the movement of the signal by means of a joystick (or other control) in accordance with experimental instructions, for example, *center the target signal on a vertical line on the display*. The complexity of tracking tasks can be varied readily (e.g., size, speed of movement, delay of feedback, number of other possible signals, etc.), thereby making them a very important and versatile research approach for many problems, but so far limited in M/E studies.

## Conclusion

While comparatively few studies have been performed which deal with the effects of building movement on people, their quality has generally been high. Furthermore, the research approaches have been quite varied, ranging from performance to attitude measurements, under controlled laboratory and field conditions.

Perhaps the first requirement for M/E researchers is to determine how widespread and important the building movement problem is. One approach could be to employ Reed's procedure of conducting user surveys of lightweight high-rise buildings, while at the same time making physical measurements of the building. Then, important problem areas could be researched employing semi-realistic yet controlled procedures similar to those developed by Yamada and Goto. The findings from this research could then be used and tested in new buildings, as a means of improving current criteria used for building movement.





*Textures (NBS)*



# 17

## The Cutaneous Environment— Skin Senses

### Tactile Information

- Pressure Sensitivity
- Temperature Sensitivity
- Shape vs. Texture
- Texture

### Conclusion

## Distribution of Vibratory Sensitivity

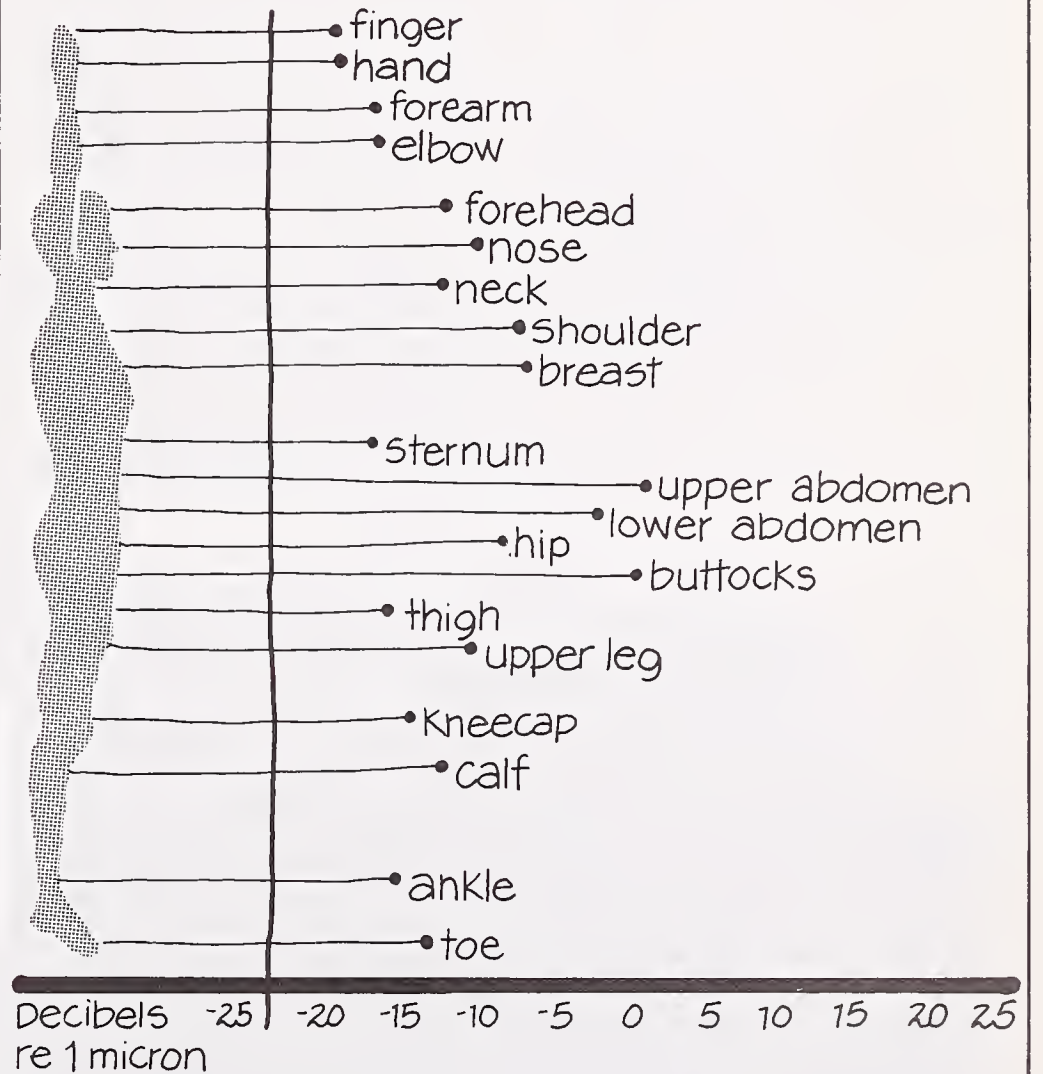

Consider the earliest experiences that we have—those dating from childhood. An infant, when confronted with an object, touches, handles, observes, and ultimately tries to put most objects in the mouth. This series of activities enables the infant to experience objects in many ways, each one making a contribution to overall understanding.

The childhood experience of touch has been a popular research approach in this study area. The habit of holding and touching objects never leaves us, as indicated by the “don’t touch” signs which appear in museums, zoos, and other places where novel objects (or species) can be found. Touch is an especially important source of information in the experiencing of form and texture, two attributes of special importance in buildings.

Information about form and texture is not obtained exclusively by touch. Rather, visual phenomena are also important information sources. For example, when we enter a building, within a short distance we often encounter several different surface characteristics. The street pavement, steps, doormats inside and outside of an entrance, the finished surface of the interior, and carpets frequently have different and distinctive textural features which we become aware of by seeing and walking on them.

Cutaneous experience is therefore dependent on two sets of interrelated experiences—visual as well as tactual ones. In a sense, the information gained by each sensory system strengthens that obtained by the other, thereby making each perception more vivid than would otherwise be the case.



*Study of Tactile Response (NIH)*



*Museum Exhibit—To Be Touched (NBS)*

Although only form and texture have been mentioned so far, the skin senses provide a broad range of information concerning our environment, and the objects around us. Studies have shown the skin to be sensitive to heat (cold), vibration, pain, and even light. The complexity and variety of problems addressed in this research area are indicated by the lack of a generally accepted name for the discipline. Among the terms used by researchers of the skin senses to describe the topic are “haptic,” “cutaneous,” and “tactile.”

Our understanding of touch sensations is comparatively limited. The question of which nerve endings in the skin (and deeper-lying tissues) respond to common touches and pressures is still far from settled. It should therefore not be surprising that the phenomena experienced are even difficult to classify. A skin characteristic generally determined is that it is not uniformly sensitive. This characteristic has been noted by examining the surfaces of different parts of the body.



Three separate sets of responses have been classified under the skin senses: one for pressure reception, one for pain, and the last one dealing with temperature changes.

The problems typically addressed by researchers have dealt with determining the physiological basis of touch sensations and the sensory limits (and capabilities). Another research area has been to determine the relative importance of touch as compared with other senses as a function of age (especially in children). A limited number of studies have been conducted to determine the potential of touch as a means for communicating (braille, informational coding procedures).

We have been only partially successful in our attempt to find studies of direct application to building-related problems. However, the research methodologies employed in the investigations are sometimes applicable to building design problems.

## Tactile Information

The skin senses have been looked upon as a potential means of communication under special circumstances. For example, doorknobs in public buildings are sometimes coded by having a rough surface to indicate that they are exits to a building. This coding device enables blind people to select the appropriate pathway to safety in emergency conditions.

In the design of aircraft controls and displays, researchers have examined the skin senses to determine how they might be used to augment the eye and the ear, which are sometimes overloaded with information. That is, more information is presented visually and aurally to pilots than can be handled efficiently by them. For many years the skin senses have been employed as a means of conveying information to blind people. This general problem area has been explored in some depth to devise techniques which are more effective than braille writing for transmitting information.

Although various parts of the body have been used as sensing organs, the fingers and the hands have received the most research attention. T. Austin and R. Sleight wanted to determine how accurately familiar forms could be identified when touched with the index finger. They used numbers, letters, and geometric forms approximately 1/2 in. (1.3 cm) in size, which were cut from masonite. (Twenty-five of the forms were readily identified, but only when the subject was permitted to move his finger.)

The design of control equipment for aircraft was influenced by the ability of people to recognize different shapes. E. McCormick (human factors researcher) describes the problem as follows:

*At certain times in piloting the aircraft the pilot is as busy as the proverbial one-armed paperhanger with the seven-year itch. Since it is important that the pilot's operations be simplified as much as possible, it was believed that if control lever knobs could be recognized by touch, there would be fewer things that the pilot would have to look at.<sup>1</sup>*

The problem was studied by designing a variety of control knobs and having subjects identify them while blindfolded. The objective was to determine how many different shapes could be used, without too many confusion errors. Eleven shapes were found to be the maximum number which could be readily identified.

## Variety of Switch and Knob Shapes

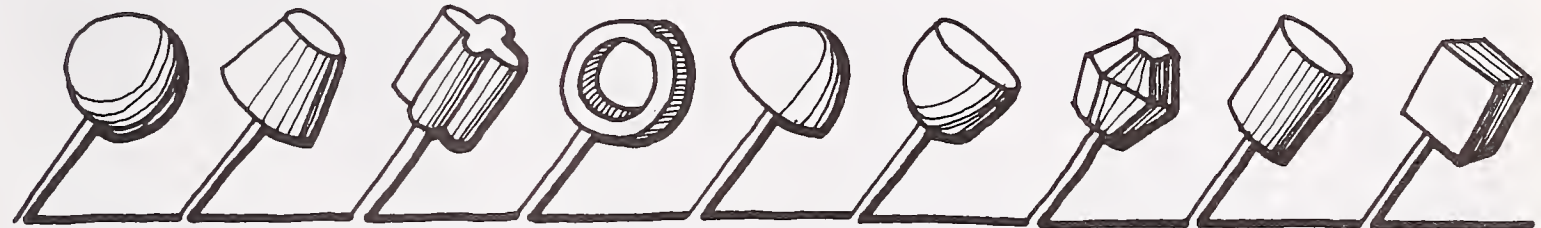

## Toggle Switch Shapes



## Knob Shapes

<sup>1</sup> E. J. McCormick, *Human Factors in Engineering and Design* (New York, 1976).



G. Hawkes (psychologist) conducted an investigation to determine the effectiveness of electrical stimulation to the finger and the hand as a means of communication. Electrodes were attached to the index finger and the palm. Several different levels of intensity were used, and the durations ranged from 50 to 1500 msec. Subjects could distinguish four intensity levels and four durations, but found it easier to distinguish among durations than intensities.

J. Bliss et al. performed a number of studies to devise tactile means of communications. In one study, subjects had a series of airjet stimulators fastened to their fingers. The experiments consisted of the presentation of patterns of air stimulation on the fingers which were to be interpreted by subjects in accordance with instructions given to them beforehand. The subjects were able to perform the task this way as well as they did visually, but more training was required.

Another study by the same authors employed an array of vibrators to provide feedback information to subjects who remotely manipulated a set

of tongs. By using this device, subjects successfully completed a number of simple tasks, e.g., lifting objects and opening latches.

### Tactile Research Using Air Stimulation (Bliss et al.)

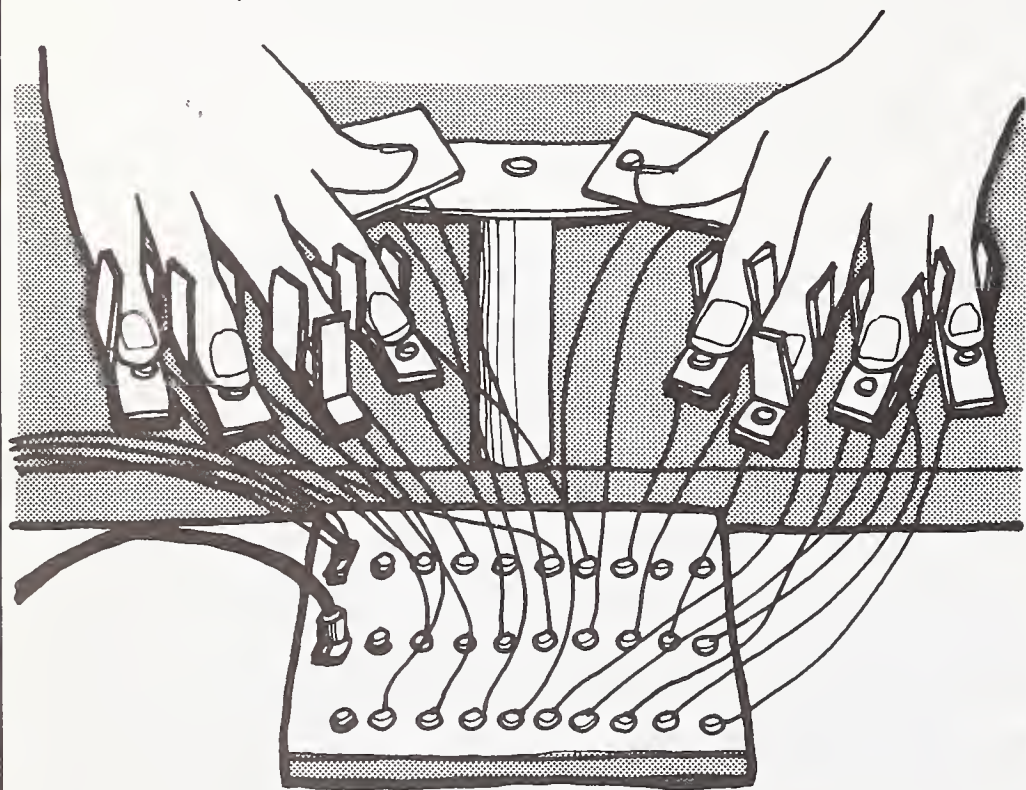

Array of airjets, connecting tubes, and hand holder used to present tactile dot patterns.

### Vibration Feedback for Remote Movement (Bliss et al.)





# Magnitude Functions for Apparent Intensity of Vibration (finger)

Magnitude Estimation

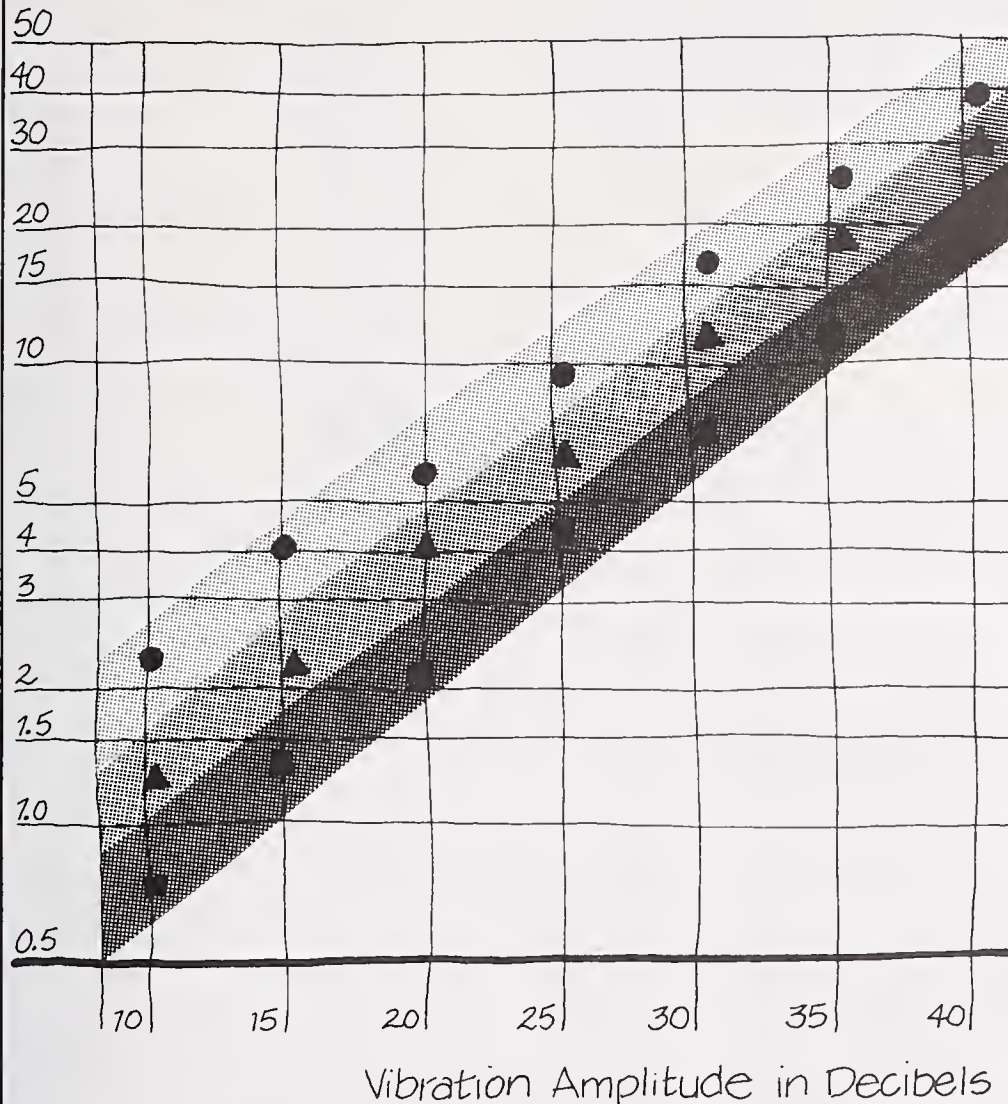

- vibrating rod held between fingers
- middle finger on vibrating button, at right angle to vibration direction
- middle finger on button, parallel to vibration direction

A. Burrows and F. Cummings developed an aircraft column grip which was modified to house an electrically driven device. When an aircraft warning sensing system was activated, the device vibrated at 268 vibrations per minute. Subjects used this device and a visual warning signal in a study to determine their relative effectiveness. The tests showed that both methods of presenting danger signals gave comparable results.

In chapter 7 we mentioned the study by Bach Y Rita et al., who employed space age technology to enable blind people to "see" through their skin.

Television scan signals have been used to switch an approximately one-foot square array of tiny vibrators pressed against the soft skin on the blind subjects' backs. After approximately 10 hours of training, they were able to recognize familiar objects viewed by the television camera. With additional experience the students could discriminate between people in a room, follow movements and even discover visual effects, such as perspective and shadow.<sup>2</sup>

The studies we have mentioned thus far fall into the applied research area. Now, we will examine the more fundamental work performed in this study area.

## Control Column Employed by Burrows & Cummings

(1956)

Frequency : 268 vibrations/min. at 30 volts

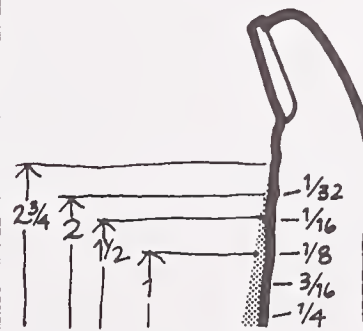

Away from Pilot

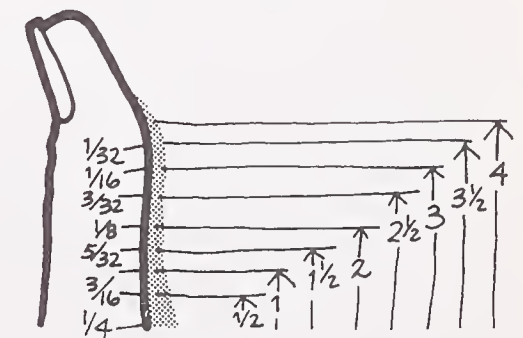

Toward Pilot

<sup>2</sup> F. A. Geldard, *The Human Senses* (2nd ed.), (New York, 1972).

## Pressure Sensitivity

Since the skin surface varies considerably with respect to sensitivity, one early approach was to develop sensitivity "maps." This was accomplished by using a rubber stamp in the form of a square (20 mm by 20 mm, containing 420 squares). The center of each square imprinted on a body surface was then stimulated. Because of the varied sensitivities of the skin surface, stimulation could be presented in many forms:

mechanical, thermal, electrical, and chemical means have all been employed. Similarly, for the arousal of "touch," "contact," and "pressure" sensations, solids, liquids, and even air blasts are used.

The oldest and best known technique was developed by M. von Frey (physiologist). He used a series of straight (animal and human) hairs of different diameters, fastened to a wooden handle. The diameters of the hairs were measured and the force exerted computed. The threshold was then determined for a series of bodily regions, by determining the "weakest" hair which was noticeable to the subject, by its touch.

S. Stevens (psychophysicist) collected judgments of the magnitude of vibration in three different ways: (1) a vibrating rod held between the fingers, (2) a vibrating button upon which the finger rested at a right angle to the direction of vibration, and (3) on the vibrating button, with the finger held parallel to the vibration.

He presented the subject with a vibration of moderate amplitude, and gave it an arbitrary value of 10. This number served as the standard for making further estimates. For example, one which appeared to be twice as strong would be scored as 20; one half as strong, as 5.

## Temperature Sensitivity

Chapter 14 dealt with the thermal environment. Here we will briefly mention one aspect of temperature—skin

sensitivity. The temperature sensitivity of the skin has been examined by employing the grid technique mentioned earlier. The Dallenbach temperature stimulator has been a much used instrument in these studies. The instrument has a contact point which is limited to 1 mm, and whose temperature is controlled by a rapid flow of water. It has the added feature of controlling pressure by means of a spring mechanism at the bottom.

## The Dallenbach Temperature Stimulator

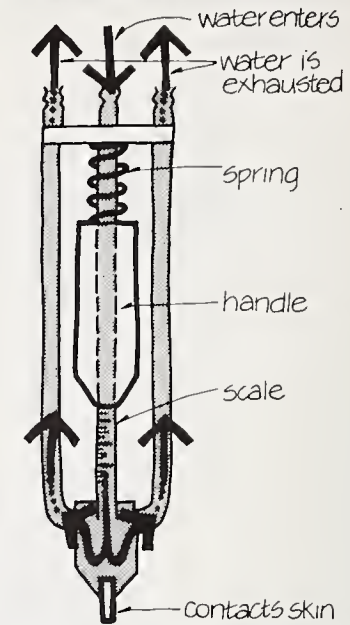

## Distribution of Cold and Warm Spots Found on Upper Arm

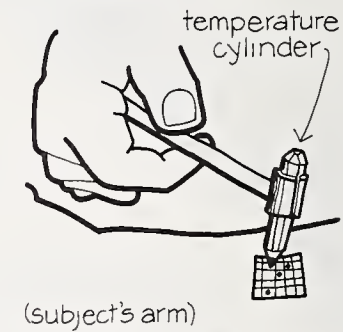

○ cold spot  
● warm spot

Day 1

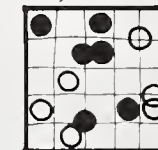

Day 4

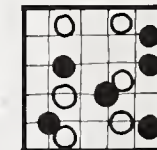

## Vibratory "loudness" Contours (from Verrillo)

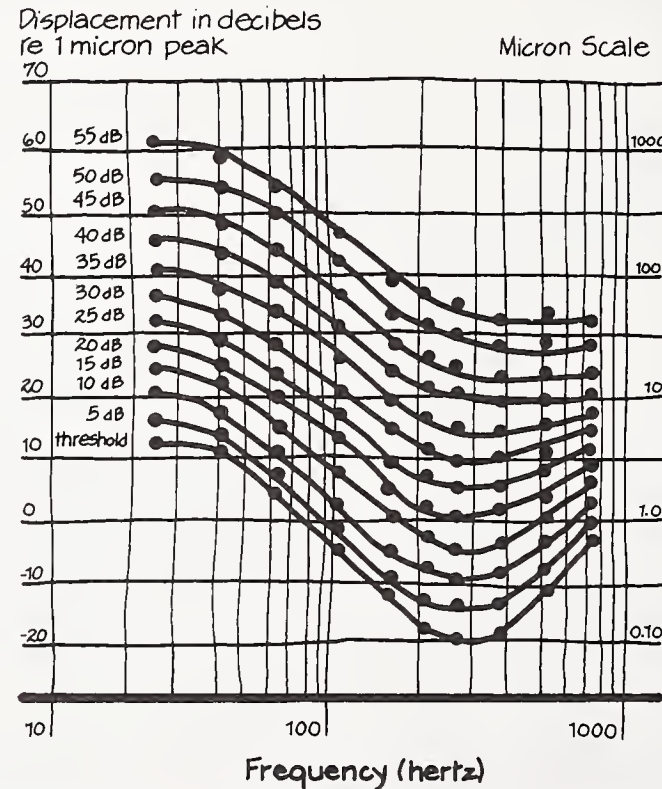

Estimated loudness as a function of frequency of vibration. Intensity (in decibels SL) is referred to threshold for 250 Hz.



## Shape vs. Texture

A number of studies have been designed to determine the relative importance of each of these attributes of materials. One such investigation, performed by C. Gliner was designed to determine how well children in kindergarten and the third grade discriminate differences in shape and texture. In particular, Gliner was interested in finding out whether there was any identifiable trend in preferences with the passage of time. Gliner used a classical psychophysical procedure to collect her data. She describes her approach as follows:

*The conditions of the experiment were defined by the particular stimuli presented... The texture stimuli were a series of sandpapers of different coarseness; the shape stimuli, a graded series of ellipses. The texture series consisted of 15 grits (24-500) of sandpaper. The particular grits were chosen because they represented the widest range and maximum number of values available in one kind of abrasive.*

*The shape series was composed of 15 ellipses which ranged from a circle 2 inches in diameter to an ellipse whose major axis was 3 3/4 inches and minor axis was 1/4 inches. The sum of the lengths of the major and minor axes remained constant at 4 inches for each shape throughout the series.*

*Both the shape and the texture series of 15 pairs were presented in two contexts. The texture pairs were presented side by side and either covered the entire perceptual field (Texture condition) or*

## Shape vs. Texture – Study of Sandpapers (Gliner)



texture 1

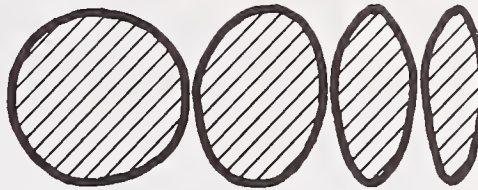

texture 2

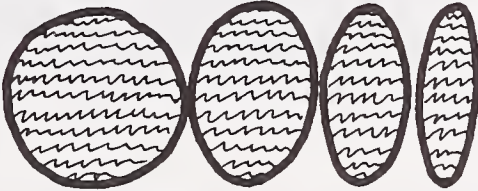

texture 3

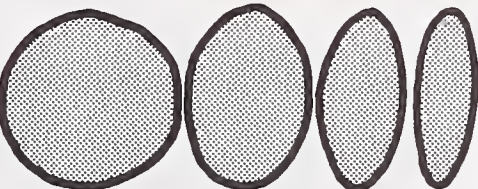

texture 4



texture 5

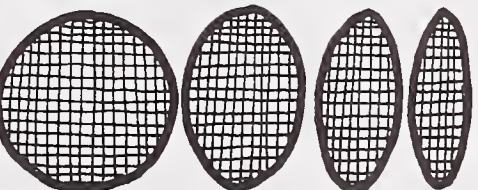

texture 6

were confined to the top of a constant elliptical shape (Shaped-Texture condition).

*Subject faced a 30 x 24 inch screen and reached his hand through a curtained 5 1/2 x 6 inch hole to feel two stimuli. The stimuli were mounted on a turntable 30 inches in diameter. Each standard was flanked by two different comparison stimuli, but a hand guide restricted the subject's movements such that he could feel only one pair of stimuli (the standard and one comparison) at a time. The subject was told that he would have to feel the two things and say if they were the same or different from each other.<sup>3</sup>*

Gliner found that older children generally performed better than younger ones, but there was no evidence that either shape or texture changed in relative importance as environmental cues, as a function of age.

A. Siegel and B. Vance also studied children's preferences for touch and sight. The apparatus used in the study was a wooden tray with three wells. Inside the wells were spheres and cubes of different colors, sizes, and textures. The child had the opportunity to view and touch the samples; he then judged which two (of a group) were the "same." Texture ranked last among the other attributes—color and shape.

<sup>3</sup> C. Gliner, "Tactual Discrimination Thresholds for Shape and Texture in Young Children," *Journal of Experimental Child Psychology*, 5 (1967).

## Texture

D. Katz, the Gestalt psychologist mentioned earlier (chap. 11) employed the same attributes that he did when examining color to describe touch sensations.

- Surface—discriminations are made by moving fingers against an object. Object is solid, oriented and located spatially.
- Something which fills a space—encountering a fluid material such as water or an air stream, which is not oriented or localized in space. Its resistance is elastic. Discriminations such as elasticity, stickiness, and viscosity can be made.

- Film—touching an object with thin rubber gloves or through a very thick film surface (0.0105 mm).

Katz then tried to determine how long it would take subjects to identify materials using only the sense of touch in their fingertips. He collected approximately 40 samples of material (15 cm x 15 cm) and mounted them on a wooden plate. Examples of the types of materials used are: linens, velvet, blotting paper, sandpaper, woolen cloth, leather. Subjects were asked to make two judgments: (1) when something was felt, and (2) when the material was recognized. (Katz hypothesized that every material has a "thermal Gestalt" which is used for recognition.)



M. Yoshida conducted a study which essentially followed up the earlier investigation by Katz. Yoshida employed 50 materials similar to those used by Katz, and had subjects rate the materials on a series of 7-point semantic differential scales. No particular instructions were given as to how the task should be performed. The subjects handled the material samples by *stroking lightly on the surface, picking them up by the tip or crumpling them in the hand at times.*<sup>4</sup>

Yoshida summarized his major findings as follows:

*The results clearly indicate the opposition between fibers and materials. The most important physical dimension which differentiates these two groups is specific gravity (not weight).*

*Tactual impressions under colder conditions are nearly the same as those under warmer conditions. And tactual impressions without participation of vision are nearly the same as those in the main experiment with vision.*<sup>5</sup>

Of interest to both designers and people who use buildings are the texture and shape of objects and surfaces.

### Cutaneous Semantic Scale of Materials (after Yoshida)

(adjective) "very" ← "slightly" → "very" (adjective)

substantial ferrotungsten cork plug empty

stiff flowerpot absorbent cotton not stiff

sharp swab absorbent cotton dull

painful swab foam rubber painless

hard cast iron foam rubber soft

viscous dough glassplate runny

glossy candle wax ferrotungsten not glossy

brittle cast iron stainless steel not brittle

clean silk ferrotungsten dirty

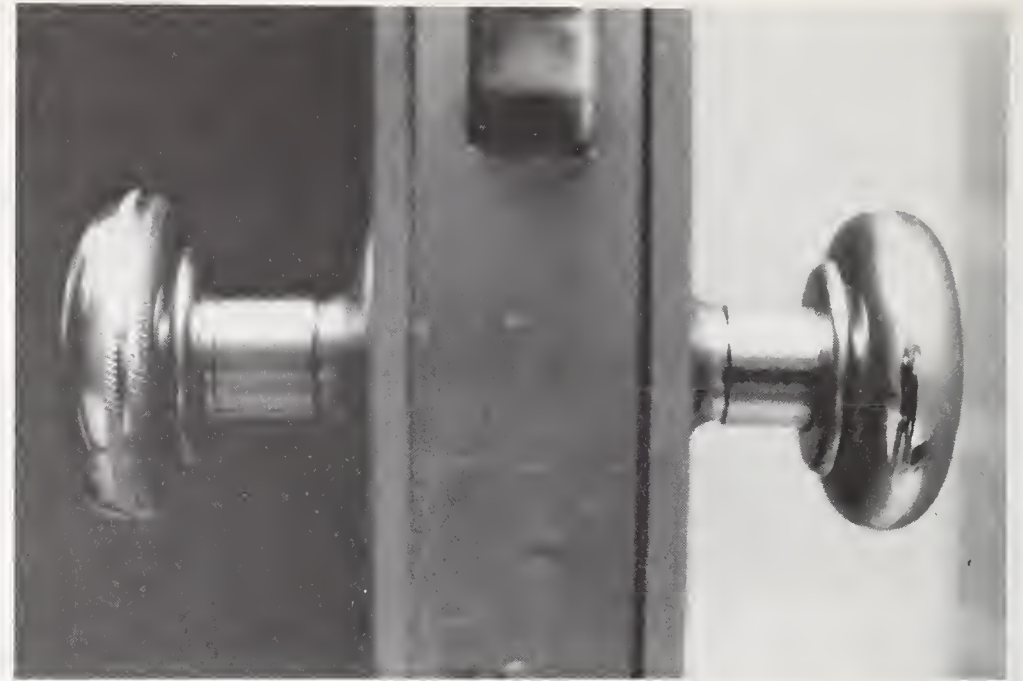

Textured Doorknob—Exit (NBS)



Tactile Signs (Seton Name Plate Corporation)

<sup>4</sup> M. Yoshida, "Dimensions of Tactual Impressions," *Psychological Research*, 10 (1968).

<sup>5</sup> Yoshida



## Conclusion

The study of the tactile environment has not received sufficient attention by researchers. Information for practical as well as aesthetic purposes should be compiled as an aid to design. For example, consider tactile coding of information as an aid for blind people to find directions in buildings (surface textures on walls or floors). Such designs can also prove valuable to people with normal vision, and when vision is impaired by smoke, blackout conditions, or loss of power during fire emergencies.

In this, and the preceding part of the work, we have reviewed the research approaches used to study the "sensory environment." Each sensory area has been described separately, with few studies dealing with more than one modality. There are two reasons for organizing this study in this way. First, the preponderance of sensory research has been parametric and therefore this organization scheme is a logical one. A limited number of researchers have examined the effects of combined environmental attributes, such as the effects of different noise and vibration levels on performance. However, in these instances the research methods used typically consisted of a combination of traditional ones, not new approaches developed for combined sensory studies. Since the methods are already described in one of the chapters, we saw no reason to do so again.

## Man's Senses and the Energies That Stimulate Them (Van Cott)

Sensation	Sense Organ	Stimulation	Origin
Sight	Eye	Some electromagnetic waves	External
Hearing	Ear	Some amplitude and frequency variations of pressure in surrounding media	External
Rotation	Semicircular canals	Change of fluid pressures in inner ear.	Internal
	Muscle receptors	Muscle stretching	Internal
Falling and rectilinear movement	Otoliths	Position changes of small, bony bodies in inner ear.	Internal
Taste	Specialized cells in tongue and mouth	Chemical substances	External on contact
Smell	Specialized cells in mucous membrane at top of nasal cavity	Vaporized chemical substances	External
Touch	Skin	Surface deformation	On contact
Pressure	Skin and underlying tissue	Surface deformation	On contact
Temperature	Skin and underlying tissue	Temperature changes of surrounding media or objects, friction, and some chemicals.	External on contact
Pain	Unknown, but thought to be free nerve endings	Intense pressure, heat, cold, shock, and some chemicals	External on contact.
Position and movement (kinesthesia)	Muscle nerve endings	Muscle stretching	Internal
	Tendon nerve endings	Muscle contraction	Internal
	Joints	Unknown	Internal
Mechanical vibration	No specific organ	Amplitude and frequency variations of pressure	External on contact

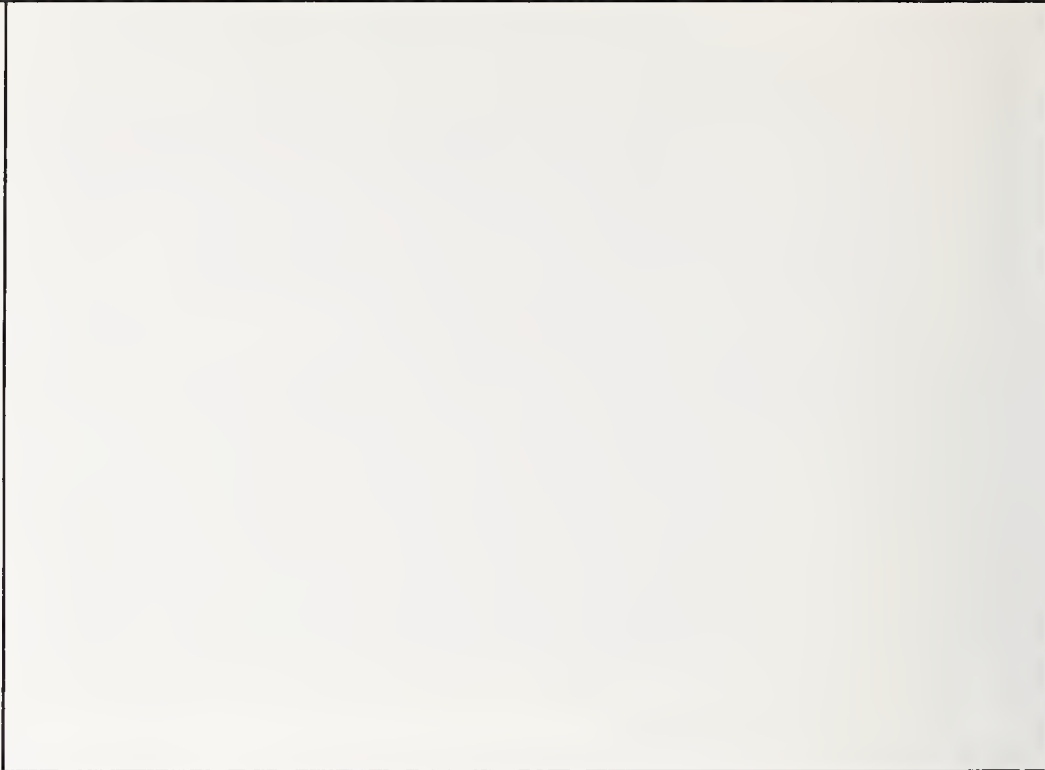



# Part VI

---

## Summary

# 18

---

## Summary, Conclusions, and Directions

M/E Discipline Needed Now

Development and Application of User Data

Using Existing Information

Problem Areas

Buildings often do not properly serve their primary users, the occupants. This is the premise which underlies this work. One main reason for this is that user information employed in building design is not adequate. How does a building's design influence the behavior of people? If we better understood this relationship and fed the information into the design process, we would have buildings that better carry out their intended functions. Improved user information is especially important during design and post occupancy evaluation.

Almost half a century has passed since Walter Gropius first called for better human behavioral data. The need is still largely unmet. Why?

The behavioral sciences have for over a hundred years researched problems of an M/E nature. Countless sensory studies have been made to trace the links between environmental characteristics and sensory responses. Unfortunately, however, the studies have been concerned less with the midrange of conditions found in buildings than with environmental extremes encountered in military and space situations. Moreover, researchers have explored basic sensory processes (such as auditory and visual thresholds) rather than responses to environmental stimuli found in buildings. Human factors studies have dealt less with everyday design problems than with man/machine requirements. Hence M/E and other social science disciplines have uncovered a wealth of information of potential value in building design, but the data are often

either hard to find or not directly applicable.

Although M/E studies *per se* go back to the late 1930's, with the work of Svend Riemer (see chap. 19), the past decade has accounted for the bulk of such studies. Limitations are evident. The typical M/E study is narrowly defined, being conducted to solve a particular design problem. Other architects or researchers are hard put to use the findings due to a lack of appropriate documentation on how the studies are conducted. Research methodology is often not well described which makes it difficult or impossible to evaluate the findings, implications, and/or conclusions. Another problem in M/E research is the widespread and often indiscriminate use of survey questionnaires and semantic differential scales, with little evident relationship to buildings and building design factors. The findings of studies of this kind are in the form of attitudes, judgments, and feelings about an environment which is not described in a meaningful way. They do not tell the architect what is "good" or "bad" design practice.

A barrier to both traditional social science research and M/E studies has been the absence of generally accepted methods for making M/E observations and measurements. How relevant are well-developed methods to the solution of M/E problems? The record is vague on this point. As for the M/E state-of-the-art, the quality of information varies from study to study, depending on the researchers' skills.



Another block in the development of user data is architectural tradition. For the most part, architects want to spend as little time as they can in uncovering such data. Much user data therefore comes from indirect sources—codes, standards, and guidelines prepared by regulatory and technical organizations. While these “requirements” (lighting, noise, safety-related data, etc.) are often said to be based on behavioral investigations, their research basis is often uncertain, which can make for questionable design recommendations.

The other route—discussions between the architect and client—too frequently serves as the primary means for developing user-related data. The building user is seldom an important contributor. The quality of information therefore largely depends on the personal experiences of the architect and client and on their ability to apply these experiences to a given design problem.

Architectural training in most instances has tended to underestimate the importance of ultimate building users, and the relevance of behavioral research to design. Consequently, the architect approaches the need to define user requirements from a non-technical standpoint, relying largely on personal preferences and experiences. The information in technical behavioral research publications is therefore hard for the architect to understand or interpret. Ignorance of potentially valuable existing sources has led to undue expenditures for better user data. For

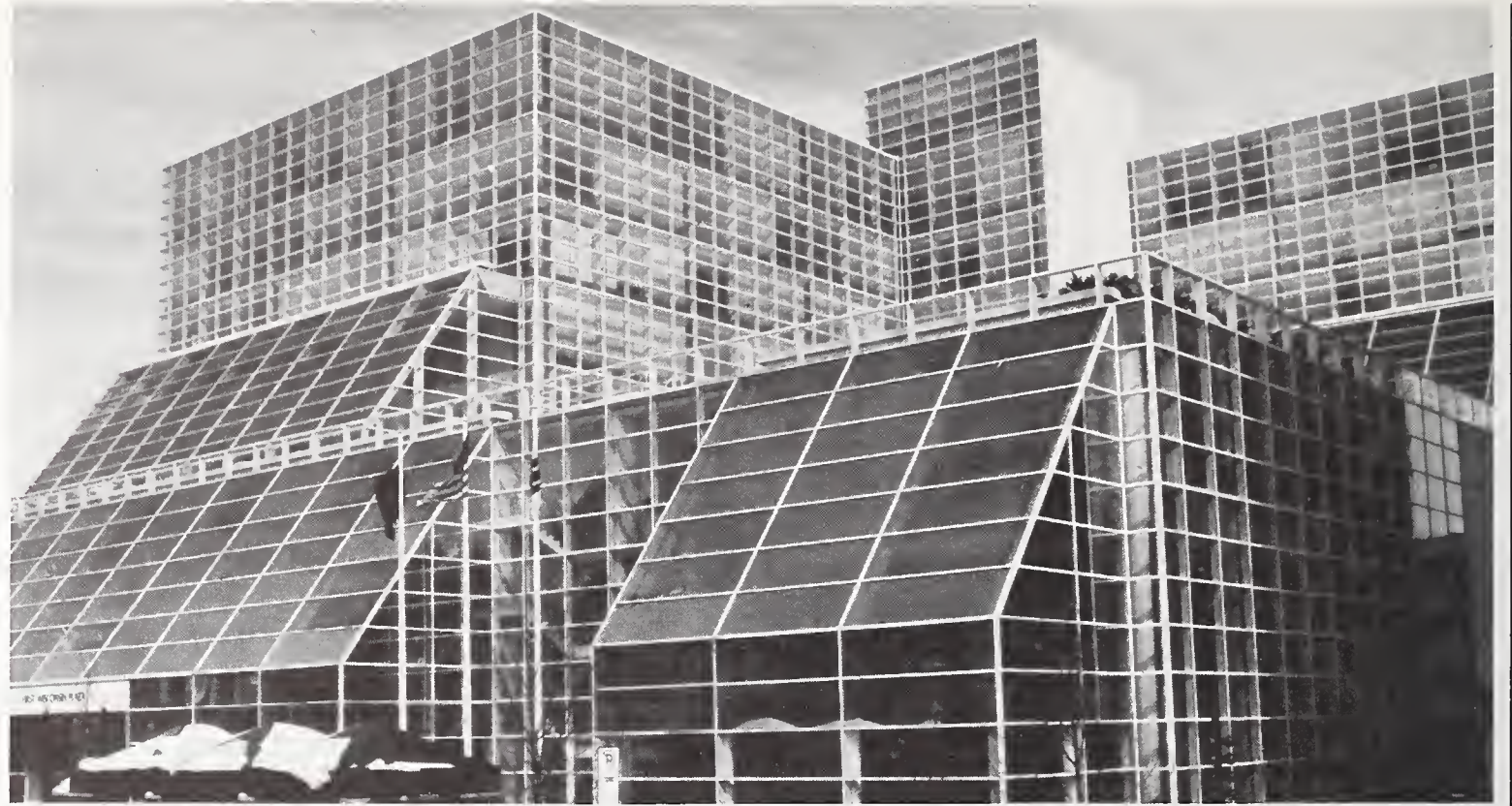

*Building with Solar Collectors (R. Hastings)*

the most part, however, the architect and client seldom place a high priority on development of such information.

The informality of the design process has served to place the need for and development of user information in a secondary role. Furthermore, although post occupancy evaluation is cited as a step in the building process, studies of this type are rare. As a result, architects designing new buildings have limited benefit of past user experiences.

Interestingly enough, the current information explosion has intensified the value of user requirement data for design. For example, energy and materials shortages are likely to intensify. The increasing costs of these resources have contributed toward a new look at building costs. Thus, long-term (life cycle) costs in terms of energy, money, and space adaptiveness are receiving a lot of attention. The building community now finds that a major expense over the lifetime of a building is the salaries of its users and operators, which in turn has led to curiosity as to the effectiveness of buildings for performing required activities.

Since the architect is now likely to concentrate on a more efficient use of materials, energy, and space, more nontraditional design solutions are likely. This may make new unfamiliar designs less acceptable to building users (e.g., different surface materials, less space, natural ventilation, smaller windows, etc.).



One trend is the design of a "permanent" building shell, with flexible, interior elements to accommodate a variety of activities. Buildings are conceived as having a variety of potential uses. This definition of buildings is similar to the outlook of human factors researchers who examine problems from a systems viewpoint, with man as part of a man/environment or man/machine system.

## Flexible Space Use



activity designed for...



...activity used for

A recent study of energy use by Princeton University<sup>1</sup> illustrates the need to think of a building from the standpoint of a dynamic system, with human components rather than a passive structure. The investigation of energy usage in a town house community (Twin Rivers, New Jersey) showed that energy cannot be saved merely by upgrading the thermal efficiency of buildings (e.g., adding insulation). Rather, the energy-related activities of residents were found to strongly influence the amount of energy consumed. Other studies have shown that maintenance, such as cleaning floors, has consumed more energy for lighting by a handful of employees than was consumed in a fully staffed office building during a normal work day.

The research at Twin Rivers illustrates the involvement of the general public in both user requirements and major social issues. The consumer and environmental movements reflect the average citizen's growing awareness of and sensitivity to issues which touch his day-to-day life. Programs are now proposed which are meant to encourage U.S. homeowners to upgrade their dwellings with respect to overall quality and/or energy use. Increased costs of services and lack of skilled craftsmen have also encouraged homeowners to be more self-reliant. All of this has served to heighten the awareness of people to the way they interact with their built environment.

<sup>1</sup> C. Seligman et al., *Psychological Strategies To Reduce Energy Consumption: First Annual Progress Report* (Princeton, 1976).

## M/E Technical Issues

Topic	Requirement
<b>Models</b>	Determine adequacy of physical science approach Develop improved models
<b>Measurements and Observations</b>	Improved methods Complex environments Psychophysical approaches Emotions Aesthetics Responses Performance
<b>Characterization</b>	General population Special groups Aged Handicapped Children
<b>Analytic Elements</b>	Systems Subsystems Activities Tasks
<b>Processes</b>	Interdisciplinary cooperation Designing by team Performance approach

The information explosion has spurred architects toward a team approach to practice. The many technical and regulatory issues that must be resolved in the building process have made it harder for a single person (or small group) to design other than modest buildings.

Team design allows architectural firms to employ social scientist specialists to meet user information needs as part of the design process, either on a consulting basis or as part of their permanent staff.

## M/E Discipline Needed Now

The time is right for an orderly development of information dealing with how people respond to buildings, i.e., for determining user requirements.

The task of developing high quality user information is huge due to the amounts of relevant subject matter and its complexity. Hence, architects and behavioral researchers should seek approaches directed to a systematic development of knowledge on M/E interactions. Instead of today's largely piecemeal, independent, and narrow studies of M/E problems, researchers should foster the steady accumulation of information available to all researchers and designers. This can be done by developing appropriate methods for making M/E observations and measurements, refining and standardizing them, thereby permitting one researcher to verify the findings of another.

We need a scientific M/E discipline. At present, this study area is more of a practitioner's art consisting of many studies tailored to answer specific questions. Lacking is the ability of researchers and/or architects to use findings for purposes beyond those being studied. A feature of a scientific discipline is the development of mathematical models and procedures so results may be generalized.

## Development And Application Of User Data

If M/E information is to help the building community, it should arise as part of the design process, with the user an integral part of that process. We should determine where, when, and what type of user data is required for each stage of design. We should plan for timely data collection, i.e., before design decisions are made which are likely to influence activities in the building. Bad design decisions made early may lead to poor performance for the life of a building.

User data must be developed to permit later evaluation. For example, if the requirement is for a "comfortable" environment, and comfort cannot be readily measured, then the adequacy of the design cannot be determined. Similarly, when requirements specify certain activities (e.g., being able to converse without raising one's voice), tests can be devised to determine whether the need is being met.

Such procedures should be documented if progress toward an M/E discipline is to be meaningful. The absence of records makes evaluation cumbersome and ineffectual, and makes it difficult for one architect to benefit from the experience of others. When these shortcomings are overcome, an accumulated body of M/E information will be available for all architects and researchers to use as the next generation of buildings is designed.

Ideally, buildings would be evaluated by means of simple, inexpensive instruments. For example, thermographic photographs of buildings supply information about insulation properties of a building shell, which in turn provide insight into thermal comfort. The dBA sound level meter is an instrument which gives a readout of

sound levels, weighted so as to conform with the hearing sensitivity of people. Before we can rely on instruments for measurements, however, we must know what should be measured, that is, the physical parameters which correlate with the ways people respond to buildings. This is the greatest task confronting M/E researchers.

## Development of Improved User Information

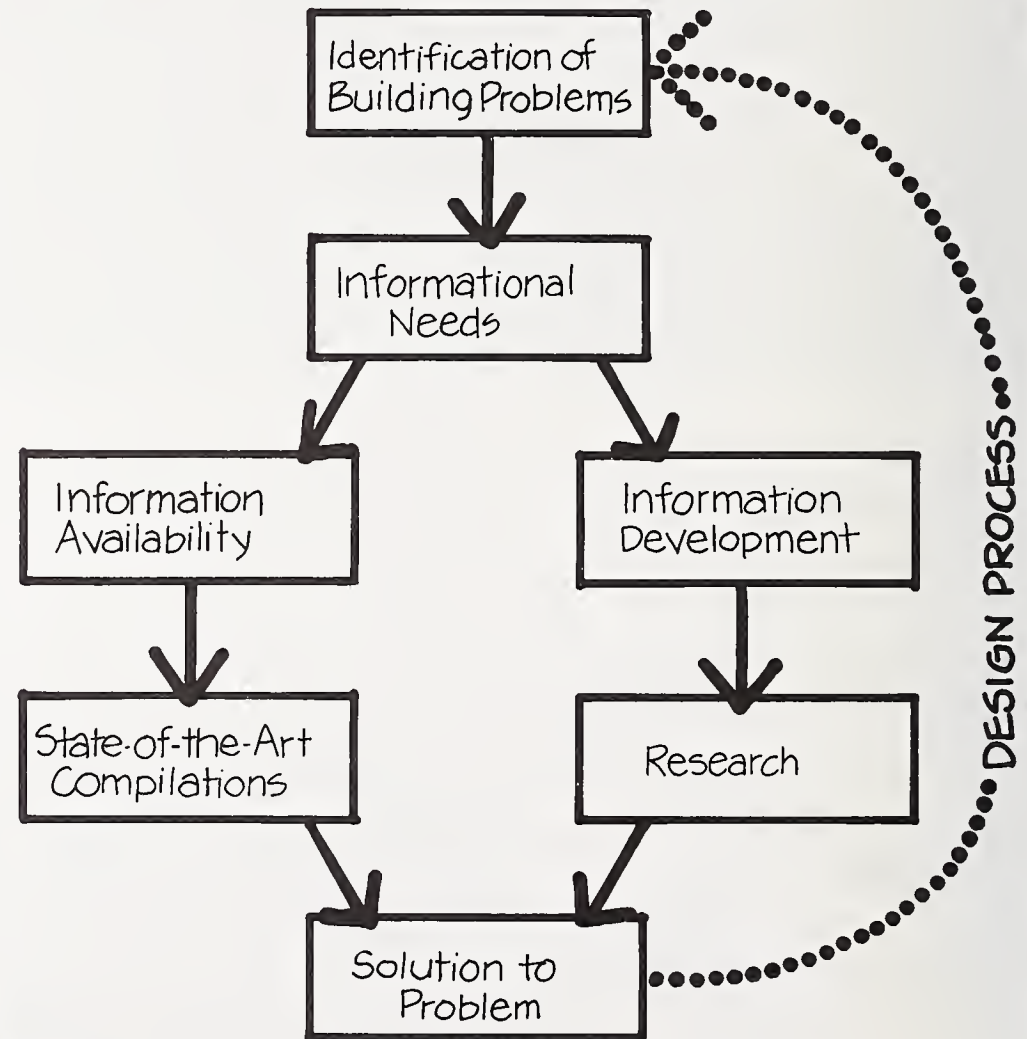



## Using Existing Information

To meet the immediate needs of the architect, better use must be made of information already available among the social science disciplines. One way to reach these data is to foster interest among these professionals in attacking M/E problems independently, as consultants, or as members of design teams. This way existing expertise and data can be profitably used.

Another way to address the problem is to make the architect familiar with behavior research approaches for developing user information. That is the central point of this work. By pointing up the links between design issues and observational and measurement procedures, we hope to have shown that the key to developing improved user data lies in the tools available to collect the data, namely *measurement methods*.

By explaining how, when, and why certain research methods are employed to solve M/E problems, we hope architects will gain an insight into the behavioral research process, thereby enhancing collaboration between the two professions. Although we have stressed research methodology, we have sought to show that the methods are merely the means toward the ultimate requirement of obtaining M/E information.

Even though we believe in measurement methods and the need for objectivity in dealing with user requirements, we feel that science should not be "sold" to the designer as a panacea. There is every reason to expect useful data in some areas, for example those dealing with sensory processes. However, many questions posed by the architect, such as those dealing with mood, pleasantness, comfort, and aesthetic enjoyment, have been difficult to answer. Behavioral scientists have failed to obtain objective indicators of feelings and emotion, nor has the question been answered relating the environment and behavior. What degree of "cause and effect" can we expect between the two, and under what circumstances?

As the major consumer of viable building user information, the architect must play a key role in developing and refining it. To do this, they should be aware of the procedures used by researchers who develop information applicable to M/E problems. Architects should also understand better the behavioral research bases of building codes, standards, and regulations, which in turn depend on understanding how behavioral research studies are carried on.

Architects knowledgeable about behavioral research will be:

- More sensitive toward the advantages and limitations of behavioral research methods,
- Better able to identify possible limits of design data, more particularly as it applies to different types of activities and people within the building,
- Able to recognize better actual or potential user problems,
- Better able to critique criteria and building practices related to users,
- Able to make effective use of behavioral researchers as consultants or staff members,
- Prepared to ask better user-related questions of clients and building occupants,
- Better equipped to tap behavioral science source information directly.

## Measurement Techniques (After Lozar)

Self Report Methods	Man-Environment Interrelations and Dimensions
<b>Survey Attitude Instruments</b>	
Open-ended Question	General attitudes
Directed Question	General attitudes
Semantic Differential	Factors of perception
Correlation Mapping	Attitude and location
Cognitive Mapping	Attitude factors
Diaries-Activity Log	Time in daily activities
<b>Simulation Mechanisms</b>	
Photographic Simulation	Perception of drawings
Games	Choice under constraints
Scale Models	Perception of models
Video Simulation (experiential)	Perception of landscape
Video Simulation (interior)	Validity of TV simulation
<b>Interview Techniques</b>	
Unstructured	Perceptions
Structured	Attitudes
Participant Interview	Attitudes

**A Process Model for the Comprehension of Environmental Displays**  
(Craik)

1 Observers	2 Presentation of Environmental Displays	3 Nature and Format of Judgments	4 Validational Criteria
<b>Special Competence Groups:</b> <ul style="list-style-type: none"> <li>• Architects</li> <li>• Planners</li> <li>• Real Estate Appraisers</li> <li>• Stage Designers</li> <li>• "Space" Managers, (i.e., hotel, theatre, resort managers, building superintendents, etc.)</li> </ul>	<b>Direct Experience:</b> <ul style="list-style-type: none"> <li>• Looking at</li> <li>• Walking around and through</li> <li>• Driving around and through</li> <li>• Aerial Views</li> <li>• Living in</li> </ul>	<b>Free Descriptions</b>  <b>Adjective Checklists</b>  <b>Activity and Mood Checklists</b>  <b>Q-sort Descriptions</b>	<b>Measures of Objective Characteristics of Environmental Displays</b>
<b>Special User-Client Groups:</b> <ul style="list-style-type: none"> <li>• Elderly Persons</li> <li>• Migrant Workers</li> <li>• College Students</li> </ul>	<b>Simulative Exploration</b>	<b>Ratings</b>  <b>Thematic Potential Analysis</b>	<b>Judgments by Experts</b>
<b>Groups formed on the basis of Relevant Personality Measures</b>	<b>Cinematic and Photographic Studies</b>	<b>Symbolic Equivalentents</b>	<b>Any Judgment-form in Column 3 based upon more extensive Acquaintance with the Environmental Display</b>
<b>Everyman, General Public</b>	<b>Sketches and Drawings</b>	<b>Multisensory Equivalentents</b>	
	<b>Models and Replicas</b>	<b>Emphatic Interpretations:</b> <ul style="list-style-type: none"> <li>• "Role" enactments</li> <li>• "Role" improvisations</li> </ul>	
	<b>Tachistoscopic Views</b>	<b>Social Stereotypic Cues</b>	
	<b>Laser Beam Presentations</b>	<b>Beliefs about Human Consequences</b>	
	<b>No Presentation</b>	<b>Viewing Time</b>	
		<b>"Motivational" System</b>	



## Problem Areas

A major challenge facing M/E researchers is to find ways to quantify the benefits of improved building environments. For example, the benefits of quieter buildings are difficult to quantify so that such improvements are frequently placed in the category of unnecessary frills. Yet, long-term exposure to noise is thought to harm health and performance. If the effects of noise and other similar factors (e.g., air pollutants) are both bad and measurable, then not only costs but benefits associated with their control can be evaluated the same way as engineering decisions during the design process.

Architects' sources are mainly case study solutions organized as handbooks. The architect has the choice of using this information or calling in his own or outside resources to make the decision. Typical information sources used by the architect do not say why or under what circumstances a solution is appropriate (or inappropriate). For example, the architect might decide that walls for bedrooms should have a certain STC rating. Handbooks do not say why this rating was chosen or what was the research basis for the recommendation. Consequently, if the architect has to decide whether the rating fits a special-purpose facility (a home for the aged), he must look elsewhere.

Similarly, building codes and regulations exist in response to the health and safety requirements of occupants. Unfortunately, it is usually impossible to uncover the scientific or historical basis for code requirements, that is the rationale which supports them. For example, the width of exit stairways is often set for fire safety reasons. The dimension is chosen to let two people go down side-by-side, thereby speeding evacuation of a building. However, recent studies have shown that people move single file in a stairway. Other factors must also be considered, such as the need to provide room for stretchers, heavy equipment.

Design assumptions also merit attention. For example, HVAC systems of buildings are designed to provide a relatively constant temperature. Is this

a desirable goal? Perhaps variations of temperature or air movement within an acceptable range make more sense to the user.

Another hurdle concerns the different viewpoints of the architectural and behavioral research professionals even when exploring similar subjects. For example, both need to synthesize information on a variety of topics to develop a reasonable solution to a problem. Yet each does so with different types of payoff in mind. The process of synthesizing information is for the architect a means to the end of solving a problem related to the building being designed. In contrast, the researcher will often focus on the *process* of synthesizing information, so that the process will be better understood and used to solve similar problems in the future.

We have described these problem areas, and others throughout this study, not to undermine the credibility of the user-related information employed by architects. Rather, the aim has been to point out that much work is needed if improved user information is to become part of the design process of buildings. Fortunately, there is now some momentum. The performance approach, the rise of design teams, and the growing number of M/E studies all attest to progress.

Social scientists bring to these efforts a desire to better understand why people behave as they do, and they seek ways to document their findings. Architects, on the other hand, along with knowledge of the built environment, bring a trained and creative outlook to identify M/E problems requiring attention. Together, these professions should foster M/E research in whatever areas are deemed important by architects, users, and others, and which have until now been neglected by social scientists.



Architectural Handbooks (NBS)

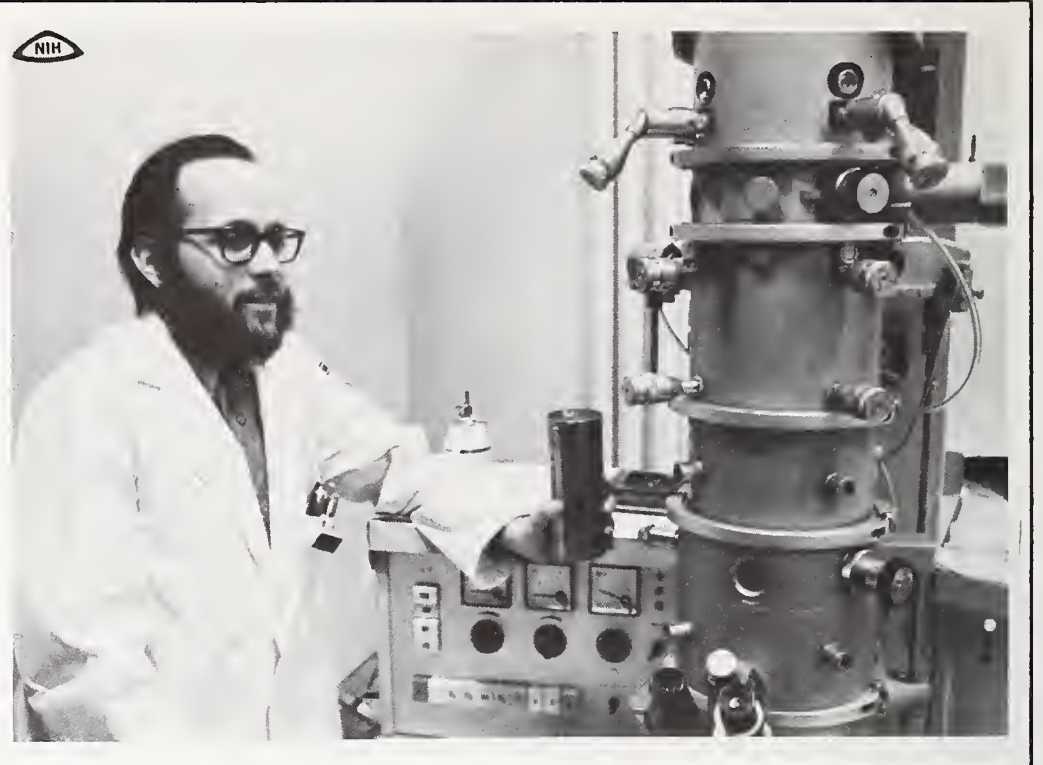



# Part VII

---

## Reference Material

While we have surveyed a broad range of disciplinary research areas and studied methods in the earlier parts of this work, we have at best merely touched the surface of the material available dealing with M/E issues. This concluding part of the study will provide an overview of three subjects which are essential to a balanced understanding of behavioral research as it applies to people and building relationships.

Chapter 19 describes the origins of behavioral research and reviews the traditions which influence how and why investigators today use the measurement methods that they do. It is meant to provide a perspective for present M/E studies.

Chapter 20 highlights the major research issues for studies using questionnaire survey methods. Since survey research may be used for most M/E problems, and is widely used, it merits separate and detailed treatment.

Chapter 21 provides a review of statistical procedures, which like survey research, comprise a broadly based disciplinary area providing the means for evaluating the outcomes of most scientific investigations and the development and improvement of M/E models.



Various Surgical Operations (Complete Encyclopedia of Illustrations—J. G. Heck, Park Lane, New York)

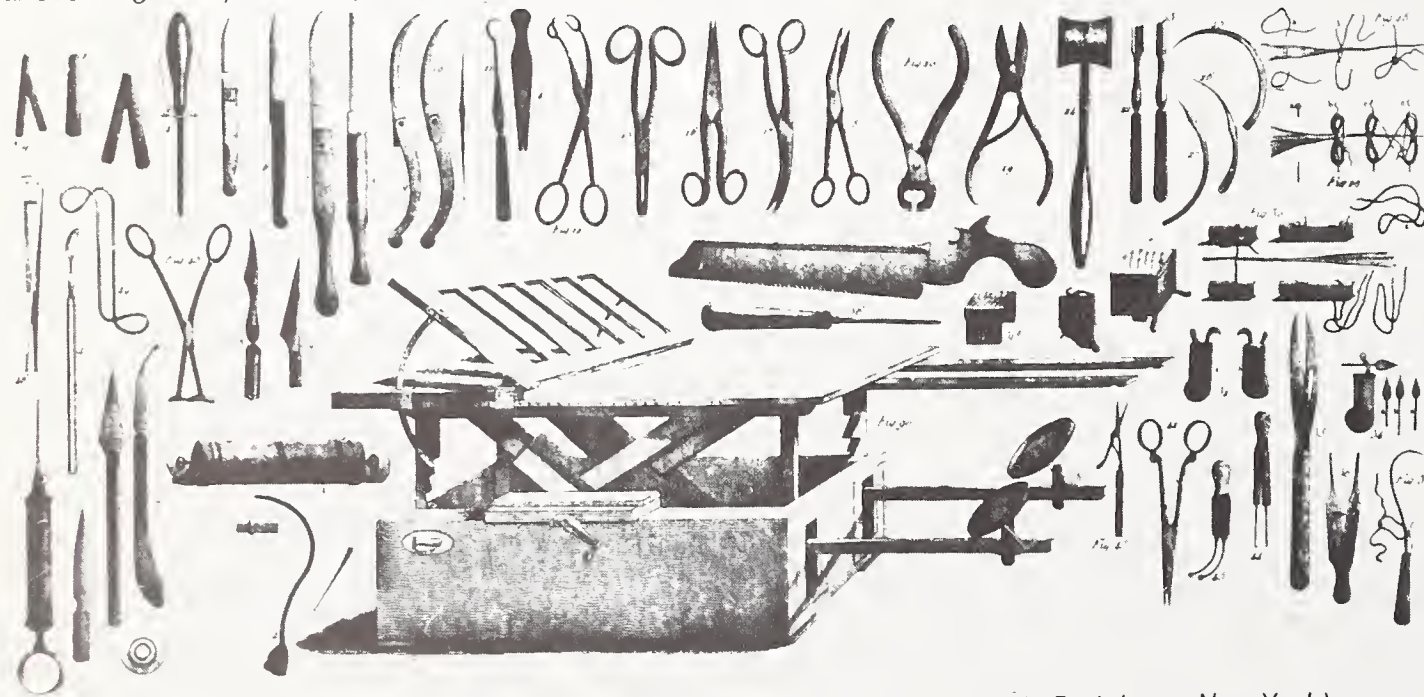

Various Surgical Instruments (Complete Encyclopedia of Illustrations—J. G. Heck, Park Lane, New York)



Early Illustrations and Views of American Architecture (E.V. Gillon, Jr., Dover Publications Inc., N.Y.)



## Behavioral Research— Historical Factors (Overview)

Diversity of Origins

Major Approaches

Analytic Research

Global (Gestalt)

Research Traditions—Philosophical

The Mind and the Body

Innate Characteristics

Learned Behavior

Research Traditions—Quantitative

Physiological

Early Studies

Central Nervous System

Reflex Behavior

Psychophysics

Experimental Research

Psychophysical Methods

Vision and Color

Color Specification

Visual Perception—Gestalt

Origins of the Gestalt Movement

Differences Among Individuals

Why People Act As They Do—Motivation and Personality Factors

Psychoanalytic Techniques

Projective Techniques

The Hawthorne Studies

Investigations of User Requirements

Conclusion

When people make judgments about their environments, whether favorable or unfavorable, what influences them? Why do people perceive the world as they do? What role does experience play in our lives?

The discipline of psychology has developed largely in response to answering these, and similar questions. The procedures employed to obtain answers to inquiries consist of a variety of measurement methods which are largely traceable to work performed in the 18th and 19th centuries. An understanding of the origin of these research procedures will provide an additional basis for evaluating their usefulness, and versatility, as well as their limitations for M/E studies.

The reasons for providing a cursory overview of the historical development of psychological measurement methods are therefore pragmatic, not academic. While it might interest some readers to learn even more about the origins of psychological research, we will confine our treatment to those men, issues, and methods which bear directly on the development of measurement techniques which are related to design.

The social sciences share a good deal with the profession of architecture. The problems dealt with are not always readily categorized, because they both seek to respond to the requirements and aspirations of people. Some needs are tangible and readily defined, such as those concerned with protection from dangers. In other

instances, needs have emotional and aesthetic connotations, which resist definition. People respond to environments at both conscious and subconscious levels of awareness. The social scientist and the designer must therefore not confine their interests to only those factors which can be readily identified, but must consider man "as a whole."

## Diversity of Origins

The study of psychological phenomena reflects the complexity of man. The approaches used have ranged from philosophical speculation to classical scientific procedures and finally the development of new techniques when traditional approaches were not successful.

A number of issues has dominated the discipline of psychology since its origin. They are of particular importance to M/E studies as well because of their relevance to design problems.

- How does man become aware of the environment?
- What are the relationships between thought and emotion?
- In what ways are individuals similar, and different?
- What commonalities exist among species, including man?
- What are the relative merits of the analytic, and global (comprehensive) approach to psychological research, i.e., how useful is the natural science model for psychological research?

## Major Approaches

When we examine historical developments in psychological research, two approaches appear to be dominant. One, the traditional one, is based on analytic procedures; while an alternative viewpoint is expressed by those who advocate a unitary approach which treats man as a complete entity.

### Analytic Research

The classical scientific approach is an analytic one. In its purest case, it consists of the control of all variables except the one being examined. That variable (independent) is then varied systematically by the researcher and measurements made on another variable (dependent). As one gains more information about the topic under investigation, a mathematical model of the phenomenon is developed to enable predictions to be made regarding the nature and extent of the influence of the independent variable on the dependent one. To accomplish this result, **quantitative** information is required.

The physiological research tradition has exemplified this classical research approach, and in doing so has been an early and important contributor to the discipline of psychology. Its objective is to find a biological basis to account for the way people respond to the environment, that is, to determine the extent of the relationship between the *structure* of the body and the way that it *functions*.

Closely associated with the classical physiological tradition in psychology

was the study of how the sensory processes of man operate.

**Psychophysics** was developed to determine the relationships between characteristics of physical stimuli (e.g., intensity of light) and the sensory perception by the individual (brightness). The goal was to obtain objective and quantitative information concerning sensory experiences by asking experimental subjects to function as pure measurement devices, untainted by subjective judgments and opinions.

### Global (Gestalt)

Classical research was challenged when problems arose which could not be attacked properly with the methods available. In both physiological and sensory (psychophysical) studies, innovative researchers challenged the applicability of research procedures, and simultaneously the assumptions associated with the research approaches. (The interdependence between research assumptions and experimental methodology is one of the primary reasons for presenting an historic overview of psychological research.)

In physiological research, it was Sigmund Freud (1856-1939), trained as a neurophysiologist, who found himself unable to explain behavioral symptoms for ailments such as hysteria on the basis of physiological findings. Consequently, he developed alternative methods of explaining behavior, which were qualitative and subjective, but which most importantly considered the patient's entire life experience.



One of the philosophical and research traditions of sensory research provides an alternative to the analytic study of behavior. This tradition, exemplified by the **phenomenologist** and **Gestalt** movements, has rejected the analytic approach as not being applicable to research dealing with behavior. Like Freud, the pioneer Gestalt scientists developed research procedures quite different from the traditional ones. They were qualitative rather than quantitative. They relied on demonstrations to make their points, something that everyone could experience.

The analytic and holistic approaches were not parallel developments. Rather, they were often closely interrelated, exercising considerable influence on one another. When either the analytic or Gestalt approach predominated, advocates of the other approach were actively developing alternative approaches. For example, the Gestalt emphasis on an integrated approach based on immediate and naive perceptions was a reaction to the analytic procedures developed by psychophysicists to understand the elements of sensation and perception.

Since current behavioral research is traceable to traditions in both philosophy and science, it is not surprising that its methodologies have antecedents in both "camps." Furthermore, the advantages and disadvantages of many research methodologies are traceable to these origins. A number of the traditions which form the basis of psychological research today will now be examined.

## Research Traditions— Philosophical

How does the inner world of man interact with the outside world? That is, how do people gain knowledge of the world at large? There are two major opposing viewpoints designed to answer this question. One stresses the importance of the inborn characteristics of people—termed a *nativistic* outlook. The advocates of this approach argue that people are basically preprogrammed in a way that ensures their ability to live effectively in the world. The opposing viewpoint emphasizes the adaptability of people and argues that people are born with the *potential* for learning, and life experiences provide the learning necessary for survival and accomplishment.

This issue was the cause for speculation by philosophers as far back as the earliest writings by the Greeks.

### The Mind and the Body

In more recent times, Rene Descartes (French philosopher, 1596-1650) is often mentioned as the one who identified many issues which later became central to the discipline of psychology. Descartes was concerned with the relationship of the mind and the body which the Greek philosophers speculated about. He hypothesized that the mind and body of man interacted at the pineal gland, which is at the base of the brain (cerebrum).

Descartes was important for another reason. He was part of a philosophical tradition but at the same time relied on the *empirical* approach used by scientists. (In an effort to learn how the nervous system operated, he dissected parts of the body which were then observed in detail.)

### Innate Characteristics

Gottfried Wilhelm von Leibnitz (German philosopher, 1646-1716) indicated that the human body was born with a system of complex and interrelated elements called *monads*. Monads were defined as fundamental activities which became evident while the person matured. In a sense, the monad can be termed as a perceptual element, not capable of further analysis. The work of Leibnitz therefore addressed two problems of vital interest to psychological research—the importance of innate characteristics and the limitations of the traditional analytic approach to research.

Immanuel Kant (German philosopher, 1724-1804), speculated that the human "mind" is predisposed to think and perceive in certain ways. For example, spatial relationships are perceived as they are because perceptual ordering is a psychological necessity. This viewpoint has been elaborated by later researchers, thereby constituting a major alternative to the analytic procedures favored by researchers following classical scientific procedures. The rationale for

phenomenological, Gestalt, and many present-day perceptual researchers can be traced to the work of Kant.

Rudolph Herman Lotze (German philosopher, 1817-1881), a more immediate and direct influence on the Gestalt movement, had a theory of space perception. He indicated that the mind has an inherent capacity for arranging sensory content spatially, even though that content is not inherently spatial. Another way of making this point is that perceived space is derived from conscious data, themselves not spatial.

This cursory treatment of the philosophical origins of the **nativistic** approach will now be followed by a similar treatment of a number of the philosophical advocates of the learning approach in psychology who also served as theorists for analytic research in psychology.

### Learned Behavior

Thomas Hobbes (English philosopher, 1588-1679) disagreed with Descartes concerning how man comes by his ideas. He argued that **sensations** are the ultimate source of knowledge and that people learned to associate sense impressions with one another. The associations were said to be formed when two conditions come together either in space or time and the associations strengthened when the conditions are repeated. For example, when we say "grass," we think of the color green because we repeatedly experience the visual sensations together. This concept may be considered as a conceptual forerunner of the analytic approach to psychological research.



John Locke (English philosopher, 1632-1704) carried the position of Hobbes to the extreme in his view that the infant's mind is a "tabula rasa" (blank tablet) and therefore all knowledge is gained from experience. Ideas are the elements of experience, which an analysis of the mind will reveal, that is, the mind can be analyzed in terms of elements called ideas.

James Mill (English philosopher, 1773-1836) argued that sensations and ideas are the raw material of the mind. Knowledge is said to begin with sensations, which are then transformed into larger units which are capable of being analyzed into elements. For example, Mill says *brick is a complex idea, mortar another complex idea, these ideas together with ideas of position and quantity, compose my idea of a wall.*<sup>1</sup>

John Stuart Mill (English philosopher, 1806-1873) disagreed with the foregoing conception by his father, James Mill. He argued that many elements may *generate* complex ideas, but these ideas are more than the mere sum of the individual parts. For example, if we add blue and yellow pigments we obtain a green pigment which would not be predicted from each of the constituent elements. Mill stressed the need for direct experimentation, instead of speculation, as the way to learn about the characteristics of man, thereby promoting scientific inquiry of human behavior.

With the ideas of John Stuart Mill, we will now examine the *research* traditions in psychology.

## Research Traditions— Quantitative

### Physiological

Man's biological inheritance plays an important role in determining behavior, although the extent of this role is sometimes a topic of dispute. For example, there are inherent limitations in our ability to sense environmental stimuli. That is, there are many sources of potential stimulation in the environment, such as different forms of energy. People have the ability to detect some forms of energy (e.g., sound, visible light) but not others (e.g., x-rays, ultraviolet rays). Even when we have the sense organs to detect energy we are limited in our ability to use it effectively. If a sound is too soft, or at too high or low a frequency, it cannot be heard; if a sound is too intense, it can cause permanent hearing damage.

Of particular importance is the lack of a clear relationship between our ability to detect things in our environment and their effect on us—for good or ill. Atmospheric pollutants, ultraviolet rays, and odorless gases all have the potential to affect our well-being, but the effects frequently are not noticeable until the damage is done.

<sup>1</sup> E. Boring, *A History of Experimental Psychology* (New York, 1950).

When people are affected by such environmental factors, how may we determine the nature of such effects? We cannot rely on observations by researchers using the unaided eye—the effects are not always readily visible. We cannot ask people to examine their own reactions, because as we already have indicated some effects cannot be sensed.

For problems of this type, more subtle and sensitive detectors of short- and long-term changes that might occur within people as a result of environmental conditions are needed. These procedures are equally applicable when the changes are internal to the person, e.g., emotional. The observation and measurement of these phenomena have been the province of physiological research in psychology. In a sense, physiological investigators treat experimental subjects as though they were "black boxes," ignoring subjective aspects of behavior. Their goal is to make measurements which are biologically determined rather than being under the conscious control of subjects. Advocates of physiological studies of behavior indicate that physiological responses have the advantage of being relatively free from "extraneous" influences such as experience, preferences, and cultural factors, which unduly complicate research in the behavioral sciences.

Many important M/E studies are physiological in nature, especially those dealing with stimuli which are likely to cause permanent damage.

One such example is research performed to determine the effects of smoke resulting from fires in buildings on health, well-being, and behavior. Studies of this kind are frequently conducted using animal subjects. The research procedures employed often include the destruction of the animal, followed by an autopsy to determine the effects of various compositions and intensities of smoke on the organism. Similar procedures have been used in noise studies to pinpoint the site of the damage caused by intense sound levels.

The disciplines of physiology and neurophysiology have particularly benefitted by space-age technologies which have revolutionized research procedures leading to an abundance of information concerning the human body, such as detailed photographs and measurements of body structures.

The newly developed physiological procedures enable M/E studies to be performed which were not feasible until now. For example, *eye marker cameras* enable us to determine environmental features observed by experimental subjects, e.g., how many times and for how long an object was viewed by a person. *Thermographic cameras* enable us to determine the temperature of various parts of the body to provide insights into temperature and the feeling of thermal comfort. Physiological recording devices are employed to determine the effects of different types of activities on such factors as heart rate, respiration, and blood volume.



The sophisticated and frequently electronically based physiological research methods of today, such as electron microscopy, are an outgrowth of the techniques which can be traced back to the 18th century. Then, as is the case today for many researchers in the human sciences, a biologically based explanation for observed behavior was the goal.

### Early Studies

The desire to learn more about the interaction of man and environment in the 18th century was not confined to philosophical speculations.

Physiologists were actively engaged in research designed to better understand the functioning of the brain, the nervous system, and the sensory modalities and how these structures interacted with one another. The methods available to early researchers were quite primitive, but the problems addressed were often similar. The studies were particularly concerned with explaining the relationship of sensory, neural and motor functions, behaviors explained by the biological characteristics of man.

Physiological research in psychology (perhaps more than any other behavioral research area) was in the mainstream of traditional research. The experimental procedures employed evolved directly from other related disciplines (e.g., biology). Only a few of the early researchers will be mentioned to illustrate the particular problems addressed and the types of methods employed.

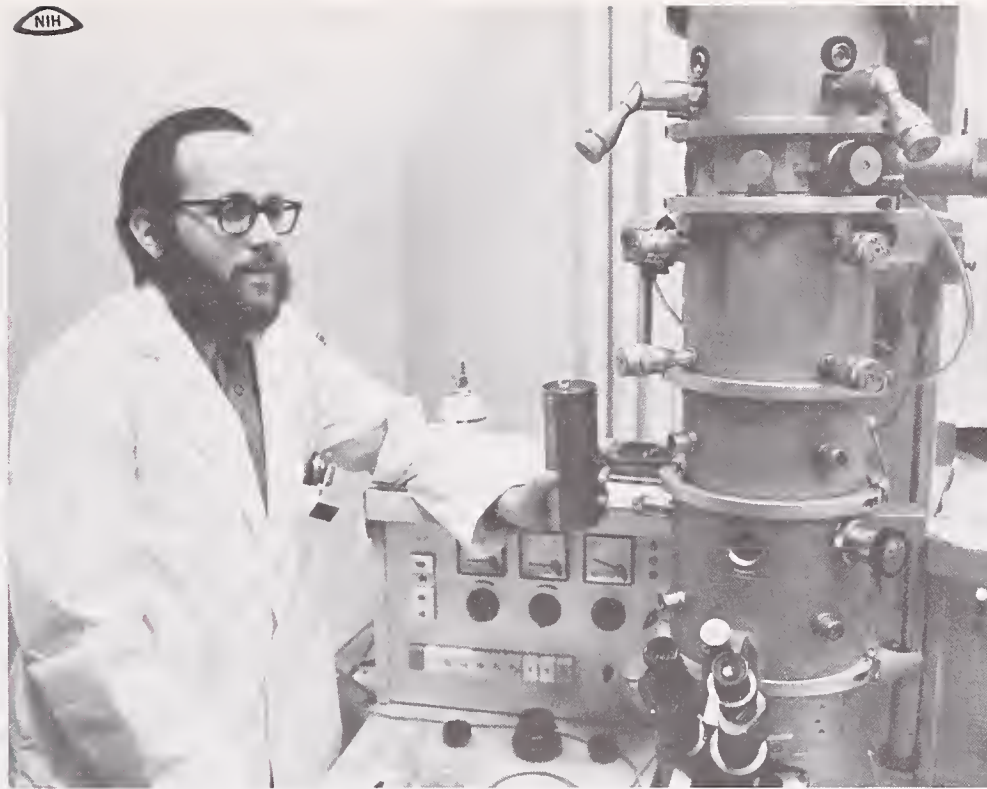

*Electron Microscope (NIH)*

### Central Nervous System

Marshall Hall (English physiologist and physician, 1790-1857) is often listed as the forerunner of physiological psychology. He observed animals after decapitation and noticed that *movements* continued when appropriate stimulation was provided. He concluded that there were several layers of behavior: Voluntary—brain (cerebrum); reflex—spinal cord; involuntary—muscles; respiratory—brain (medulla).

Pierre Fluorens (French researcher and philosopher, 1794-1870) followed the work of Hall and concentrated on

the functions of the brain, which was considered a relatively simple organ. He employed careful experimental procedures which consisted of removing (extirpating) areas of the brains of animals to determine the effects on behavior. He removed one major area at a time, on the assumption that each part had separate and independent functions. He found that brain structures were closely related to particular sensory and motor functions.

G. Fritsch (German anatomist, anthropologist, 1838-1927) and I. Hitzig (German physiologist, neurologist, 1838-1907) used electrical stimulation

of the cerebral cortex of a dog as an independent variable to identify the motor areas within the brain, with movements of the body and limbs being the dependent variables. Their work led to follow-up studies by others which resulted in the detailed mapping of the motor centers of a variety of animals.

Charles Bell (English physiologist, 1774-1842) and Francois Magendie (French physiologist, 1783-1855) employed experimental animals whose nerves were systematically severed to determine the effects of this procedure on motor movement. They found that sensory and motor nerves are both anatomically and functionally separate from one another in the spinal cord.

Paul Broca (French pathologist and anthropologist, 1824-1880) is often identified as the originator of the clinical (symptomatic) study of brain functioning. He was a physician who treated a patient for many years who appeared to be normal in all respects except that he could not speak. After the patient died, an autopsy was performed and Broca found a brain lesion (in the third frontal convolution of the left cerebral hemisphere) which was the cause of the speech impairment. This was the first clear-cut demonstration of the localization of function within the brain.

We will conclude the historical background of physiological research methods by mentioning two Russian investigators identified with the study of reflex behavior.



## Reflex Behavior

M. Sechenov (Russian physiologist, 1829-1905) demonstrated that when salt was placed on the cut end of the spinal cord, that spinal reflexes were inhibited. He also identified an inhibitory center in the brain. Sechenov argued that all thinking and intelligence depend on stimulation and that all acts of conscious and unconscious life are reflexes.

Ivan Pavlov (Russian physiologist, 1849-1936) was influenced by the earlier work of Sechenov in his studies of reflexes. Pavlov operated to bring the ducts for the digestive secretions to the surface of the body, so that secretion could be easily observed and measured. By this means then he discovered how the digestive juices begin to flow when animals anticipate food. Out of that observation grew the technique of the conditioned reflex, the measuring of anticipation by observing the flow of gastric and intestinal juices or saliva. Pavlov saw that he had a means for measuring many qualities earlier regarded as psychical. At first he spoke of "psychical secretion"; later he would write "the so-called psychical processes"; still later his phrase was "conditioned reflexes."

Every student of psychology now knows the nature of "classical conditioning," in which a second stimulus, which occurs with or just before the stimulus of an unconditioned reflex, comes, with repetition, to elicit the reflex movement alone.

*Conditioning is an objective substitute for introspection, a form of language which enables an experimenter to know what discrimination an animal can make, what it does and does not perceive. Conditioning is, in fact, a kind of language, which the experimenter provides so as to enable an animal to communicate with him, but the phenomena of communication occur entirely on the objective level of stimuli, nerve-action and secretion, without any need for assuming consciousness as an entity. Nevertheless, because we are so accustomed to use the vocabulary of consciousness, the old psychical terms inevitably creep into common thought about these matters, as they did also in Pavlov's exposition.<sup>2</sup>*

## Psychophysics

The architect, in order to meet the needs of those who are to occupy the buildings being designed, manipulates physical characteristics of the environment. A major assumption shared by architects and psychologists is that the environment does have an influence on behavior, although the magnitude of the relationship is often disputed. Behavioral research, if it is to be useful to the architect must therefore say something about the relationships of the physical environment and behavior. The study of psychophysics was founded to explore and quantify

these relationships. Such studies share a characteristic with physiological investigations, the premise being that man should be studied from a biological standpoint having inherent capabilities and limitations, traceable to bodily structures and functions.

Psychophysical studies have been traditionally designed to relate sensory processes (seeing, hearing) to environmental stimuli. Their goal was to determine the nature and intensity of a stimulus (S) which results in responses (R) by subjects which take such forms as:

- I can barely smell anything.
- The first sound is louder than the second one.
- The buildings are of equal height.
- The light on the left is just noticeably brighter than the one on the right.

Experimental subjects therefore respond as though they were measuring instruments (experience and training theoretically being of secondary importance).

Psychophysical investigations, which today are conducted by many laboratory researchers, can be traced to the origins of psychology, when the basic approaches were developed.

## Pavlov's Conditioning Apparatus

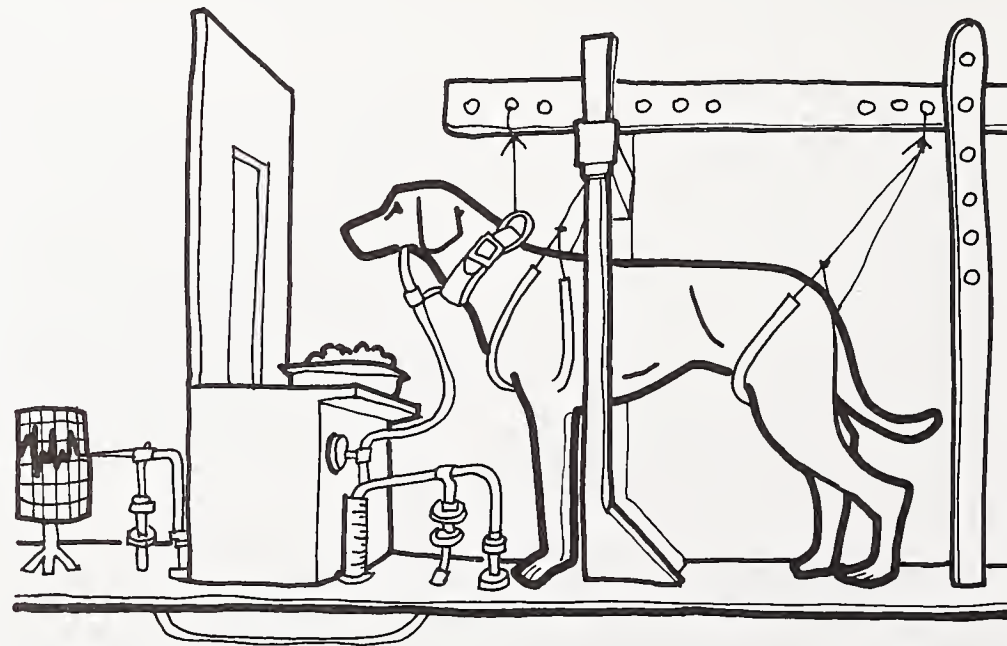

<sup>2</sup> Boring



## Experimental Research

Wilhelm Wundt (German physiologist and psychologist, 1832-1920) is considered the founder of experimental psychology because he was the first person who promoted the idea of psychology as an independent science. Wundt, in his laboratory at Leipzig, Germany, undertook a program of research which was a logical extension of the philosophy of James and John Stuart Mill. *Wundt outlined the problem of psychology as (1) the analysis of conscious processes into elements, (2) the determination of the manner of connection of these elements, and (3) the determination of their laws of connection. The goal of psychology is the analysis of mind into simple qualities and the determination of the form of their ordered multiplicity. The method, Wundt thought, is adequate to the problem except in the case of the higher processes, where analysis fails and we are reduced to the comparative observation of social phenomena.*<sup>3</sup>

The laboratory work at Leipzig explored the areas of sensation and perception, with special emphasis on vision. The visual studies covered a broad range of topics including color, form, and size perception, optical illusions, binocular vision, and perceived movement. These topics are not substantially different from those now being pursued by visual researchers, although the methods used by current investigators are not limited to those employed by Wundt and his associates.

<sup>3</sup> Boring

## Psychophysical Methods

The experimental method employed by Wundt was a psychophysical one, developed with two other Germans, Ernst Weber (German physiologist and anatomist, 1795-1878) and G. T. Fechner (physicist and philosopher, 1801-1887).

Weber was especially concerned with how the subjective world of an individual relates to the physical world—the body as well as all physical surrounds which are capable of being perceived. Unlike Descartes, Weber employed an empirical approach to collect information. He systematically varied a series of weights to study the ability of human subjects to make judgments about the weights. Subjects were asked to determine when it was possible for them to make consistent judgments as to whether two weights were similar or different. He developed a scale based on the ability of subjects to make just noticeable discrimination (JND's) of compared weights. He later used the same technique to study "brightness" discriminations.

The need to connect the inner world of sensation of the individual to the outer world of physical objects and energy in its many forms (radiant, acoustic, etc.) was highlighted by Fechner, who is often considered the founder of psychophysics. Fechner pointed out that if sensory experiences are to be understood, we must be able to make statements about the relative size of sensations, for example, that one light was two or three times as bright as another one.

The desire to quantify such sensations dates back to Hipparchus in ancient Greece (approximately 150 B.C.), who invented a scale of stellar magnitude. The brightest stars of the "first magnitude" and those which appeared less bright were assigned different magnitudes. A sixth magnitude star was one which could barely be seen. (Stellar magnitudes are still used today as a form of classification.)

Fechner began with the work of Weber and extended his research into other sensory areas. Fechner argued that *sensation* could not be measured (this assertion is not generally agreed to any longer). All we can do, he agreed, is to observe whether a sensation is present or absent, or that one sensation is greater than, equal to, or less than another sensation. We are unable to say anything about the absolute magnitude of the sensation, but we can measure stimuli, and therefore measure the stimulus values necessary to give rise to a particular sensation (or to a difference between two sensations). We can therefore measure the threshold values of the stimulus which correspond to sensitivity measurements (sensitivity being the inverse of the threshold value). Fechner distinguished between *absolute* and *differential* sensitivity (the latter referring to the minimal separation required between two stimuli, along a relevant physical scale, in order for them to be judged as different). He recognized the importance of making many measurements because judgments vary and he

## Photometric Intensity of Stars (based on thousands of historical observations)

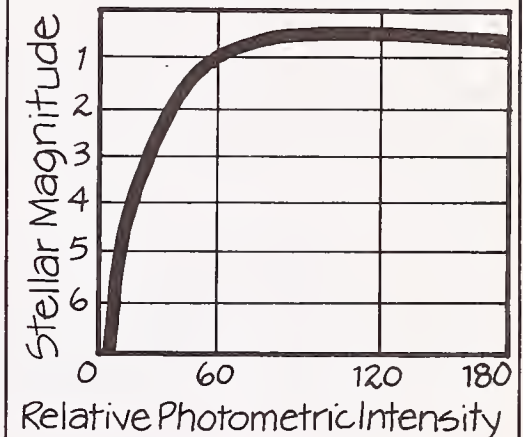

therefore employed statistical techniques to analyze his data.

Since Fechner believed that sensation could not be measured directly (while the stimulus could), he had to formulate a procedure to indirectly measure sensation. He employed increments of **just noticeable differences (JND's)** to determine the magnitude of sensation—one JND being the basic measurement unit. The validity of the procedure, which assumes that the JND's are equal to one another regardless of the level of the stimulus, is not generally accepted today. However, experimental findings have generally supported this approach when judgments are made at moderate intensity levels.

Perhaps Fechner's most significant contribution to research is the three basic methods he developed to collect psychophysical data.



- **Method of average error**—This approach starts with the assumption that it is not possible to obtain a single true measure of anything because sense organs and instruments vary. We therefore have to obtain a large number of approximately equal measurements and obtain a distribution of values. The average (mean) of this distribution is the best available approximation possible of the “true value.” Since each individual judgment is considered an error (a departure from the true value), it was named the “method of average error.” An example of the use of this method is to present a pair of lights to a subject, varying in intensity. The task of the experimental subject is to adjust one of the lights until it appears just as bright as the comparison light. A number of different judgments is required, each one representing a single trial. The average of the trials then is computed to determine the best estimate of the “true” value. That is, a number based on many judgments is likely to be more correct than one derived from few judgments.

- **Method of constant stimuli**—The experimenter preselects a number of levels of the variable that he is studying. For example, if he is concerned with the ability to judge length, and selects lengths of 10, 20, 30, 40, and 50 millimeters (mm), for each of the preselected lengths he develops “comparison” lengths ranging from 1 to 3 mm above and below the standard (constant) one. The subject is then required to judge the comparison lengths against the standard one (are they longer or not, shorter or not?). The judgments are made for a

number of trials presented in a random order, each judgment being made several times. After all of the judgments are made, they are analyzed statistically to determine when a preselected criterion has been met (e.g., What length is seen as longer than the standard on 75% of all trials?).

- **Method of limits**—This method is more specialized than the preceding ones and is primarily used to determine thresholds of sensitivity (when a stimulus can barely be perceived). For example, if we want to determine the range of frequencies which can be heard we may start at 100 Hz and present tones at higher and higher frequencies keeping intensity constant until the subject can no longer hear anything. The *limit* is the highest frequency heard. Ordinarily, we would also start at inaudibly high frequencies and progressively lower the frequency until the tone can just be heard. The threshold is usually the computed average of the two limits, which typically differ somewhat. A similar procedure can be used to determine the low frequency limit as well as the low intensity limit for a variety of frequencies.

It is difficult to exaggerate the importance of these methods in the evolution of an experimental approach in psychology. A considerable proportion of the research findings available are based upon this work, especially those investigations concerned with specifying characteristics of the sensory environment in buildings, such as lighting levels, acoustical criteria.

Fechner assumed that people were not capable of making direct estimates of magnitudes, e.g., one sound being three times as loud as another. Instead, he employed the concept of just noticeable differences (JND) which were defined as “equal units of sensation.” The sound would be increased until a subject reported a JND, which was the second step in the ladder. The second sound is then increased until another JND is identified. A sensation of a given loudness is then defined as the sum of all of the JND steps. Physical measurements are made of the sound levels at each step. The *psychophysical* data obtained therefore include physical measures of the stimulus (e.g., sound) and corresponding sensations. Generally, such investigations have shown that the physical size of the JND grows larger in direct proportion to the magnitude of the stimulus.

### Fechner's Law

(Stimulus increases geometrically, sensation increases arithmetically)

sensation (arithmetic)

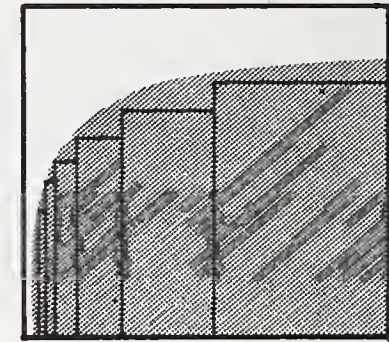

stimulus (geometric)



Laboratory Psychoacoustic Research (NBS)



In devising sensory scales, Stevens, in contrast to Fechner, often had subjects make direct estimates of the magnitudes of sensations. A sample of the instructions given to participants in scaling investigations by Stevens was as follows:

*You will be presented with a series of stimuli in irregular order. Your task is to tell how intense they seem by assigning numbers to them. Call the first stimulus any number that seems appropriate to you. Then assign numbers to successive impressions. There is no limit to the range of numbers that you may use. You may use whole numbers, decimals, or fractions. Try to make each number match the intensity as you perceive it.*<sup>4</sup>

Stevens then carried his procedure one step further than most psychophysical researchers. He had subjects respond to one sensory stimulus (e.g., sound) by modifying the intensity of another stimulus (e.g., light) until they were equally matched in subjective intensity. For example, in one such study, subjects were asked to adjust the level of a white noise until it matched the brightness of a light. In this way, Stevens developed a body of information which related the responses made to sensory stimuli to one another (e.g., odor, vibration). He used the same technique to obtain measurements of other factors (e.g., judgments of length).

### Equal Sensation Functions (Stevens)

Equal Sensation Functions obtained by matches between loudness and various criterion stimulus

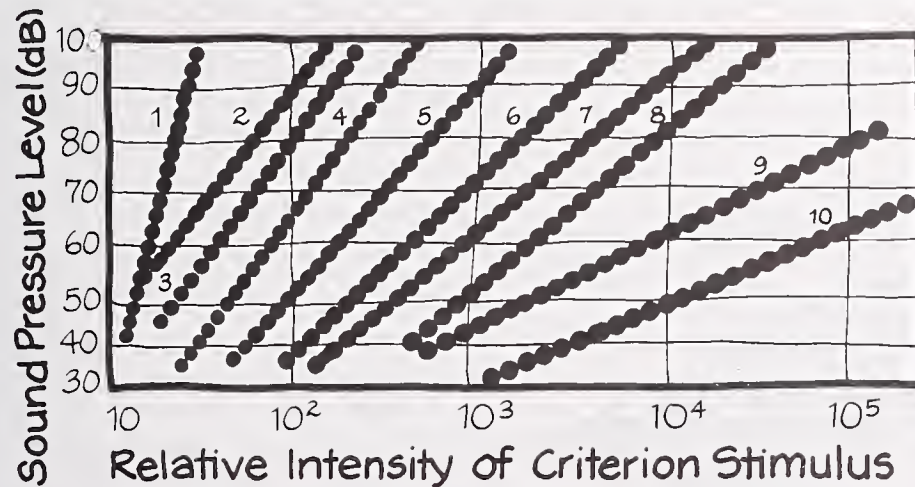

- 1 elec. current (60Hz)
- 2 handgrip
- 3 redness
- 4 roughness
- 5 vocal effort

- 6 vibration (60 Hz)
- 7 number
- 8 length
- 9 brightness
- 10 hardness

### Vislon and Color

The systematic study of color dates from the experiments of Isaac Newton (English physicist, 1642-1727). His critical discovery was that the refraction of white light by a prism breaks it up into the different spectral colors which can be differentiated from one another by the degree of refraction associated with each one. In order to determine the number of separate colors he performed a study with himself and his assistant serving as subjects. Boring quotes Newton as follows: *I delineated therefore in a Paper the Perimeter of the Spectrum and I held the Paper so that the Spectrum might fare upon this delineated Figure, and agree with it exactly, whilst an Assistant, whose Eyes for distinguishing Colours were more critical than mine, did by right lines drawn cross the Spectrum, note the Confines of the Colours . . . And this Operation being divers times repeated both in the same, and in several Papers, I found that the Observations agreed well enough with one another.*<sup>5</sup>

As a result of this study, Newton concluded that there were seven pure colors, corresponding to seven kinds of light.<sup>6</sup>

Newton's investigations were not limited to the analysis of light into spectral components but also included laws of color mixture of light sources:

(I) Colours may be produced by Composition which shall be like to the Colours of homogeneal Light as to the Appearance of Colour, but not as to the Immutability of Colour and Constitution of Light. And those Colours by how much they are more compounded by so much are they less full and intense, and by too much Composition they may be diluted and weaken'd till they cease, and the Mixture becomes white or grey. There may be also Colours produced by Composition, which are not fully like any of the Colours of homogeneal Light.

(II) Whiteness and all grey Colours between white and black may be compounded of Colours, and the whiteness of the Suns Light is compounded of all the primary Colours mix'd in a due Proportion.<sup>7</sup>

### Newton's Color Circle

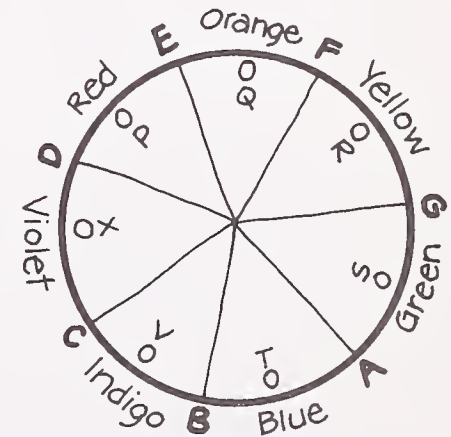

<sup>4</sup> S. S. Stevens, *Psychophysics* (New York, 1975).

<sup>5</sup> Boring

<sup>6</sup> Boring

<sup>7</sup> Boring



Boring indicated that:

*The greater number of experiments supporting these laws was made with the optical system in the accompanying illustration. By allowing only certain colors to pass at L, the resultant mixture can be seen by placing a screen at W2. Newton found that, with proper combinations of lights, fewer than all the primaries can produce white. He found too that, the more complex the mixture, the lesser the saturation of the color. The rapid succession of colors, he showed, produces the same result as their simultaneous mixture. This last discovery he made by fashioning a cardboard comb with teeth as wide as the spaces between them and moving the comb rapidly up and down at the lens, L. In this case some of the colors were always intercepted at any moment but the rapid succession gave white at W2 His reference to mixed colors, "which are not fully like any of the Colours of homogeneous Light," was, of course, to the purple.<sup>8</sup>*

Newton also experimented with surface colors and concluded that the colors of objects are due to their selective reflection of light. Newton thereby discovered and established the essential directions for color research for all of those who studied this topic after his time.

Thomas Young (British physician and philosopher, 1773-1829) discovered that the experimental findings obtained by Newton could be explained on the basis of three primary colors. As a result, he thought of the color figure as a triangle, instead of a circle

since all color mixtures will lie within the triangle formed by them.

Herman von Helmholtz (German physiologist, 1821-1894) tried to establish a physiological basis of color theory based on the speculations of Young. He investigated color mixture phenomena in paints as well as lights and noted the differences in the phenomena. He then modified the laws of color mixture formulated by Newton indicating that they hold for lights but not for pigments.

Although there were at that time three principal methods of mixing colors, the one advocated by Helmholtz consisted of mixing pure spectral lights. An optical system with a prism, similar to the one shown for Newton, was so arranged that most of the colors could be interrupted, the

### Color Theory (Young-Helmholtz)

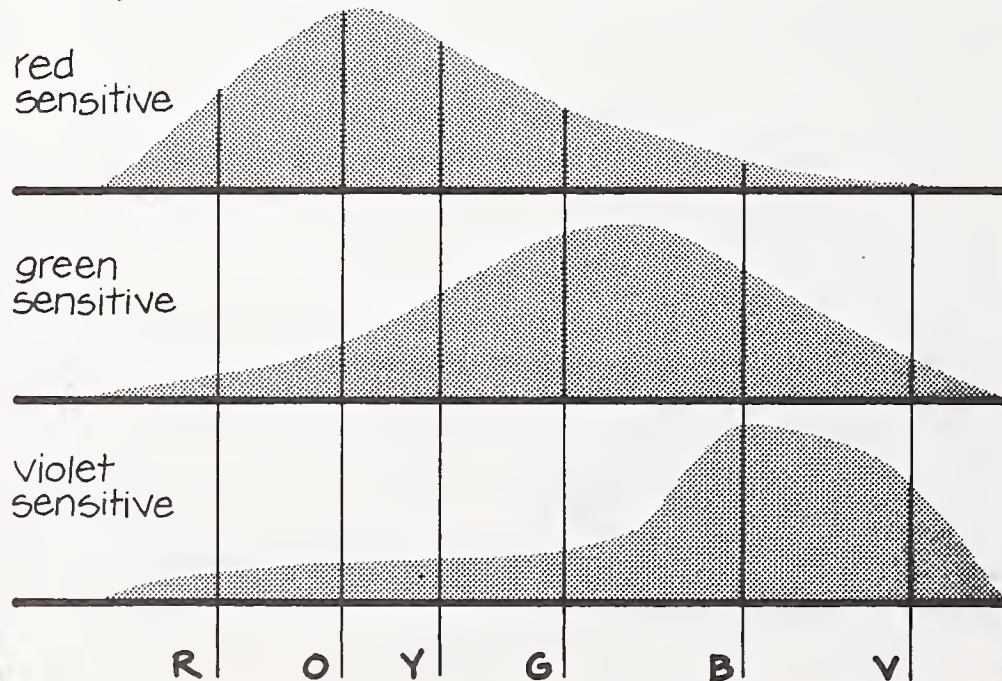

### Helmholtz's Color Triangle

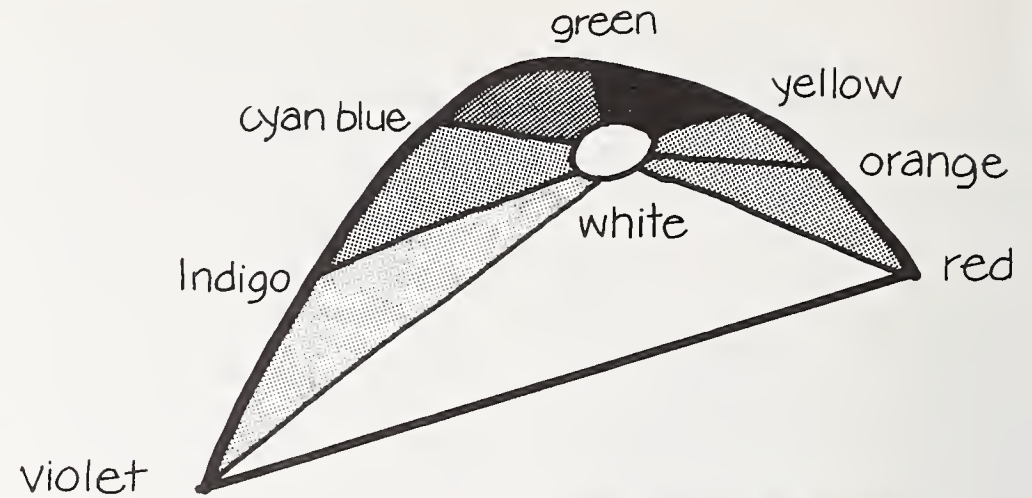

chosen colors be left, allowed to recombine, and viewed projected upon a screen or through a telescope. This procedure was used to examine pairs of lights of differing colors which when combined in appropriate ratios give the sensation of white. Innumerable pairs of such combinations are possible. (Helmholtz did not limit his studies to visual phenomena; he was equally active in the area of psychoacoustics.)

Boring describes the other two methods known at the time of Helmholtz in the following way:

*There was also the method of mixture by transmission and reflection, a method originated by J. H. Lambert in 1760. The observer, viewing one color obliquely through a glass plate, sees another color reflected from the glass, the two superposed. Helmholtz, when he described the method, pointed out that it could be used with colors obtained by white light passed through liquid filters. This technique is common today with plate glass or half-silvered*

<sup>8</sup> Boring



mirrors in a wide variety of situations which require the combination of two visual fields. The half mirror is set at 45° to the line of sight, so that one field can be seen directly through it and the other, at right angles to the line of sight, as reflected from it.

Of course the simplest method of mixture is the combination of colors as sectors of a disk which rotates so rapidly that the colors fuse. Maxwell (1855) invented the colored disks with the radii cut so that the disks can be fitted together and the resultant sectors varied at will.<sup>9</sup>

Arthur König (German physicist, 1856-1901) prepared the way for follow-on work in color in much the same way that Newton had done earlier. König determined the brightness and sensitivity response of the eye as a joint function of wavelength and intensity, using a method similar to that of Helmholtz. He performed a study, with himself as the only subject, using 13 different wavelengths, at 8 levels of intensity ranging from absolute threshold (barely detectable) to a high level of intensity. The curves he obtained were interpreted as demonstrating two kinds of sensitivity curves (and underlying sensory receptors), one for daylight (cones) vision and the other for nighttime (rods) viewing. These data (together with those of one other investigator, Abney) formed the primary basis for international color specification until 1931. (Like Helmholtz, König explored auditory phenomena as well as visual ones.)

<sup>9</sup> Boring

## Color Specification

In 1931, the International Commission on Illumination (formerly ICI, now CIE) wanted to systematize the specification of colors and base it on a physical measurement system using three primary colors. W. Wright summarized this approach as follows:

*Before a system of colour measurement can be established, agreement on two separate issues is required. The distribution coefficients give the amounts of three stimuli required to match the colours through the spectrum and the first stage in the preparation of a standard system of colour measurement is therefore the adoption of colour-mixture data representative of a normal observer. The second stage required agreement on a set of reference stimuli relative to which the distribution coefficients can be transformed and in terms of which standard colour specifications can be expressed. This second issue can be decided from considerations of practical convenience in technical work without the limitations that are imposed on the choice of stimuli in a visual colorimeter.*

## König's Color Triangle

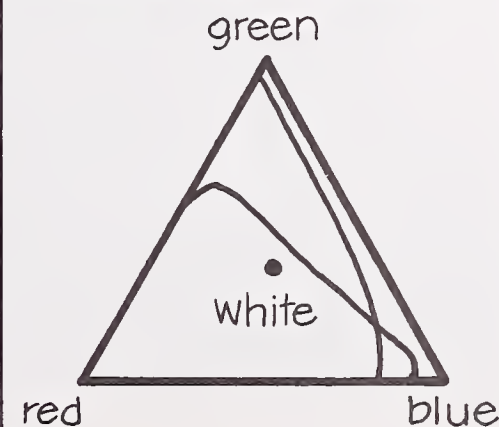

*The essential observations that had to be made were a series of colour matches of the spectral colours by means of some form of trichromatic colorimeter. The light received by the observer consists of a series of rapid pulses of red, green, and blue radiation, which, owing to the persistence of vision, are perceived as a steady beam of a uniform colour whose chromaticity and luminance are governed by the openings in front of the three filters in AB. These openings are controlled by radial shutters T1/, T2/ and T3/, which are adjusted by the observer until the mixed beam matches the test colour; the angular setting of the shutters then gives a measure of (R), (G) and (B) in the mixture.*

*The spectral colour to be matched was provided by an independent double-monochromator light of wavelength  $\lambda$  emerging from the exit-slit which was projected into the other half of the photometer prism.<sup>10</sup>*

Wright conducted a study parallel to the one designed by Guild. This study employed similar though not identical apparatus and the same experimental procedure. The data obtained from these two investigations were averaged with those mentioned earlier (König and Abney) to define the CIE 1931 Standard Observer. Once the color matching characteristics of the standard observer were defined, it was necessary to agree on reference stimuli; the RGB (red, green, blue) system was not adopted because negative quantities would be necessary and this would pose difficulties in terms of computations and "hardware" development, e.g., colorimeters.

The distribution curves form the basis of the CIE system; they confirm all of the data needed to specify colors. (The 1931 Standard Observer data have since been corrected and modified but stand as *The* international standard for color specification.)

## Example of CIE Chromaticity Boundaries

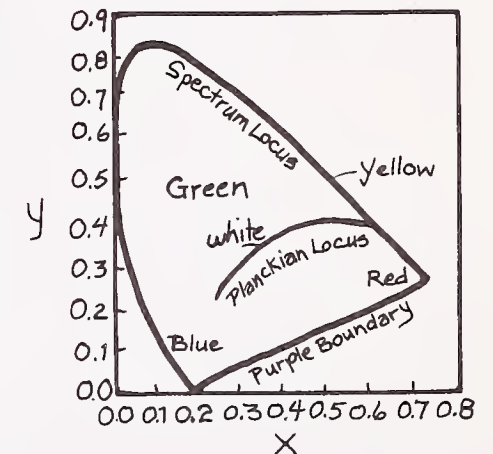

<sup>10</sup> W. D. Wright, *The Measurement of Color* (London, 1958).

We noted earlier that the scientific (analytic) study of behavior had its counterpart among those who favored a holistic and phenomenological approach. This dichotomy existed in color research as well.

Johann von Goethe (German poet, 1748-1832) was very much interested in color perception and was adamantly opposed to the theories and experiments of Newton. Goethe emphasized the importance of intuitive observation which he applied to such problem areas as afterimages, contrast effects, shadows, and color blindness phenomena. His color theory, based on the notion that colors are mixtures of dark and light, is illustrated by the attributes he lists for yellow and blue (his two basic colors).

Goethe's theory of color appeared in 1810 and can be interpreted as a two-color (yellow-blue) theory or a four-color (red-yellow-green-blue) one (with red and green being derived colors). The phenomenologists have agreed that these four colors are the primary ones based on simple observation.

Ewald Hering (German physician and physiologist, 1834-1918) developed a "natural system of color sensations." The theory maintains that there are six primary sensations from which all color sensations derive. They fall naturally into three pairs of polar opposites: red-green, yellow-blue, and white-black. In contrast to Young and Helmholtz who were concerned with a theoretical explanation of color appearances in terms of *stimulus attributes*, Hering approached the topic from the point of view of analyzing *visual sensations*, that is, he emphasized the role of the observer. It was the sensations themselves which were perceived to be the "real facts" of interest. The Natural System of Colour (chap. 13) was developed on the color vision theory of Hering.

**Color Attributes  
(Goethe)**

<b>Plus</b>	<b>Minus</b>
Yellow . . . . .	Blue
Brightness . . . . .	Darkness
Light . . . . .	Shadow
Warmth . . . . .	Cold
Active . . . . .	Passive
Force . . . . .	Weakness
Repulsion . . . . .	Attraction
Proximity . . . . .	Distance
Acid . . . . .	Alkali

**Visual Perception—Gestalt**

*A danger to objective psychology—is to try to achieve the quantitative, the numerical, the experimental record as quickly as possible, or to regard as really valuable only those experiments which yield numbers and curves. Every research must employ those methods which are appropriate to its subject and to its state of development; what matters is not simply the imitation of the trappings of the exact sciences. In the most important areas of objective psychology, there is very much to observe which so far cannot be studied quantitatively either directly or indirectly. Thus the investigator will necessarily find himself on a bypath if he observes only the quantitative and leaves unobserved—and therefore without influence on his questions and his thinking—the other behavior of the subjects studied. Then he will not at all see the major part of his task; his theories will necessarily be one-sided and narrow.*

*Findings and problems of the rapidly advancing human phenomenological psychology can, it is true, lead immediately to quantitatively formulated experimental questions for objective psychology as well. But the scope of quantitative proof in this region has remained just about the same as its scope in human psychology. And even in the latter field, were not the points of view which are now being applied to objective psychology first achieved entirely in qualitative experience? Thus if every good question and also every meaningful quantitative experiment go back ultimately to such qualitative observation, then a simple methodological conclusion follows: The investigator must wander—again and again and over its whole extent—through this foundation of all inquiry and all experimentation. Of the total range of psychological investigation, even contemporary human psychology knows only parts. In this science we know how to make observations in special areas like perception and memory, but according to what laws a man, for example, reacts as a whole, "as a system," to life situations in which he is highly involved emotionally—about this we know astonishingly little as psychologists, and from such slight knowledge we cannot properly derive sharp questions for objective psychology. Thus for such cases, which concern the behavior of the organism as a whole, we remain dependent on observation within objective psychology.<sup>11</sup>*

<sup>11</sup> W. Kohler, *Gestalt Psychology* (New York, 1947).



Studies of complex visual phenomena paralleled physiological psychology and psychophysics and are traceable to the Gestalt movement in psychology. Leibnitz and Kant argued that an analytic approach was not applicable to the study of human behavior. The Gestalt psychologists supported this view and favored a *dynamic* interpretation of behavior. They argued that people respond to the environment in an integrated way and therefore that global (holistic) observations of behavior are necessary. That is, the person responds as an entity, and by using analytic methods of study, we are asking people to behave in a way that does not correspond to everyday life.

The greatest impetus for the Gestalt movement in psychology rested in the everyday experience of most people. Visual phenomena, such as the Mueller-Lyer and other illusions, were well known to many researchers and laymen. However, the early sensory psychologists could not account for these sensory experiences in their analytic approach to research. It was left to the followers of Gestalt psychology to initiate the first systematic investigation of these phenomena, and a theoretical formulation to account for the illusions.



Figure—Ground in Museum (NBS)

## The Müller-Lyer Illusion

*Straight lines are equal in length*

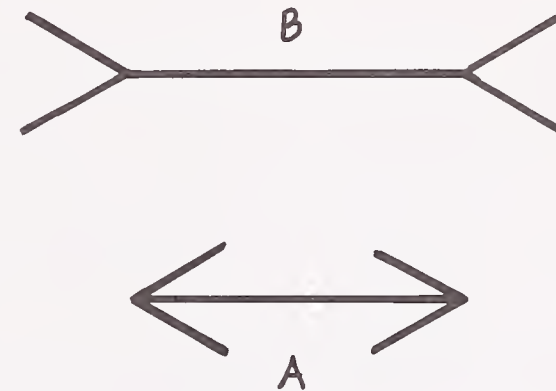

### Origins of the Gestalt Movement

The origin of Gestalt psychology resembles that of psychoanalysis. A bright researcher was faced with a problem which could not be solved using traditional methods and thereby was faced with the need to formulate an alternative explanation (hypothesis) and research approach.

Max Wertheimer (German psychologist, 1880-1943), generally credited as the founder of Gestalt psychology, broke with the past due to his findings in perceptual organization and apparent movement. As with Freud, his primary breakthrough involved an insight which questioned the very research framework assumed by his predecessors.

A major interest of Wertheimer was the study of apparent movements. His investigations of this phenomenon led him (and other Gestaltists) to reject the classical analytic research approach to perceptual phenomena. The methodology employed in his study followed classical principles, but the findings could not be explained by this theoretical framework.

The study consisted of two stimuli projected successively on different parts of the retina. Under proper conditions the subject reports that a movement can be seen. This apparent movement (termed the phi phenomenon) explains stroboscopic movements on which the motion picture industry is based. Wertheimer

used a **tachistoscope** to present simple geometric figures for a short time interval. He presented a figure twice, separated by time intervals which varied from experimental trial to trial. When the interval between presentations was very short (less than 30 msec) the perception was of both figures seen together. When the interval was long (above 200 msec) the subject perceived a succession of two. However, between these two intervals, the subject saw the "pure movement," *without seeing any object*. (Optimum interval was 60 msec.) He insisted that movement was an *immediate experience* which could not be explained or even examined using the analytic methods of traditional science.

Let us now consider a number of the other researchers who influenced the development of the Gestalt movement and the problem areas which interested them.

Franz Brentano (priest and philosopher, 1836-1917) provided a philosophical explanation for the appearance of illusions. He argued that physical phenomena are "acts." *When one sees a color, the color itself is not mental. It is the act of seeing that is mental. There is no meaning to seeing unless something is seen. The act always implies an object—refers to a content.*<sup>12</sup> Brentano, unlike Wundt, was not an experimental researcher. Instead, in arguing about perceptual illusions, he based his approach on the design of a critical experiment—a sudden insight or awareness of a phenomenon in contrast with the use of classical scientific methodology to

quantify phenomena. The subject matter of Gestalt studies lends itself to "all or none" responses—e.g., seeing or not seeing an illusion.

Erich Jaensch (German psychologist, 1883-1940) addressed a basic concern of the architect in his work—depth perception. He discussed phenomenology in terms of empty space and its "psychic" representation. In common with other Gestalt researchers, Jaensch was particularly intrigued by illusions. He was especially interested in *constancy* phenomena, that is, when characteristics of objects such as size and color do not appear to change in appearance even when there are changes in the physical world which "should" lead to such perceptual changes. His work on color transformation exemplifies this situation.

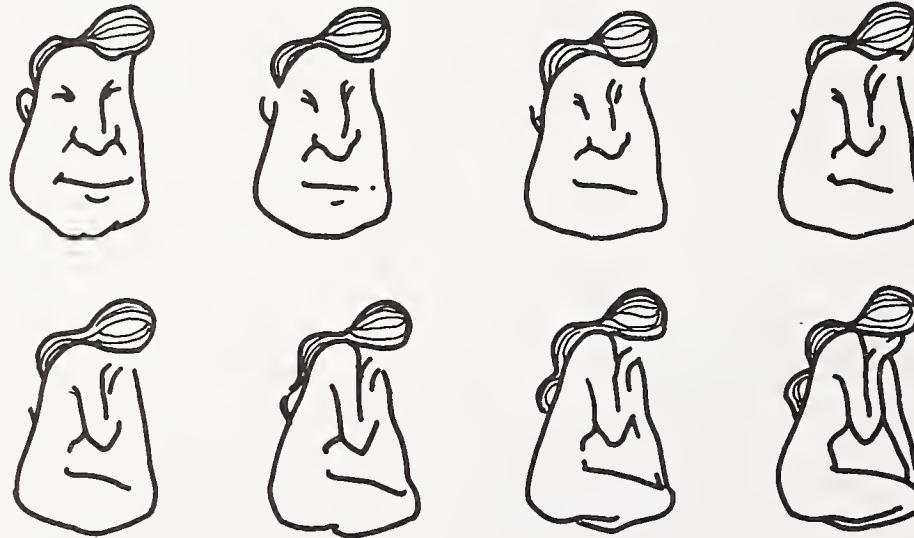

"Man-Girl" Figures are a part of a series of progressively modified drawings devised by Gerald Fisher in 1967.

### Schröder Stairs

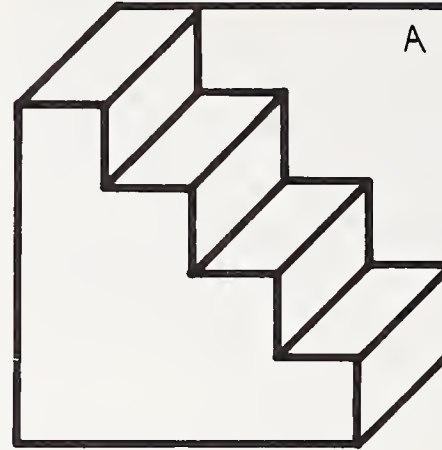

The work of other Gestalt researchers has been discussed earlier in chapter 11, and we will therefore go on to our next topic.

### Rabbit-Duck Reversible Figure

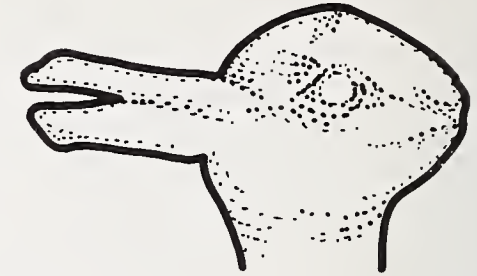

### Wundt's Illusion of Direction

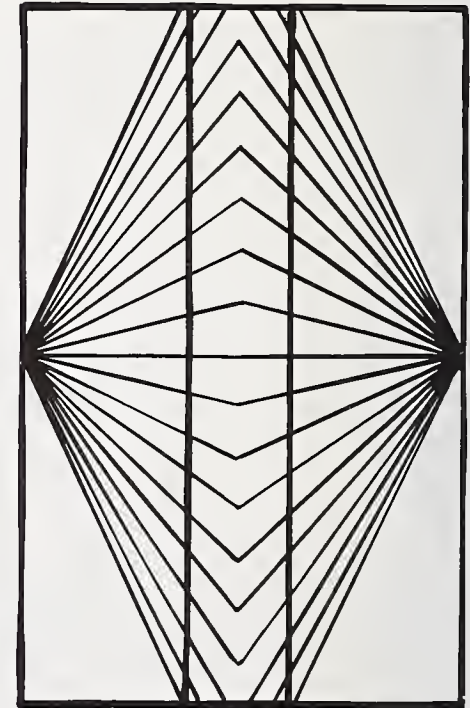

<sup>12</sup> Boring



## Differences Among Individuals

Another major field of study in behavioral research is that of differences between individuals. This problem area started with studies of genius in the population and later was expanded to intelligence testing in general and test development. This research has always employed statistical distributions of people, which in turn have led to survey research.

The study of individual differences is traceable to the early 19th century when mental and physical attributes of an extensive number of people were measured. The objective of this and later work on this topic has been to look at a large population and determine how characteristics are distributed among them—e.g., height, I.Q. scores, etc. The nature of the problems addressed led to the development and refinement of statistical procedures later used in many areas of social research—e.g., surveys. Another illustration of studies of population characteristics is exemplified by the work of early researchers concerned with mental health. The French physician Esquirol in 1838 wrote a two-volume treatise in which he made a distinction between people who were mentally retarded and those who were insane. He noted that many degrees of mental ability were evident, which varied along a continuum from normality to low-grade idiocy. (He found that language ability was the most sensitive indicator of intelligence level.)

Sir Francis Galton (English anthropologist, 1822-1911) pioneered several approaches to the study of man designed to determine how people *differ* from one another, in terms of a variety of attributes. His initial interest in the topic focused on determining the hereditary basis of genius, which later broadened to include the inheritance of other characteristics. These studies led to the examination of physical, sensory, and other characteristics of the general population which he wanted to relate to high intelligence—i.e., genius. He performed this task by devising a series of tests to determine how well people performed on a variety of tasks. In addition, he compiled anthropometric data to describe the physical characteristics of the people being studied.

One of the major contributions of Galton to psychological research is the development of the first large orderly body of information on many attributes of people. One important source of information was educational institutions which were induced by Galton to make anthropometric measurements and keep them on file. Galton also set up a laboratory at an international exposition where measurements of keenness of vision and hearing, muscular strength and reaction time were made in addition to anthropometric measurements.

Galton employed tests of ability, which were designed to exhibit differences in aptitudes among the general population. He was one of the first users of questionnaires and rating scales as well.

*At Greenwich (England) in 1796, N. Maskelyne dismissed D. Kinnebrook, his assistant, because Kinnebrook observed the times of stellar transits almost a second later than he did.*

*The error was serious, for upon such observations depended the calibration of the clock, and upon the clock depended all other observations of place and time.*

*The accepted manner of observing stellar transits at that time was the "eye and ear" method of Bradley. The field of the telescope was divided by parallel cross-wires in the reticle. The observational problem consisted in noting, to one tenth of a second, the time at which a given star crossed a given wire. The observer looked at the clock, noted the time to a second, began counting seconds with the heard beats of the clock, watched the star cross the field of the telescope, noted and "fixed in mind" its position at the beat of the clock just before it came to the critical wire.*

*This method was accepted and regarded as accurate to one or at least two tenths of a second.*

*. . . Had it not been for F. W. Bessel (1784-1846), this event, might have passed into oblivion. . . Bessel sent to England for a copy of Maskelyne's complete observations and determined to see whether this personal difference could be found amongst observers more experienced than Kinnebrook . . .*

*In 1820, he found an opportunity to compare himself with Walbeck at Konigsberg. They selected two stars for five nights. Bessel was found always to observe earlier than Walbeck. The average difference was 1.041 secs., with but little variability about the average. If Kinnebrook's error of 0.8 sec. was "incredible," this difference was even more so, though Bessel recorded: "We ended the observations with the conviction that it would be impossible for either to observe differently, even by only a single tenth of a second." Bessel presented the differences between two observers in the form of an equation ( $A-B=X$ ), which was referred to as a "personal equation."<sup>13</sup>*

<sup>13</sup> Boring

Since Galton's interests dealt with large numbers of measurements, he was faced with the problem of describing his findings quantitatively. This requirement led to the use of statistical methods appropriate for analyzing the differences found among the population. Galton, in applying statistical analysis to his findings, observed that inherited characteristics tend to approach the average (mean) value of a distribution of measurements. For example, sons of tall fathers are on the average, not as tall as their fathers while the sons of short men are taller than their fathers.

Of particular importance was his discovery that most characteristics of people are distributed among the population in a very regular way. Human traits such as height, weight, aptitudes, and personality characteristics approximate a **normal curve**. Furthermore, in general, the larger the group tested, the more closely will a distribution of scores approximate this curve. The normal curve permits us to say not only something about the average score (**mean**) but also about the distribution of scores (**standard deviation**). (See chap. 21 for a discussion of statistics.)

### Height Variations Among Populations (Rapoport)

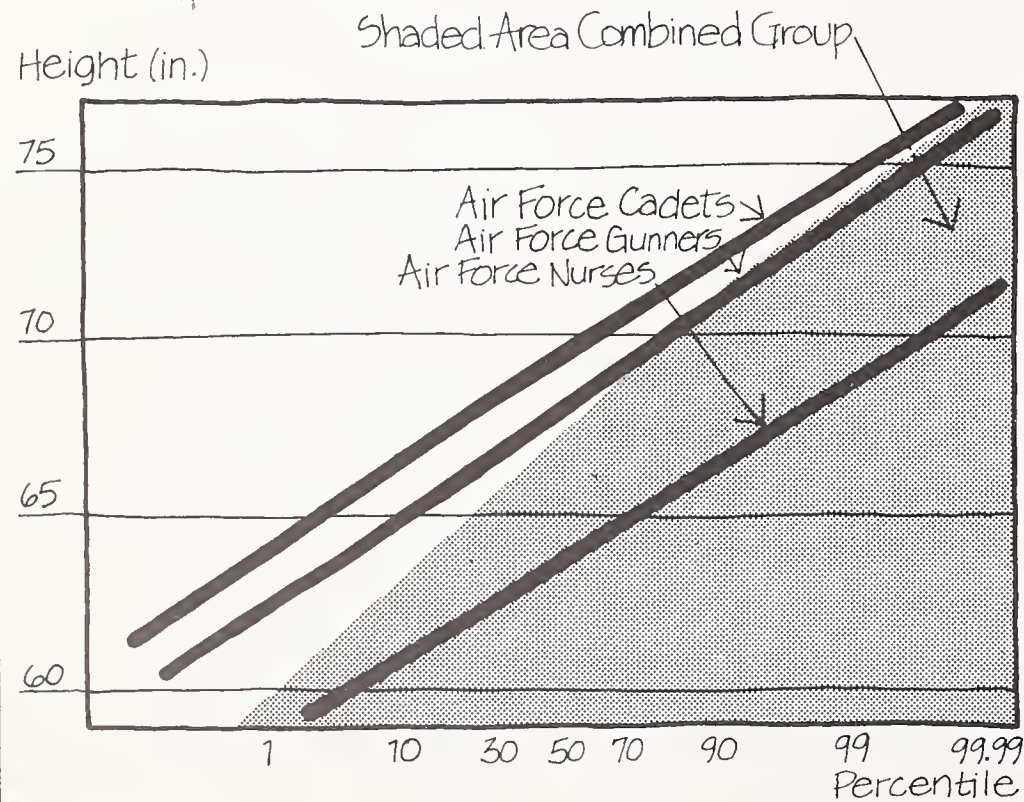

### Population Sizes and Weights (Roberts)

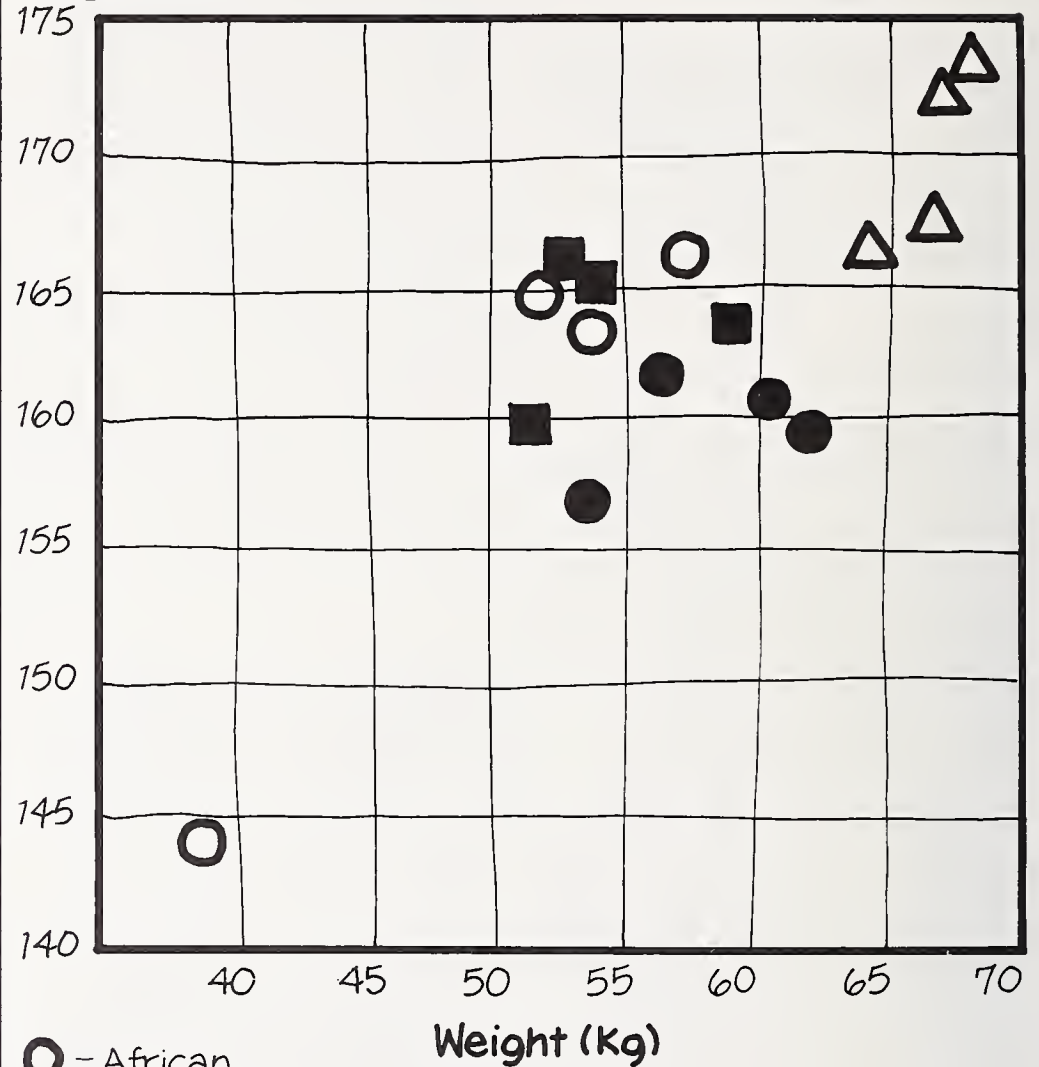

Survey research which constitutes a substantial proportion of M/E investigations owes a great deal to the application of statistical analyses which are dependent on the normal

curve for testing findings. Furthermore, the work of Galton led the way to later research which pursued in detail the study areas which he initiated.



## Why People Act As They Do—Motivation and Personality Factors

We have stressed the importance of obtaining “facts” concerning M/E relationships. However, in the attempt to obtain objective information, we should be continually aware that man also has emotional, psychological, and cognitive experiences and needs which exercise important influences. As we noted earlier, these subjective and highly individualized influences are frequently the ones which are of primary concern to architects, e.g., the desire to create warm, intimate, pleasing, inviting environments.

The development of research methods to explore the motivations and feelings of people marked the origin of clinical psychology and psychiatry as research disciplines. The work of Sigmund Freud, for example, illustrated the need to treat people whose illnesses could not be traced to physical causes—but to personal experiences and/or personality characteristics. While many of the approaches used to determine why people act as they do were developed to diagnose abnormal behavior, later refinements and applications dealt with the motivations of normal people. The research methods in both cases were intended to obtain information about views that individuals were either unable or unwilling to express.

## Psychoanalytic Techniques

If we seek the origins of qualitative research methodology, a logical starting place is the work of Freud, an Austrian born physician, researcher, and founder of psychoanalysis. Freud was trained in the use of traditional physiological and medical methods but found them to be of limited usefulness in the treatment of several behavioral abnormalities.

He developed psychoanalysis in order to understand the symptoms exhibited by patients whose illnesses could not be attributed to physical impairments. Freud used hypnosis as a therapeutic device for treating hysterical patients suffering from paralysis, mental confusion, and other difficulties. The technique consisted of hypnotizing the patients and encouraging them to talk about their difficulties. After this therapy a temporary improvement in the subject's condition frequently resulted.

Freud concluded that hypnosis was not the important aspect of this therapeutic approach—rather it was the talking out of the problem. He therefore eliminated hypnosis from his treatment and instead induced patients to relax and say whatever came to mind, to “free associate.” While this occurs, the analyst not only attends to what is being said, but also to the emotions displayed when the patient is talking. During free association sessions, as well as when interpreting dreams, Freud was concerned with motivational factors, both conscious and subconscious. He considered motivations to be major influences on behavior. Freud's work

pointed toward the importance of being aware of unexpressed values and beliefs when investigating problems such as determining the requirements for building occupants. Freud also pioneered the development of methods which could be used to “tap the subconscious.”

Although psychoanalysis is perhaps the most popularly known technique used to learn about the inner world of people, it represents only one of many methods which was developed to achieve this purpose. Another method, as noted earlier is the use of projective techniques.

## Projective Techniques

Projective techniques present the respondent with a stimulus which is characterized by some degree of ambiguity. The respondent is then required to give a spontaneous response to that stimulus. It is not the respondent's response *per se* that is important, but the manner in which the stimulus is interpreted.

These procedures taken together are very valuable in determining what factors influence people in making judgments and decisions concerning all topics, including building satisfaction. They constitute a versatile and powerful research approach, whose full potential has not yet been realized. Some of the more commonly used techniques will be briefly described.

One method developed by Saul Rosenzweig (psychologist) employs cartoons to encourage the subject to “project” into a given situation. A drawing or cartoon with “balloons” to represent speech is given to a subject. One of the balloons is left blank and it is the task of the subject to fill it in.

## Cartoon Test (Rosenzweig)



Other researchers have employed photographs to determine how subjects respond to ambiguous situations. The objective in both instances is to present subjects with depicted situations which are highly ambiguous, thereby enabling people to describe situations which they are unlikely to respond to if addressed directly—i.e., emotionally tinged ones such as strong prejudices.

## Thematic Apperception Test (TAT)



Projective tests are also often quite time-consuming and expensive. Most of the tests must be administered on an individual basis. Trained personnel are required to score the tests and results often vary depending upon the scorers' individual interpretations. And, finally the validity of these interpretations is subject to much controversy.

Since most people communicate verbally, it is not surprising that considerable effort has been expended on developing methods which obtain information from verbal material. One such technique is termed "sentence completion." The respondent is presented with a number of incomplete statements which are to be completed with a single word, several words, or entire phrases. The sentence beginnings can vary greatly in subtlety and degree of ambiguity. Spontaneity is particularly important with the sentence completion technique. As in the case of the other projective methods the sentence completion method provides the researcher with a technique which is limited only by the imagination of the person gathering data although as with other research methods, professional experience is of paramount importance.

In the methods already mentioned, the subject is presented with a good deal of information to "structure" the test situation. The situation under which the behaviors are examined is somewhat narrowly defined. Other techniques have been used which are much more "open ended," in which subjects have more freedom to express themselves. This objective is sometimes accomplished using verbal techniques—sentence completions starting with *I . . .*, *My . . .*, *Buildings are . . .*. An alternative approach is to ask people to make drawings or sketches of objects or maps of areas similar to the procedures employed by Lynch and other M/E researchers. (See Chap. 6.)

One very effective method of obtaining information has been the development of game situations. For example, child psychologists for many years have used dolls and doll houses to learn how children feel about themselves, their parents, their home environments, etc. By playacting with the dolls, children are encouraged to express themselves in a way that is not acceptable otherwise.

The advantages of projective techniques are several. The indirect presentation permits the true purpose of the test to be disguised, and therefore makes faking difficult. Faking can often be a problem with questionnaires or other straightforward techniques in which the respondent "sees through" the test. The indirect presentation also allows for an in-depth probe of areas which may be beyond the individual's conscious awareness or behind his social facade. These techniques can help researchers to penetrate many barriers such as:

- Awareness—People often do not know why they have particular attitudes.
- Irrationality—People respond to accepted cultural norms based on habit and acceptability.
- Self-incrimination—People defend their self-images. Taboo opinions are not openly expressed.
- Politeness—People prefer to say positive rather than negative things.

While open-ended methods offer the opportunity for subjects to express themselves freely, there are several disadvantages inherent in this approach. People differ considerably in terms of experience, information, drawing ability, and ability to verbalize. In addition, the wealth of data on many topics often makes it difficult or impossible for a researcher to organize the information in a manner which permits the solution of the problem being investigated. That is, after collecting a good deal of data, the solution is no closer than it was before conducting a study.

## Sentence Completion Test

Sometimes noise makes me . . . . .

The lighting I like best . . . . .

What I like most about my kitchen is . . . . .

I wish my neighbors would . . . . .

In my spare time I like to . . . . .



## The Hawthorne Studies

Our final “historic” investigation is the “classic” Hawthorne studies conducted at the Hawthorne works of the Western Electric Company between 1927 and 1939.<sup>14</sup> These studies were instrumental in highlighting the complexity of “real world” research, performed in actual work environments, and they indicated the importance of having a “multivariate” viewpoint rather than limiting research to single parameter studies. Although many years have passed since the completion of the Hawthorne studies, the research and methodological problems that were identified as a result of the studies are still with us today. Because of the similarities of the objectives of these studies to much of M/E research, they will be considered in some detail.

The Hawthorne Studies consisted of a series of five large-scale investigations. Each succeeding study was developed as a result of questions raised by the preceding one. The initial objective was a “simple” and pragmatic one—to alter environmental conditions in order to increase the quality and quantity of production.

The first investigations were designed to determine the effects of varying the levels of illumination on three departments in the production process: inspection of small parts, assembly of relays, winding of coils.

In the small parts department, average levels of illumination of 3, 6, 14, and 23 foot-candles were used (independent variable). The production (dependent variable) of the workers varied, but not in any systematic relationship to the amount of illumination.

In the other two departments, the intensities of illumination used were 5, 12, 25, and 44 foot-candles. The production rates in these departments were increased when compared with previous performance, but the changes could not be attributed to changes in levels of illumination.

The problem was thought to be more complex than originally conceived, and a second experiment was designed, using more sophisticated procedures. This second study took place in one department and two groups of workers participated. The reason for this change in procedure was to account for possible differences among the work tasks, or the characteristics of the people in the departments, which might have accounted for the results in the first study. For example, if the inspection of small parts required very little illumination, while the assembly of relays required more illumination, comparing the results obtained in one department with those achieved in another one wouldn’t make much sense. It would be like comparing “apples and oranges.” Similarly, if the

workers in one department were more capable of doing their jobs than those in another department, any differences obtained in the experiment might be attributed to the differences in skill levels between the people being compared, rather than to levels of illumination. In effect, “differences in skill” could operate as an unstated and unknown “independent variable.”

As a means of overcoming these difficulties, the second investigation was designed in such a way that all of the workers performed the same task. In addition, comparisons would be made between workers who were equated in terms of such factors as experience and average production. The researchers also wanted to guard against any spirit of competition between the two groups. They were concerned with determining *typical* performance measures, not those obtained during competitive conditions which would not likely continue beyond the duration of the study, and could “mask” any effects associated with illumination. The study design called for one group to work under relatively constant illumination (control group) while the other (test group) worked under three different illumination intensities.

The results of the second investigation added to the confusion because both groups increased production noticeably.

A third experiment was then designed to further refine experimental procedures. In this investigation the control group worked under a constant intensity of 10 foot-candles. The test group began with an intensity of 10 foot-candles, with the intensity reduced systematically over time until the level was 3 foot-candles. *Levels of production were maintained.* In a follow-up study, levels were reduced still further, “to the levels of ordinary moonlight,” also without a decrease in production.

The last of the illumination experiments was conducted in the coil winding department. At first, the intensity of lights was increased on a daily basis. The workers reported that they *liked* the brighter lights. An electrician then changed the bulbs but lighting intensity was *not* changed. The workers reported that they enjoyed the *increased* lighting (despite the lack of change). The next phase of the investigation involved a “decrease” in illumination. When illumination levels *were* decreased, the workers indicated that the lighting was not as pleasant as it had been earlier. Finally the workers were told that illumination levels would be lowered and although bulbs were replaced, the levels were the same as they were before. The workers *again* indicated that the “lowering” of illumination levels was unpleasant when compared with the previous condition. During all of these conditions, there was no real change in production.

<sup>14</sup> F. J. Roethlisberger and W. J. Dickson, *Management and the Worker* (Cambridge, Mass., 1941).



In short, a series of studies conducted over a considerable time period designed to determine the relationship between levels of illumination and production indicated that *no direct relationship* could be demonstrated. (These findings have been replicated time and again in illumination research and noise research as well, when simple cause-effect solutions have been attempted.)

When environmental characteristics (lighting levels) could not account for the productivity levels of workers, the Hawthorne investigators started looking at other factors (variables) which might have accounted for the findings. The second major study (lasting 5 years) pursued the answers to a series of questions.

- Do employees actually become tired?
- Are rest pauses desirable?
- Is a shorter working day desirable?
- What are the attitudes of employees toward their work and toward the company?
- What is the effect of changing the type of working equipment?
- Why does production fall off in the afternoon?

In trying to answer these questions, the investigators did not systematically vary environmental conditions (lighting levels). Instead, the independent variables that they used focused on such factors as rest pauses, wages, incentives, and changes in supervision.

As in the first study, the findings again were difficult to interpret because no simple relationship between any of the independent variables and performance was evident. At the conclusion of the study the experimenters inferred that they had *not* studied the relationship between monotony or fatigue and performance, but had conducted a sociological and psychological study. By trying to control one set of variables, they had introduced a new one—a social situation involving changes in attitudes and interpersonal relations. The investigators then began to question many assumptions that they had previously made. They realized that the study actually was a complex one, and that it was not possible to predict the effect of a single factor, when it was embedded in a complex

“environment”—physical, psychological, and social.

Follow-on studies pursued questions of attitude, interviewing techniques, formation of work groups, communications, and other subjects which form the basis for the discipline of industrial psychology.

The Hawthorne Studies have been presented in some detail because they provide a constant reminder to those who tend to oversimplify the difficulty of obtaining a meaningful answer to what appears to be a “simple question.”

We will conclude this chapter by presenting a brief discussion of the development and current status of research in the area of user requirements.



Office Workers (NBS)

## Investigations of User Requirements

Perhaps the most thorough investigations of user requirements are among the earliest ones reported. In the 1930's, 1940's, and 1950's, Svend Reimer (Swedish researcher) used a variety of techniques in collecting user data associated with the home. Reimer stated that:

*Housing standards and housing design assume some relation between the physical and human attributes of housing. Accepting the fact that light and air relate to certain infections, standard ratios of window and floor space are established. In the belief that crowding affects property values, family or community welfare, occupancy is regulated. The scientific study of such relations leads to the formulation of humane and effective housing standards and to the development of truly functional design.*<sup>15</sup>

Reimer's research methods were then adapted by researchers who did several studies for the John Pierce Foundation in the 1940's. The techniques used by these early researchers are largely synonymous with most of the field methods used later. The most impressive feature of their approach is that they employed all the methods, not just one or a small sample. Their investigations serve as a model which has not been replicated since that time. They collected their basic data in the following ways:

- Activity Log—The husband and wife each kept a detailed log of the

<sup>15</sup> S. Reimer, “Livability—A New Factor in Home Value,” *The Appraisal Journal*, 14 (April 1946).



activities they engaged in over an 8-day period.

- Interviews—A trained interviewer using a structured questionnaire obtained detailed information on activities such as sleeping, child care, dressing, and eating.
- Observations—A trained investigator made systematic observations of the house, furnishings, and possessions.
- Measurements—A researcher made detailed measurements of room sizes, furniture, and other possessions.
- Sketches—Drawings were made of furniture arrangements within the home.
- Expert Panel—In the design of special purpose facilities, such as a sickroom, experienced investigators made recommendations based on available data obtained in hospitals.
- Human Factors Studies—In the design of kitchens special studies were conducted using anthropometric data and requirements for space determined by the activities being performed.
- Projective Techniques—A series of open-ended questions was asked to identify some basic needs of the respondents. (If no monetary constraints were imposed, where and how would you live? What would you tell an architect to include in a house specially built for you?)
- Simulation—Studies were conducted using small model furniture

placed in a cardboard room space. (What bedroom furnishings and arrangements do you want if money is no object?)

Following the studies conducted by the John Pierce Foundation, research in the United States concerned with the relationship between environment and behavior tended to be isolated within specific disciplines. In 1970, Proshansky, Ittleson, and Rivlin published a book, *Environmental Psychology*, which served to pull the field together. Through this book the authors were able to define the field of environmental psychology and to identify the problem areas in this new and growing discipline. The authors stress that the only adequate definition of a field is in terms of theory. But, since the field of environmental psychology does not yet have a theoretical orientation, the authors provide an operational definition: environmental psychology is what environmental psychologists do.

According to the authors, environmental psychologists work in four major areas. One area concerns basic psychological processes as they related to the environment. A second area deals with behavioral concepts such as territoriality and privacy. These concepts are specifically related to the way an individual relates to the environment. The authors maintain that as the field of environmental psychology matures, more concepts of this nature will be developed. The relationship between social institutions and environmental design constitutes a fourth area. Finally, the area of environmental planning is explored. It is

in this area that the need for communication between the behavioral scientists and planners becomes critical.

All of these areas have one unifying theme—each is concerned with the relationship between environment and behavior. And although at the present time environmental psychology must be defined operationally, the authors stress that the field must ultimately be based upon theoretical concepts. *Environmental psychology is an emergent discipline that must evolve as an interdisciplinary superstructure of theoretical constructs and principles rooted in the basic formulations and empirical findings of many separate disciplines.*<sup>16</sup>

Robert Gutman continued to define environmental psychology in the same way as Proshansky, Ittleson, and Rivlin. He edited a book, *People and Buildings*, the purpose of which is to make known and accessible some of the more important works in environmental psychology. Gutman emphasizes that a great deal of research needs to be done if the potential contributions of the social sciences to design are to be fully realized. On the other hand, he acknowledges that much research has already been undertaken and many concepts have been developed but these contributions are not readily available to the designer. It is for this reason that he has collected some of the more important works and published them in his book.

<sup>16</sup> H. M. Proshansky, W. H. Ittleson, and L. G. Rivlin (Eds), *Environmental Psychology: Man and His Physical Setting* (New York, 1970).

A more recent contribution of social and behavioral researchers to the M/E field has been in the area of post occupancy evaluation. In her book, *Easter Hill Village*, Claire Cooper has presented a user evaluation of the design solutions employed at Easter Hill Village, a public housing project in California. Cooper interviewed the designers of the project to determine the objectives of their design and the physical means by which they satisfied these objectives. She also interviewed the sponsor of the project to find out what effect budget restraints had on the physical design. Finally, detailed interviews were conducted with a large number of residents.

## Conclusion

This overview of historical research is intended to suggest the general streams of thought, from the origin of experimental work in psychology to the current issues addressed by M/E researchers. Obviously, many other theoretical and research studies strongly influence the M/E study area as it exists today, but these contributions must be described elsewhere and by others.



*A Questionnaire Interview (NBS)*



# 20

## Surveys

Assumptions in Survey Research

Classes of Surveys

Survey Administration

    The Survey Interview

        Interview—Standard vs. Nonstandard

        Recording of Responses

    Self-Administered Questionnaires

Questionnaire Development

    Question Content and Wording

    Questionnaire Design

Conclusion

One of the most widely used methods of obtaining information in M/E studies is the survey and more particularly the questionnaire.

It is doubtful, however, whether even the best surveys can be employed as the sole source of information in defining requirements of building users. The design and conduct of *valid* surveys is a research technique which requires as much expertise as any of the other methodologies discussed in this book. Surveys have probably been misapplied and misinterpreted in M/E studies more than any other method mainly because they *appear* to be such a simple approach to data collection.

The chief reason for the popularity of the questionnaire survey is the flexibility it affords the researcher. As long as questions can be formulated, it is possible to organize these questions in the form of a survey. For this reason, surveys have been used for the purposes of planning, evaluation, and decision making as well as for research.

Survey techniques became very popular in the 1930's and 1940's especially with the advent of opinion polling and the requirements associated with advertising. (Magazine and newspaper circulation, radio listening and later television viewing habits all were subjects of surveys to determine how many people used these media. This information, in turn, largely influenced advertisers in terms of how to most effectively use their advertising budgets.)

In reviewing the survey literature, C. Glock (sociologist) indicates that researchers seem to have studiously avoided defining a *survey* because any definition broad enough to cover all of the methods employed would be so general as to be meaningless. He makes the point, however, that there is general agreement that the data collected must be standardized in some format to enable the experimenter to perform a statistical analysis, which enables meaningful conclusions to be drawn from survey findings. This goal of standardization does not assume any prescribed format but takes into account that even open-ended questions should be amenable to some kind of coding and analysis. Who the subjects are, how they are selected, what data are collected and in what way, are all subject to variation, depending on the requirements of the study. Individuals are most often the subject of surveys although larger entities such as groups, organizations, and communities are sometimes sampled, particularly by sociologists.

The **sample** of respondents to be questioned in the study is selected on the basis of sharing characteristics with the **population** of interest. For example, when we want to determine the needs of the aged in terms of special residential requirements, the respondents of the study are members of that age group. With respect to the number of respondents necessary to question, this decision is made primarily on the basis of statistical requirements. That is, a large enough sample is employed to

enable the researcher to make a decision. For research purposes, the larger the size of the sample, the better (this is true for all research not just surveys). However, increasing sample size increases costs and lengthens the time required to complete a study

and these very practical concerns often dictate the number of subjects ultimately used in a study. (References are cited in the appendix if more information is desired concerning survey design and analysis.)

## Sample Size is an Important Factor in Research

small sample:



large sample:

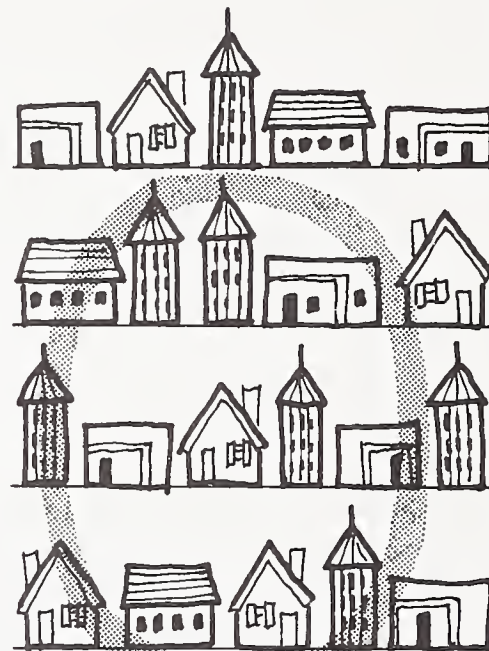

## Assumptions In Survey Research

Although particular surveys are likely to differ from one another as to subject matter, approach, and the factors just noted, they share a number of basic assumptions and characteristics. The most important of these concerns the type of data obtained.

Surveys are based on verbal responses of subjects. By employing this methodology, researchers assume that verbal responses to questions are *indicative* of other forms of behavior. For example, let us assume a person is asked whether he would buy a home with a specified set of characteristics. The response is "yes." Does this mean that given the resources and opportunity to make such a purchase, that the individual would *behave* that way, i.e., actually buy the house? Perhaps, but there is no assurance that verbal statements of intent will be followed through by the actual behaviors of concern. Public opinion pollsters have long been aware of this dilemma and carefully refrain from stating that a preference for a candidate at a given time is a *predictor* of voting behavior at a later date.

Another basic assumption associated with many questionnaire surveys concerns the willingness and ability of respondents to provide meaningful information. A respondent who participates in a survey may not provide information of any usefulness for one of several reasons, such as:

- lack of information on the topic discussed,

- lack of any opinion,
- misunderstanding of the question,
- difficulty formulating a verbal response,
- unwillingness to respond truthfully,
- fear of being misquoted.

The survey researcher must therefore learn how to win the confidence of a respondent, and how to keep him motivated and interested until the required data are collected. The investigator must make every effort to develop a survey instrument free from bias, whether his own or that of the respondent.

D. Lucas and S. Britt (psychologists) summarized a number of personal respondent characteristics which may lead to biased findings:

- People are dominated by their self-interests. They resent long interviews or questionnaires and are impatient with responding to questions that are irrelevant to them.
- Personal privacy must be respected. Respondents are reluctant to discuss matters of income, age, and health unless they clearly see the need for providing such data.
- People are inclined to deny certain motives. The need for social approval is shared by all respondents. There is a reluctance to openly express views which are not generally accepted in the community.
- People often rationalize their acts. *Logical* reasons are frequently given for performing actions, but the explanations might not be accurate. In many instances, people do not know why they act as they do.



## Classes of Surveys

Surveys are sometimes divided into one of two major classes, based primarily on the approach taken in collecting data and the function served by the survey. A. Oppenheim (survey researcher) describes these classes as *descriptive* and *analytical*.

The *descriptive* survey enumerates people and objects and is typified by the census and by opinion polls. It is usually designed as a means of gathering and organizing a body of facts. The questions posed and therefore answered take the form of "how many" and what proportion, rather than "why." The concern of the analyst is primarily to compare distributions of people, objects or events. An example of this type of approach is demonstrated by a survey conducted by the University of Illinois on interest in retirement housing. The survey was undertaken to determine the type of housing arrangements preferred by retired individuals connected with the University. The survey resulted in a listing of features preferred with no attempt to probe why some features were preferable to others.

The "why" questions are treated in the *analytical* surveys. While the compilation of discrete categories of information may serve a useful function, it is often necessary to determine interrelationships among variables. This examination requires the sort of experimental manipulation of variables usually associated with laboratory research. For this reason,

the analytic survey, which is designed to clarify associations and provide explanations, is sometimes termed "the poor man's experiment." The analytic survey presupposes a theoretical framework suggesting causality among variables. In this respect it sharply differs from the descriptive approach. Analytic surveys may be further divided into several approaches.

*Panel design* involves repeated measurements on particular subjects. The same respondents are subjected to identical measurement operations at different times to enable computation of individual scores during each experimental phase.

This procedure is useful when innovative building designs are employed. For example, when open space planning was first used in schools an assessment by teachers with limited experience with this approach might be highly favorable, primarily because of the novelty associated with a "break with the past." However, a better test of the acceptability of the open space plan would be to obtain several repeated evaluations by the same teachers (and students) who have had prolonged experience with the approach. This approach is necessary to determine whether the novelty effect has worn off, and would thereby provide more valid data.

*Trend studies* are another example of analytic investigations. In this instance equivalent subjects are measured at different times to determine any changes in population habits. The decennial census is the most widely known application of this approach. Another important use of trend studies is exemplified by the current energy shortage where more information is needed concerning how fuels are used and how this usage has changed over time.

*Prediction studies* are investigations which employ different measurement methods on the same respondents at different times. For example, when impact assessments are made, it is often necessary to predict the way that people would react to a change in their environment. Let us assume that a new type of lighting is proposed to

be installed in an office building. A researcher might be asked to determine the attitudes of people toward the new lighting. In response to the inquiry, a questionnaire survey is conducted before a decision is made to determine whether the occupants are for or against the new lighting. The results of the study might indicate that people are generally favorable toward the lighting. Partially on the basis of these reactions, the lighting is installed. Then some time after the lighting has been in use, another survey is conducted to determine whether the attitudes of the people have changed as a result of their experience with it. The findings of this study might confirm or contradict the results of the earlier predictive investigation.



Office Furniture Lighting (NBS)



When studies of this type are conducted, the researcher must be sensitive to several possible sources of error. It is important to employ different methods of assessing attitudes in this "before and after" study to minimize the possibility of introducing errors in later evaluations. One possible source of error is that respondents might remember their original responses to questions, thereby influencing later ones. Another problem is that subjects of surveys are likely to compare notes after the first evaluation, and the judgments of one person may be influenced by this *feedback* information during later administrations of the same questionnaire. These issues are of critical importance in *evaluative* research of buildings, when it is necessary to evaluate a building more than once in order to determine changes over time.

### Survey Administration

One useful method of examining the available data collection methods is on the basis of personal interaction between interviewer(s) and respondent(s). Many techniques rely on a face-to-face interaction between both participants, while others are based on impersonal procedures. As might be expected, in still other instances, combinations of both techniques are employed.

When questionnaires are sent through the mail, the researcher's tasks are to design an appropriate set of questions and then analyze the findings—not to interact with respondents. At the other extreme is a situation where the experimenter has not yet developed a formal questionnaire, but has a number of general topics to be covered. In this instance, it is necessary to follow up responses to questions in a manner that suits the purpose of the study. Maximum flexibility is required, as well as a thorough knowledge of how to conduct interviews and elicit information which relates to the problem area of interest, both requiring a high degree of skill.

The overriding factors which will determine the most effective method of collecting data are the goals of the study, the quality of information available on the topic being investigated, and time as well as cost considerations. To the extent that the problem is not well defined, it is necessary to "open up" problem areas which could not be anticipated. This goal may be accomplished by the wording of a self-administered questionnaire, by means of an interview situation or by a combination of the two, an interview which is guided by using a questionnaire.

Let us first consider the interview situation.

### The Survey Interview

The procedure that often comes to mind first when one thinks of a survey is an interviewer asking a respondent a series of questions and recording responses when they are obtained. A slight departure from this approach is an interviewer asking questions of a group of people (for example, all of the members of a family).

As survey techniques have become more sophisticated, the interview situation has become quite complex, necessitating a delicate interaction between the respondent and the interviewer. Instead of asking a series of questions, the interviewer is now often required to administer a complex series of tests which are designed to obtain subtle but quantifiable data on attitudes and opinions. Indirect measures are often desired by the researcher and they are obtained using photographs, adjective descriptors, maps, and a variety of other techniques that have been described more fully in other areas of this report (see Parts II and III).

Since data collection often occurs in a setting where two people are interacting, there are many possibilities of introducing biases due to the characteristics and expectations of each of the participants. Some of these problems will be treated in detail because of their influences on the validity of the data obtained in surveys.

A. Blankenship (market researcher) indicates that the function of the introduction and opening statement in an interview situation is to create rapport. Since it is desirable to conduct the interview in a relaxed and rather informal manner, it is the task of the interviewer to set the respondent at ease and foster this atmosphere for the duration of the interview. It is often necessary to devote a good deal of time and effort for this purpose because although the interviewer regards the question and answer session as routine, the respondent may be ill at ease in what is often a very novel situation. If the respondent is not relaxed, the quality of the responses may be dubious.

The interview situation is one in which there is an interaction between at least two people and therefore personal factors cannot be ignored in any overall research plan. The interviewer must occupy some "role" during the interview, i.e., expert, detached observer, helpful friend, etc. The particular role which is appropriate depends largely upon the purpose of the interview. There are some general guidelines, however. The interviewer should not appear ignorant or totally naive to the respondent because this would reinforce the idea that the responses are not understood. When the subject matter is highly specialized, a certain degree of sophistication is needed by the interviewer, especially when there is need to pursue a topic under discussion.



The interviewer should not be in a position to control sanctions affecting the respondent, that is, he should be *outside* the power hierarchy in which the respondent normally finds himself. If he is not, the respondent will attempt to put himself in such a light as to gain the interviewer's support and avoid his censure, and will not talk freely about any topic where he fears he might discredit himself. It is important finally for the interviewer to retain his detachment and studiously avoid social contacts with respondents during the course of the study. Differences in race, sex, age, or religion may result in responses that are dependent more on the backgrounds of the participants in the interview situation than on the subject matter under investigation. Just the fact that the interviewer is unfamiliar to the respondent and therefore a stranger, might produce findings that are not objective. The *relative* status between the interviewer and respondent (as perceived by the respondent primarily) is also a possible source of bias. This criticism has been a major one in studies conducted in disadvantaged areas. Interviewers with middle-class backgrounds have typically collected data from people who did not share these backgrounds. Another major source of error is the differences in language patterns between interviewers and respondents which cause a very real communications barrier.

Hall indicates that even during interviews communication occurs at different levels of consciousness and is not restricted to verbal exchanges. He describes a *silent language* whereby the individual reacts to subtle influences such as gestures and other body and facial movements. They serve as both a *stimulus* and a *response* to things said and done. An interview situation is rich in this type of non-verbal communication and often it is a determining factor in the success or failure of the interview. An interviewer may unwittingly convey attitudes, feelings, and judgments. For example, he may nod or frown thereby indicating his approval or disapproval of a respondent's comments. In this situation the interviewer has influenced the response and the interview is no longer unbiased but reflects the interviewer's opinions or biases.

### Silent Language (Hall)



**Interview—Standard vs. Nonstandard**

After it has been decided to use the interview to collect data, it is necessary to adopt a general format in order to define the interview situation. Basically, two procedures are available to the researcher. One consists of the use of a *standardized format* whereby a maximum effort is applied toward planning every detail of the interview. Questionnaire content, instructions, training and selection of interviewers are based upon the assumption that the data collection will be centrally planned and controlled. The interviewers will serve as an extension of the person responsible for planning the study. Essentially any deviation from planned procedure is defined as experimental error. This approach emphasizes the importance of obtaining a data base of information that is comparable on a case-to-case basis. The responses tend to be more reliable and errors attributed to the wording of questions are minimized. Since the format is a rigid one, it is likely that the administration of the survey will take less time than a less direct approach.

In contrast to the highly standardized interview, there are researchers who advocate a more flexible approach. One such approach is the **focused interview**, which employs an interview guide with a list of objectives and suggested questions. Using this technique, an interviewer can explore new topics as they are introduced and can follow up in detail when this appears to be a useful approach. The advocates of this flexible format stress that it permits a standardization of *meaning* rather than of the less im-

portant mechanical aspects of the interview. Another advantage is that the responses are considered more valid in that respondents are permitted to reply in their own way rather than to an artificially restricted set of alternatives. Finally, the flexible approach enables the interviewer to make more use of his skills and experience in following up appropriate leads. In determining which procedure should be selected for a particular study, the following factors should be taken into account:

- Availability of trained interviewers—A flexible approach makes more demands on the know-how of the interviewer than does the standardized approach. It takes experience to recognize responses that should be followed up and skill to direct the interview in an appropriate direction at the pace required to complete the interview. In those surveys where a large number of people is to be included in the sample, it would probably be very difficult to find enough experienced interviewers or to train a sufficient staff. The types of skills required for non-standardized interviews are often acquired on-the-job rather than in the classroom because they involve personal interactions rather than a mastery of information.
- Scope of the survey—When a large number of people is to be interviewed, the time necessary to complete each questionnaire is a key ingredient toward successful completion of the study. For example, the rigid format lends itself to more concise administration than does the flexible one and is therefore more likely to be used as a cost saving factor.



In subject areas not well defined, a flexible approach is a logical one. This enables trained interviewers to establish the limits of the problem and the range of responses that might be expected. Since the standardized format presupposes a thorough information base (the responses which are judged to be appropriate are all preselected), any "novel" reply would have to be considered a source of error. When these errors constitute more than a very small proportion of responses, the results of the entire survey are suspect. At the other extreme, some areas have been researched for a long period of time and the need becomes one which is primarily quantitative. Standardized interviewing practices permit sophisticated statistical examination of the data and the drawing of conclusions with confidence and are therefore preferable. In short, when the variables are fairly well identified, there is less need for the flexible approach permitted by the nonstandardized interview.

### Recording of Responses

In the interview survey planning process, the actual recording of responses is a topic that is often neglected. Since these responses comprise the "raw data" obtained, it is difficult to overrate the importance of recording them thoroughly and accurately. A variety of techniques have been employed to accomplish this purpose:

- Write up from memory—The interviewer minimizes notetaking during the interview to bolster a free exchange of views and to emphasize the conversational tone of the interview. This method has the fault of permitting distortion of findings due to any biases that the interviewer has. Major points in the interview are emphasized and others are eliminated altogether. Consistency of viewpoint is likely to be recorded at the expense of any contradictory statements that might have been made. Apart from distortion, a good deal of information is lost because of
- the inability of the interviewer to remember all that had been covered during the session.
- Field coding—The interviewer uses a form to code specific answers into predetermined categories. This approach is very well adapted to questionnaires consisting of closed questions. The alternatives can be presented to the respondent and readily checked by the interviewer.
- Field ratings—The interviewer is provided with a set of rating forms. On the basis of the interviews he makes judgments on the major issues covered in the survey. This method is best employed by interviewers thoroughly trained and familiar with the subject areas of concern. This method is not used too often.
- Verbatim notetaking—The recording of responses word for word while the respondent is being interviewed is attempted by some interviewers who are concerned with completeness. Very little systematic

work has been done to evaluate this approach but it obviously minimizes any personal interaction between the respondent and the interviewer.

- Mechanical recording—In some instances, the respondent talks into a microphone and his answers are recorded. A problem associated with this technique is the requirement to have the interview typed for evaluation purposes. Typing becomes as expensive as interviewing because of the sheer wealth of material that is recorded. Also respondents may "clam up" or "show off" when confronted with a microphone.

### Self-Administered Questionnaires

The most widely known use of self-administered questionnaires is the mail survey. For many years researchers and opinion pollsters who typically use large samples and/or draw from a widely dispersed population have used this method of data collection. Its primary advantages are that it is quite cheap to administer, it is standardized, it can be designed for simple data analysis, and can be mailed to a large number of people rather inexpensively. From the standpoint of the respondent, it can be filled out at a convenient time and place and produces minimal disruption from usual activities.

Mail surveys do have a number of shortcomings. The problem being investigated must be well defined and the questions phrased in simple and unambiguous terms because there is no way of providing clarifying information. People with low intelligence,

### Different Methods of Recording Responses



Write up from memory



Field coding, rating;  
Verbatim notetaking

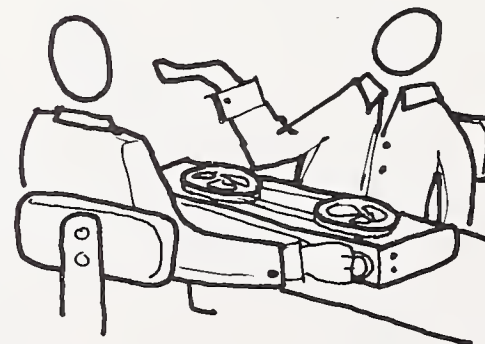

Mechanical recording



limited education, or reading difficulty often have to be excluded from the sample. The questionnaire must be designed in such a way that item sequence is not important because respondents often will not answer questions in order of appearance on the form. Factual questions are not appropriate because the respondent has the opportunity to look up the answer or ask someone else for the information. If information is desired from a particular member of the family, it is impossible to ensure that other opinions have not been solicited. The lack of an interviewer leads to shallow responses because there is no opportunity to assist in providing a context, to probe for more information and, possibly most important, to help to motivate and encourage the respondent with assurances about the importance of the task. Mail surveys typically have low response rates; the proportion of responses received is considerably lower than that obtained during interviews. This poses a sampling problem because in many studies nonrespondents have been found to have different characteristics than respondents. One method employed to increase response rate has been to use reminders in the form of letters and telephone calls.

The telephone has been used by researchers as a followup to the mail survey and diary approaches (see chap. 5). In addition, in recent years, survey researchers have increasingly employed the telephone as a method of collecting the data they seek. This method overcomes some of the deficiencies associated with mail surveys, e.g., the rate of responding is

increased and there is personal contact which enables some clarification of questions. The telephone contact with respondents can be made by nontechnical people, but it is necessary to train them not to volunteer information (or respond to questions) which would prejudice the findings of the study.

### Self-Administered Questionnaires



Mailing Survey



Telephone Interview

### Questionnaire Development

The items on a survey can be written in several different ways. The amount of available information in a subject area is an important determinant of the approach employed. Where a relatively new area is being explored, it is logical to ask questions that are open-ended, because the problem must be adequately defined before meaningful measures are possible. In a sense, it is first necessary to understand the problem thoroughly to be able to ask the correct questions in an appropriate form to produce objective and valid data. The greater the amount of information available, the more feasible it is to concentrate on obtaining responses that are objective and quantifiable. Several of the methods used in item construction will be discussed.

An **open-ended question** (*How do you feel about this office?*) permits the respondent to reply in any terms that appear to be appropriate. It is a realistic and natural way of posing questions. As noted earlier, a primary advantage of this approach is the opportunity it affords the researcher to better understand the problem being addressed. This result is accomplished partially by encouraging respondents to think about general problem areas—which often provides insights into variables which were unknown or unrecognized by the researcher. Another “payoff” to the researcher is that there is an opportunity to probe into general problem areas, thereby identifying pertinent variables more precisely than was possible before such a study.

Open-ended questions have a number of shortcomings. Subjects differ greatly in terms of how quickly they respond and the depth of their responses. The researcher should be aware of the possibility that a few intelligent and/or articulate subjects might provide the preponderance of the responses, thereby biasing a study. In such a situation, the investigator must control and limit the amount of information provided by a single subject. There is a number of other difficulties associated with this approach. For example, pertinent replies are often not stated because they are too obvious, gradations of opinion are difficult to handle, provincial and slang expressions are frequently used and difficult to interpret. Generally, the responses obtained to open-ended survey questions are so rich and varied that the researcher is faced with a formidable task in trying to make sense of the data. The organization and particularly the analysis of data of this type provide a major challenge to any researcher.

Since open-ended questions are by their nature unstructured, it would not be appropriate (or possible) to formulate any guidelines indicating how they are used.

The same question noted earlier may be made into a **dichotomous item** by forcing the respondent to choose between two responses. (*How do you feel about this office?* Favorable \_\_\_\_\_, Unfavorable \_\_\_\_\_.) In this instance the subject's response is highly structured in that he is not free to reply in any way that he might think appropriate.

### Dichotomous Items

Do you have a window or windows in your office or work area?

- Yes
- No

Are you able to see as much of the outside world as you would like from your desk?

- Yes
- No
- Don't know/no opinion

Does your office ever become so noisy that you find it difficult to work?

- Yes
- No

Cantril indicates that provision for "don't know" and "no opinion" response is necessary most of the time. Some provisions often must be made for qualified responses; that is, those not neatly fitting the categories included in the survey. He also indicates that when two-way questions are used, alternatives should be explicit rather than implicit. Special attention should be devoted toward expressing the negative in detail when necessary because it is often the victim of oversight. (Instead of: *Do you think this is a good or bad office?*, it is better to ask: *Which statement best describes your attitude? This is a good office \_\_\_\_\_ or This is a bad office \_\_\_\_\_*.)

Another approach sometimes employed with dichotomous items is the paired comparison technique in which the respondent matches two items which he feels express compatible ideas or are in some way equal.

### Paired Comparison

Please read the following pairs of items and check the one item in each pair which you feel is most important to have in your office.

- a window
- comfortable temperature
- comfortable temperature
- good light
- good ventilation
- freedom from noise

By definition items having more than two response categories are **multiple choice** (although "no opinion" responses are discussed as a third category under dichotomous items). The design of these items in many respects is more difficult than the others. It is particularly important that the choices available be mutually exclusive as well as exhaustive. Cantril notes that the response categories should be balanced in that if there are more alternatives that are positive than negative, the findings can be expected to reflect this distribution. When several alternatives are available for response, care should be exercised not to produce items that are extremely complex. If too many alternatives are available, the task of selecting an appropriate one is very difficult and time-consuming. Also, there is a tendency for many people to select the *last* alternative because it was read most recently and is therefore relatively fresh in the mind of the respondent. The multiple choice format is especially good when gradations of attitude or opinion are appropriate. It also has the advantage of calling attention to a range of possible alternatives.

### Checklist Evaluation

Which of the following best describe the view out of the window closest to you? (Check as many as apply.)

- |                                      |                                      |
|--------------------------------------|--------------------------------------|
| <input type="checkbox"/> satisfying  | <input type="checkbox"/> open        |
| <input type="checkbox"/> limited     | <input type="checkbox"/> bright      |
| <input type="checkbox"/> simple      | <input type="checkbox"/> uncluttered |
| <input type="checkbox"/> pleasant    | <input type="checkbox"/> frustrating |
| <input type="checkbox"/> confined    | <input type="checkbox"/> complex     |
| <input type="checkbox"/> dim         | <input type="checkbox"/> boring      |
| <input type="checkbox"/> stimulating | <input type="checkbox"/> unpleasant  |

### Multiple Choice Items

Does your office ever get warm enough to make you feel uncomfortable?

- often
- sometimes
- only occasionally
- never

Do you prefer working by natural light, artificial light or a combination of natural and artificial?

- prefer natural
- prefer artificial
- prefer combination

Two variations of the multiple choice technique are *rank ordering*, which is useful in determining relative priorities, and *checklists*, which provide another means of obtaining information from respondents.

### Rank Order Evaluation

Listed below are some of the advantages of windows. Please rank them from 1 to 10 in order of their importance to you. "1" should be the most important advantage, "10" the least important.

- let you tell time of day
- let sunshine in
- let you know what the weather is
- let in warmth
- let you see what's going on outside
- provide a way for fresh air to enter
- give a change of view to break monotony
- provide light for plants



One method of combining some of the features of "open" and "closed" questions was tested by Suchman. His basic questionnaire consisted of a series of multiple choice items using a structured format. However, interspersed among the questions on a random basis were follow-up questions such as: *Can you tell me a little more about that?* This method was employed to accomplish several purposes. It provided information indicating whether respondents were replying in a manner consistent with the assumptions underlying the design of the questions. That is, the researcher works using some well-defined frame of reference, and although through instructions and through the content of question items it is assumed that the respondent shares this point of view, the researcher seldom obtains any verifying data. The random probe is likely to provide reasons for selecting responses and these reasons can clarify the respondent's frame of reference. Another purpose served by the probe is to determine how well the item is understood. A detailed reply provides valuable insight into this factor. Finally, information provided in detail by the respondent may provide insight into meaningful ways of altering or expanding the questionnaire to accomplish the purpose for which it was designed. Most of these features have in common the one aspect that they enable the researcher to upgrade the quality of his questionnaire.

### **Question Content and Wording**

S. Payne (survey researcher) made these observations concerning the content and wording of questions:

*Assumptions made by the researcher should be identified. (Some examples of assumptions are: People know what they are talking about. There is a basis for opinion. Question items are understood by the respondents.)*

*The words could, should, and might are often used interchangeably although they convey different meanings. (Could—possibility, should—moral connotation, might—probability.)*

*Survey questions should have the same meaning to everyone.*

*Most studies are conducted by college trained people who have difficulty talking to those with grammar school educations. This takes the form of either talking down to them or talking over their heads.*

*Items which are complex or deal with particular subject matter must be carefully constructed.*

*In a list of numbers, those near the middle of the list or near the average will be selected most frequently.*

*In a list of ideas, those positioned at the beginning and at the end will be most popular. (Especially the first one listed.)*

*In a verbal statement of two ideas, the one stated last is most frequently selected.*

*A Checklist for questions:*

*Does it mean what we intend?*

*Does it have any other meanings? If so, does the context make the intended meaning clear?*

*Do any words have more than one pronunciation? Is there a word of similar pronunciation that it might be confused with?*

*Is a simpler word or phrase suggested in a dictionary or thesaurus?<sup>1</sup>*

**A. Blankenship** summarized his experience as follows:

*Questions should be phrased in concrete and specific terms rather than abstract ones.*

*Whenever possible, questions should refer to objective behavior capable of empirical verification rather than to opinions or attitudes.*

*The necessity to measure and validate responses should be kept in mind.*

*In wording a question, the intensity of phrasing influences responses. (Always and almost always produce distorted data because the respondent can often think of an exception.)*

*The content of a question should not be offensive to the respondent.*

*Questions should be worded in an unemotional and unbiased fashion.*

*Question content should interest more than a small minority of respondents. (If people are indifferent to an item, their responses will not be given careful thought and the result might be misleading.)<sup>2</sup>*

**H. Cantril** (survey research psychologist) indicates that:

*There is a need for clarity of expression.*

*(Some items are too vague to permit precise answers. Others are obscure in meaning and produce worthless responses.)*

*Items should be worded without stereotyped expressions. (They lead to predictable and useless answers.)*

*The vocabulary used should be suitable to the level of education of the population sampled.*

*The use of overly technical and unfamiliar words should be avoided.*

*Questions should be unambiguous. (Ambiguity leads to responses that are often confusing and/or worthless.)<sup>3</sup>*

When employing a fully structured questionnaire, the goal of the researcher is to present respondents with forced choices. That is, responses must be made in a prescribed way. Forced choice questionnaires are sometimes based on verbal expressions (yes, no), may be quantitative (rate the acceptability of your office on a scale of 1 to 5, with 5 being the "high" end of the scale), or may combine both features. The number of optional responses available to the respondent can be varied whether verbal or numerical responses are desired.

<sup>1</sup> S. L. Payne, *The Art of Asking Questions* (Princeton, 1951).

<sup>2</sup> A. B. Blankenship, *Consumer and Opinion Research: The Questionnaire Technique*, (New York, 1943).

<sup>3</sup> H. Cantril, *Gauging Public Opinion* (Princeton, 1944).

## Questionnaire Design

Investigators have specified methods designed to organize the individual items on a questionnaire into a unified *test instrument*. The rationale in many instances is to promote a favorable interview climate for the conduct of the study (to promote a feeling of rapport between the interviewer and the respondent).

Let us examine the context devised by one researcher which illustrates the type of information desired, and the approach used to collect data.

G. Gallup (statistician and pollster) devised an approach to the sequencing of questions in public opinion research. He advises the early use of **filter questions**, which are primarily factual in nature. In this manner the interviewer is able to determine the extent of knowledge possessed by the respondent about the topic under study. The next series of questions are of the open-ended variety. The purpose served by this approach is to get the subject to talk freely about the problem; the free flow of information provides insights and enables the responses to be obtained in some depth. The next step recommended is a series of yes-no items which fulfill the requirement to "vote" on the issue and meet the demands for objectivity associated with data processing and analysis. After the tabulation of responses, the respondent is questioned about his reasons for the responses that were given. Finally, the interviewer asks about the strength of feeling concerning the topic under discussion.

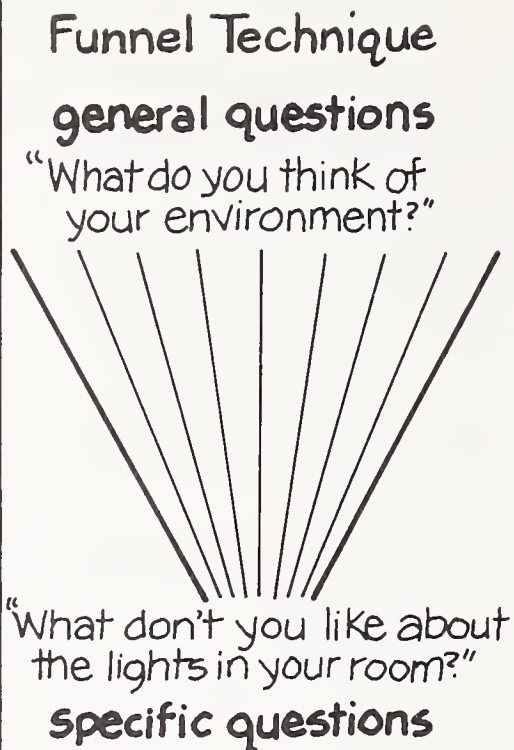

## Gallup's Questionnaire Design Strategy

Subject Area	Questions
Awareness	Will you tell me what . . . means to you?
Attitude	What, if anything, should be done about . . . ?
Reaction to Specific Proposal	It has been suggested that . . .
Intensity of Feeling	How strongly do you feel about this?

From: Gallup, George. *Qualitative Measurement of Public Opinion: The Quintamimensional Plan of Question Design* (American Institute of Public Opinion, Princeton, New Jersey, 1947).

Lucas and Britt also dealt with the question of survey design strategy and made the following points:

- Questionnaires should be as brief as possible.
- The first question should be one that can readily be answered without difficulty.
- The sequencing of questions is important. Questions should not be asked which might prejudice the response to later questions. For example, if we wanted to determine the optimal dimensions of a bedroom, we should not ask respondents first, "How large is your bedroom?" If we did, then the earlier response might influence the later one.
- Several difficult questions should not be asked in succession. By making it difficult for respondents to reply, there is a likelihood that they will become defensive and ill at ease.

- The sponsor of the research should not be revealed, since the respondent may have strong feelings for (or against) him, thereby compromising the value of the responses.
- Finally, if there are questions which are likely to arouse strong feeling, then they should appear at the end of the survey where they will not influence later responses.

## Conclusion

Questionnaire surveys are a powerful research "tool" when used by trained researchers. When misused, however, they can be the source of misleading findings contributing to erroneous conclusions. We noted earlier that in our opinion, they have been naively used and seriously misapplied in many M/E investigations. There is a logical reason for this outcome, namely that surveys are deceptively simple in their appearance. As a result, anyone interested in obtaining information is tempted to conduct a survey, often without any training or insight which might induce caution before plunging ahead. Architects who would not think of entering a laboratory to perform an experiment without proper training do not show the same reluctance to design and carry out a questionnaire survey. Yet, both research methods require understanding and training if the data obtained are to be meaningful. In many instances, *more* training and experience are needed in survey studies than in laboratory investigations.



## Classification, Measurement, and Statistics

Classification

Sampling

Efficient Sample Design

Measurement

Measurement Errors

Normal Probability Curve

Conclusion

Part II shows how scientific methods are used to develop information and reviews several of those employed in M/E studies. It also describes problems whose solution will lead to a better understanding of how people are affected by their surroundings and hence to the design of more responsive buildings.

Qualitative and quantitative techniques used to develop information in the biological, behavioral, and physical sciences apply equally to solving M/E problems. They consist of classification procedures, measurement approaches, and statistical methods used to plan and evaluate research. Such research methods or statistical analysis procedures are central to all forms of research.

What follows is an introduction to the subject. The authors hope the reader will see fit to pursue the topic further due to its importance in M/E research. (See bibliography.)

Architects and behavioral researchers want better M/E information. Their goals, however, are not the same. The architect wants data to help make appropriate design choices. As B. Skinner (psychologist) describes the goal of behavioral (and other) sciences: *It is a search for order, for uniformities, for lawful relations among the events in nature. It begins, as we all begin, by observing single episodes, but it quickly passes on to the general rule, to scientific law... Science sharpens and supplements experience by demonstrating more and more relations among events and by demonstrating them more and more precisely.*<sup>1</sup>

The architect and the traditional researcher therefore start from a similar premise—the need to observe single “episodes,” but they part company thereafter. Unfortunately, many M/E studies do not go beyond the architect’s immediate need for better user data. With proper research planning, not only can these needs be met, but at the same time, information can be developed to serve other purposes too, such as to help formulate and test general rules and scientific laws. This advances the professions of M/E research and architecture.

This chapter discusses theory, concepts, and mathematical models. This kind of framework enables a researcher to evaluate and select appropriate statistical procedures and sampling approaches.

### Classification

E. Wilson (chemist) writes:

*All sciences start with the process of selection of classification. The universe is too vast and complex to be treated as a whole; so a manageable part of it must be chosen for observation and investigation. Furthermore, all scientific laws are based on classifications . . . the basis for a given classification is an entirely practical one: What is the classification to be used for ?*<sup>2</sup>

<sup>1</sup> B. F. Skinner, *Science and Human Behavior* (New York, 1953).

<sup>2</sup> E. B. Wilson, *An Introduction to Scientific Research* (New York, 1952).

In M/E research, the number of possible classifications approaches infinity. Building types, activities, and characteristics of potential users are examples of important M/E classifications. They are definable in terms of properties which are readily observable, and therefore capable of being at least seen, if not measured. As Wilson notes: *Scientifically, classification is of the utmost importance because of the empirically established fact that it is possible to set up certain classes in such a way that mere membership in the class renders highly probable, the possession of attributes other than those used to define the class. In other words, certain properties appear to be associated with one another.*<sup>3</sup>

Let us first consider a proposed building as a member of a class of buildings called "residential," e.g., apartment houses. Multiple-occupant residential buildings are the population of interest. (The population is the total group of individuals and objects to which a study might pertain.)

The researcher now faces a problem. Countless buildings are included in the classification "residential." While these buildings are likely to share many features, they will differ from one another in important ways. For example, most residential buildings have common spaces indoors and outdoors, and facilities for disposing of garbage and performing other required activities such as washing and drying clothing.

On the other hand, while some residential buildings have common spaces equipped with comfortable seating facilities, television sets, and even fireplaces, in most others these amenities are lacking. The classification of "residential buildings" may therefore not be appropriate if the research is to identify activities performed in common spaces. A finer classification breakdown may be required, e.g., luxury residential buildings. As Wilson notes, membership in the class of luxury residential buildings would likely be linked to classes of other attributes of

interest related to building features (e.g., presence of tennis courts, swimming pools) and attributes of people living in such buildings (e.g., wealth, education, status).

If the problem is to assess the activities performed in common spaces of luxury residential buildings, then we have redefined and narrowed the population of interest from all residential buildings to luxury buildings. The research task is still formidable. There are countless luxury buildings, and one cannot study all of them. How then can the required information be obtained?

Why not determine the correct number of tennis courts to accommodate the residents? A luxury building with tennis courts is arbitrarily selected and usage patterns are observed—when, how frequently, waiting time to get a court, etc. This observational data could then be supplemented by a questionnaire survey to obtain a measure of satisfaction with the tennis facilities—for example, to see if residents have tried and failed to obtain access to courts, and so no longer try to use them.

Assuming data has been compiled indicating tennis court usage for the building, to what extent do these findings apply to all such tennis courts? In Wilson's terms: *under what circumstances is this process of generalization justified? This is one of the most fundamental human questions, a question which practical scientists have to answer daily.*<sup>4</sup> To answer this question we need to select for observation a number and type of individual members from a class (e.g., tennis courts in luxury buildings), since all class members cannot be examined. This procedure is called *sampling*.



High-Rise Residential Building (NBS)

<sup>3</sup> Wilson

<sup>4</sup> Wilson



## Sampling

In most research, very few of the possible number of observations and measurements are actually made. (At best, a limited number of luxury buildings can be examined.) The nature of the sampling process is likely to determine the success of such an *inductive* study—one based on a limited set of observations intended to represent a class of events, objects, etc. Unbiased sampling is critical if the measurements are to be representative of the population. An approach termed **random** sampling is used, whenever applicable, to minimize sampling bias. The major requirements for a random sample are: (1) Each individual or object in the population must have a known (e.g., equal) chance of being included, (2) Selection of one individual or object should not affect the selection of another.

### Random Sample:

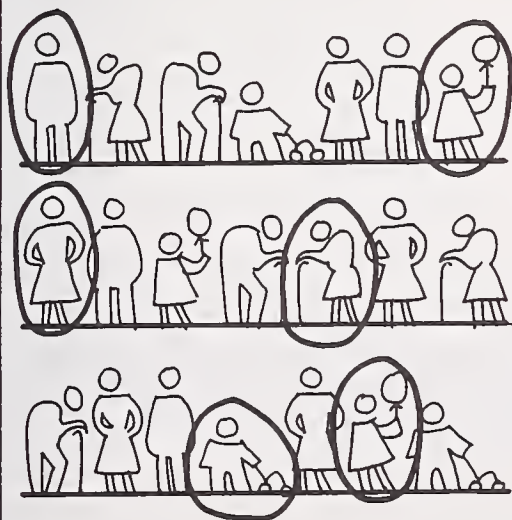

Random sampling is typically accomplished by using tables of random numbers. Assume that the study of luxury residences is confined to a community with 100 such buildings. Each building in the population of 100 would be assigned a different number. If a 10% sample were considered adequate, then 10 random numbers would be chosen to select the particular buildings to be studied.

In some instances, it may be appropriate to take a **stratified sample**. If the population has certain known characteristics, such as 25% low-rise, and 75% high-rise luxury buildings (with tennis courts), then the sample although selected randomly, could reflect this stratification.

### Stratified Sample:

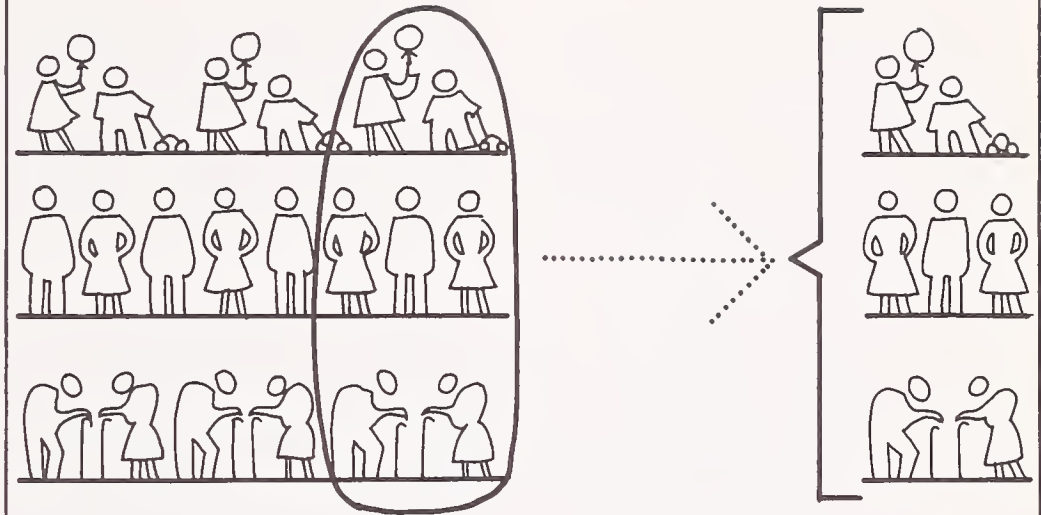

While the number of people, buildings, activities, etc. being sampled is an important factor (sample size), what matters more is the efficiency of the sample—that is, the extent to which the members of the sample represent the important attributes in terms of the research being performed. For example, if a larger sample of luxury buildings were examined but included in the sample were many buildings housing elderly people who could not play tennis, then the data collected on court usage would not apply to building residents who were younger.

### Factors in Selecting Sample Group



Who uses building?

## Efficient Sample Design

Ideally, if we wanted to determine what particular people do in a given situation, we would observe them. In our example, since the building does not yet exist and we have no way of knowing who the occupants are, this procedure clearly cannot be followed. We must therefore decide what factors (variables) associated with building characteristics and/or the potential occupants are important when user requirements are developed. Assume we want to determine what facilities should be provided for the prospective occupants—for recreation and other desired or required activities. One research approach is to administer a questionnaire.

How do we determine the respondents of the questionnaire?

We want a sample of people who are likely to respond to questions in the same way as the building residents would, if they could be identified and interviewed.

A favored approach is to start with a building having features like the one being designed and to do a limited study—a pilot investigation. Suppose that on the basis of the pilot study, the responses to questions by older people differ from those of younger ones.

The two groups would appear to have different requirements. These findings suggest that during a full-scale study a conscious effort must be made to include younger and older people among the sample, if the results are to be useful (assuming that the planned building will have elderly people). The survey therefore would consist of at least two sub-samples, elderly and younger people.

This sampling procedure has important implications for the size of the study, since we need a minimum number of observations to ensure believable research findings due to statistical concerns to be discussed later. The research problem is to determine how much data must be collected to make a decision, i.e., whether the responses (measurements, observations) of groups being compared are different in important ways. For example, how can we reliably determine whether age is an important factor when examining user requirements in residential buildings?

Once the sample is divided into two components (elderly and younger), the minimum sample size possible is twice what it was before age was treated as an important (independent) variable (when each variable is to be measured with equal precision). Similarly, if pilot findings showed that user requirements differed with respect to sex and building type (e.g., high-rise and low-rise), the survey design would become very complex; the number of experimental groups doubling with each additional variable.

## Study Design—Complexity, Subjects

Observations (Minimum)	Stratification Variables	Design, Subjects	
10		10	
20	Age <ul style="list-style-type: none"> <li>• Old</li> <li>• Young</li> </ul>	Old	Young
40	Age <ul style="list-style-type: none"> <li>• Old</li> <li>• Young</li> </ul> Sex <ul style="list-style-type: none"> <li>• Male</li> <li>• Female</li> </ul>	Old	Age Young*
80	Age <ul style="list-style-type: none"> <li>• Old</li> <li>• Young</li> </ul> Sex <ul style="list-style-type: none"> <li>• Male</li> <li>• Female</li> </ul> Building Type <ul style="list-style-type: none"> <li>• High Rise</li> <li>• Low Rise</li> </ul>	Old	High Rise Age Young
		Sex M.	10
		Sex F.	10
		Sex M.	10
		Sex F.	10

\* It is not always necessary to double the total sample size for each added variable. For example, if the quantity being studied is affected by age and sex independently (no interaction), then age and sex effects may be estimated by samples of 10 when only 5 subjects are sampled in each cell.



## Measurement

What is meant by measurement?

*The measurement of individuals and objects may be of various kinds, and may be taken to varying degrees of precision. When individuals or things have been ranked or arranged in a series with respect to some attribute or trait, we have perhaps the simplest sort of measurement. Children may be put in order for height, weight, or regularity of school attendance; salesmen may be ranked for years of experience, or amount of sales over a year; advertisements or pictures may be ranked for amount of color, or for cost, or for sales appeal....*

*Measurements of individuals may also be expressed as scores. Scores are usually given in terms of time taken to complete a task, or amount done in a given time; less often scores are expressed in terms of difficulty of the task performed, or excellence of the final result.<sup>5</sup>*

Measurement takes many forms. Some measures require a simple procedure and little equipment. For example, air temperature measures may be made by looking at a thermometer and reading the position of mercury on a scale. On the other hand, if we wanted to determine the effects of temperature changes on a person we might require sophisticated physiological recording equipment to measure heart rate, pulse, skin temperature, and sweat rate.

<sup>5</sup> H. E. Garrett, *Statistics in Psychology and Education* (New York, 1953).

For M/E information to help the architect it should be stated in quantitative terms whenever possible. The data should result from careful observation and measurement procedures and be presented in a form which helps the architect make informed design choices. The level of precision required for a measurement is dictated by the type of decision to be made. If the research goal is to make recommendations for acceptable room temperatures in a building, then measures of how people respond to small temperature differences, e.g., 1-2 °C, are an important research consideration, both to ensure adequate thermal comfort and for energy usage implications.

### Measurement Errors

Measurements and observations are subject to error. It is equally true for a classification task, such as determining whether a given residential building should be classified as "luxury" or not, and the case where measurements are made by reading a thermometer. While the magnitude and frequency of errors will be influenced by the difficulty of the measurement or observation task, errors are present in even the simplest task. The researcher's goal is therefore to reduce error size by appropriate controls, and then to estimate the size of errors which cannot be eliminated.

Four kinds of measurements were identified by S. Stevens (psychophysicist): **nominal, ordinal, interval, and ratio scales**. They differ from one another according to their mathematical properties, i.e., their use of numbers.

The nominal scale is the simplest. It uses a number as a means of identification. The number is a label only and serves the same function as a name (e.g., the number on the uniform of an athlete). The most widespread use of the nominal scale is as a means of classification. For example, if we categorized buildings into types, we would have a nominal scale as long as each building is placed in only one classification category—i.e., the categories must be mutually exclusive. Numbers cannot be manipulated, e.g., dividing, adding, or multiplying them.

An ordinal scale may be used to rank items, for example, to determine which of five possible colors are preferred by prospective occupants of a building. One way to determine the best choice is to give color samples to all, and ask each to rank the colors (i.e., 1 to 5). The colors would then be assigned numbers in accordance with their average rankings. This final ranking will indicate only the order of preference. We would know which colors are rated as being more (or less) acceptable than all others, but we could not say *how much difference* there was between adjacent ranks.

An interval scale goes one step beyond the ordinal scale. Numbers not only reflect the rank order of items but also the relative amount of distance or difference between items. Stevens illustrates this concept by saying that temperature (Fahrenheit or Celsius) and time are examples of intervals which permit quantitative comparisons, i.e., the day may be divided into hours, minutes, and seconds; and these intervals may be used to show the extent of time differences being compared.

The ratio scale has all the properties of the above scales and, in addition, has a fixed zero point which may be used as a frame of reference. A ratio scale enables ratios, fractions, and multiples of any measured quantity to be computed. Most physical qualities (e.g., length, weight, etc.) are measurable by ratio scales.

The key quality of a ratio scale is that it permits one to count things. It is the level of scale used when we count people, objects, buildings, and events. This fact is often overlooked in discussions of measurement, because it is so basic and common. Finally, ratio scales allow sophisticated mathematical models and procedures to be used to analyze and understand M/E relationships.



The relationship of experimental design, statistical and measurement factors will now be discussed in a hypothetical case study. The study is illustrative only, and designed to highlight major issues. It is not intended as a comprehensive treatment. *Case Study: Area requirements for a common activity room (e.g., TV viewing, conversation).*

Assume that our task is to further define user requirements for a planned residential building. A pilot study has suggested that a room is needed where residents can meet to talk to one another and watch television. Measurements of such rooms in several similar buildings have indicated that they range in area from 150 square feet to 400 square feet (13.5 sq. m to 36 sq. m). The research problem is to develop information to decide the appropriate room size.

Many procedures are available. One approach is to conduct a comprehensive study, using the method used in the pilot investigation. This means examining a sizable number of residential buildings with similar occupancies, determining whether they have rooms for the desired purpose and if so, measuring them. After compiling and analyzing these findings, the room dimensions might be selected on the basis of statistical criteria—e.g., the average size.

Another way of developing the desired information is a questionnaire survey. A sample of multiple-occupant buildings could be selected and their residents questioned about the desired size of an activity room, and/or the degree of interest expressed in having a room for this purpose. If the question about size is not asked specifically, size might be inferred on the basis of expressed interest and design data on spatial requirements for people.

Surveys of room dimensions and of people are indirect indicators of room usage. Our goal is to develop information concerning appropriate room size based on actual usage patterns.

The reasoning for this research approach is as follows. The best room size would be one which would accommodate most of the people who would like to use the room, most of

the time. A smaller room would be filled to capacity too often; a larger one would seldom be used to its potential—thereby wasting space which could be set aside for other activities—e.g., indoor activities such as ping-pong. The working hypothesis is that the best sized room is one which during peak occupancy, meets the needs of most building residents most of the time. Data will be based on field observations of a representative sample of 20 similar buildings with activity rooms of the sizes indicated previously. Room size and peak occupancy data will be recorded and statistical tests performed to determine the degree of relationship between peak usage and room size. If room size is a determining factor of usage, then decisions will have to be made as to the optimum size of the television room based on other tradeoffs.

The first step in designing an experiment is to simplify the situation. While activity room areas would be likely to vary almost continuously in size if the population (complete set) of such rooms were examined, we will test two classes of room size—small (between 150 and 225 sq. ft.) (13.5 and 20 sq. m) and large (between 300 and 400 sq. ft.) (27 and 36 sq. m). The room sample examined will consist of 10 rooms which fall into each of these classifications. Research observations will be made by counting the number of people using each room at 3-hour intervals for the time period between 8 a.m. and 11 p.m. (6 per day). Since a single measure (per hour) is insufficient because of measurement errors, each room will be observed 10 times, based on a random sampling procedure.



Residential Building (NBS)

### Room Occupancy Study Design

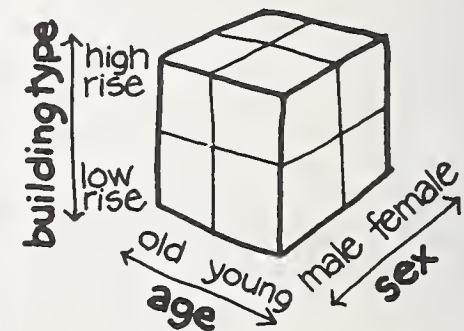



The research approach is based upon the following reasoning. Several variables which might influence room usage will be controlled. For example, the number and quality of seats, room decor, and size of television set may influence how many people use the room. Consequently, to the extent possible the rooms to be observed will be roughly equivalent with regard to these factors. (We could not hope to obtain a sample of identical rooms in real settings.) But many other factors, such as the nearby recreational facilities and the characteristics of particular buildings' residents, may also influence room usage.

Why not try to control these variables?

Let us consider only the attributes of people for the moment. Any approach which would require groups of people to be equated in terms of age, intelligence, economic, social, and cultural backgrounds would fail as it would be hard to find enough people who share that many characteristics. Furthermore, the study cost would be excessive due to the need to study the interactions of so many variables. Instead of attempting to control the many extraneous variables which may affect the results of the study, we hope, by randomly selecting the sample of rooms to be observed, that these variables will also operate randomly. That is, we hypothesize that there is no reason to believe that the variables will operate differently on a "small" room than on a "large" one. Therefore in essence, they can be ignored.

Since the purpose of a research study is to answer a question, experimental conditions are arranged to collect data in a form which produces an answer. Frequently, an experimental design allows two sets of data to be compared, so as to determine whether the measurements obtained in one experimental group are different than those of a comparison group.

In the case described, the goal is to see whether the number of people using small rooms is different from that using large rooms. Statistical procedures are used to help make the needed comparisons, and are especially useful when many variables are being studied simultaneously. On the other hand, the researcher should not forget that while statistical analysis is a useful tool to help make judgments, it is only a means to that end.

Statistical analysis of data may reveal significant differences between compared groups of observations, even though the differences are unimportant from a practical viewpoint. For example, should study results show that significantly more people use the large room than the small one, but the actual numbers are ten and eight, we might judge this difference unimportant from the design decision viewpoint. On the other hand, if we found that on the average, 25 people used the larger room as compared to five for the smaller room, then a statistical analysis of our findings would be superfluous: the importance of the findings is self-evident.

Most research findings are not so clearcut. Instead, differences in response measurements often need to be interpreted. One method used for such interpretations is the **null hypothesis**.

In using the null hypothesis the researcher asks questions in a way that seems contrary to common sense. Even though what is sought is whether there are any differences between the experimental groups (e.g., small vs. large rooms), the research hypothesis statement takes the form that there are no differences between the groups being compared.

This procedure permits the use of powerful statistical methods to evaluate findings by determining whether the results obtained could be expected as a result of **chance** factors. If chance factors can be ruled out (on the basis of some probability, e.g., 99%), then the differences between the scores in the two groups may be attributed to room size.

Tests of the null hypothesis are based on (1) the degree of confidence (confidence level) desired by the experimenter when making a judgment, (2) the actual differences in scores, (3) the number of subjects (and/or observations) included in the study, and (4) the degree of variability of the scores within each group.

### 95 Percent Confidence Limits (after Edwards)

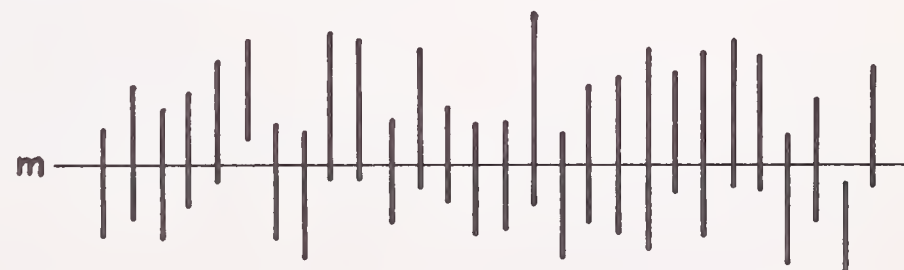

The horizontal line represents the fixed value of the population mean  $m$ . Varying values of the lower confidence limit  $m_1$  and the upper confidence limit  $m_2$ , in successive random samples, are represented by the lower and upper end points, respectively, of the vertical lines. It is assumed that in the long run, 95 percent of the vertical lines will contain the parameter  $m$ .



Statistical estimates can be made as to the likelihood of differences of various magnitudes arising due to chance factors alone. These estimates in turn are based on theoretical distributions—in behavioral research, typically a normal distribution (for theoretical and empirical reasons).

A level of significance is chosen prior to the collection of data in a study. The choice of level reflects a balancing of the potential costs of two possible types of error, termed **errors of the first kind**, and **errors of the second kind**.

An error of the first kind would be, in Wilson's terms: *the fraction which represents the risk the investigator is willing to take of rejecting the hypothesis of irrelevance when it is actually true. That is to say, if a given investigator always used a 5 percent level of significance and always tested variables with no measurable effect, his statistics would cause him to make the mistake once in 20 cases in the long run of ascribing a real effect to variables of no importance (errors). These apparent effects would just be the effects of chance.*<sup>6</sup> By changing the level of significance, e.g., to one percent, the risk of making errors of the first kind may be reduced. On the other hand, this approach increases the likelihood of making errors of the second kind—not rejecting the null hypothesis, when in fact the measures being compared are different as a consequence of the experimental factors being investigated—and not due to irrelevant (chance) factors.

<sup>6</sup> Wilson

To quote Wilson again:

*Choice of Level. The choice of significance level would depend upon the penalties for errors of the first and second kinds and upon the expectation of different sorts of results which prior knowledge suggests. If the rejection of the null hypothesis that the factor in question has negligible effect means that a million dollars is to be spent in building a plant based on the alternative hypothesis that the factor does have a certain effect, the prudent investigator will tend to set the risk level for errors of the first kind at a low value, perhaps toward one in ten thousand or so. On the other hand, it may be that the acceptance of the null hypothesis when it is wrong, an error of the second kind, carries with it a larger penalty. Thus a given process may be encountering serious troubles so that management is clutching at straws in seeking a solution. Under these circumstances it is important to keep low the chance of missing real effects. This can be done by changing the significance level, taking greater risks of thinking there is an effect when there isn't. If neither of these risks can safely be made high, the only solution is to increase the number of observations or to improve the accuracy of each one.*<sup>7</sup>

<sup>7</sup> Wilson

The null hypothesis that the difference in mean scores between two groups has arisen entirely by chance is usually taken to mean that the scores in both groups are drawn from a single normally distributed population of such scores, as opposed to two systematically different populations. This single population of scores has a true population mean, and the two group means are statistical estimates of the population mean. Except by a lucky coincidence, the mean of a sample of modest size, drawn from a particular population, will differ from the population mean somewhat, and will differ from the means of other such samples. Each sample mean contains what is assumed to be a random error; i.e., the difference between the sample mean and the true population mean is an error of estimate, which, for a large group of samples, is normally distributed around an average error of zero.

The rationale for error estimates in general is stated by J. Roebuck as follows:

*The statistics calculated from samples, while correctly descriptive of the samples, are each merely an estimate of population parameters, since not all of the possible measurements are represented. The potential unknown deviation of the sample statistic from the comparable true population parameter is called the sampling error. This unknown error is presumed to be a single estimate of the population of sampling errors that would exist if many samples were obtained, and the statistics calculated for each sample. The single value obtained from the first sampling is thus subject to an uncertainty, which can be concisely expressed as a probability estimate, assuming the population of errors is normally distributed.*<sup>8</sup>

### Approximate Sampling Error

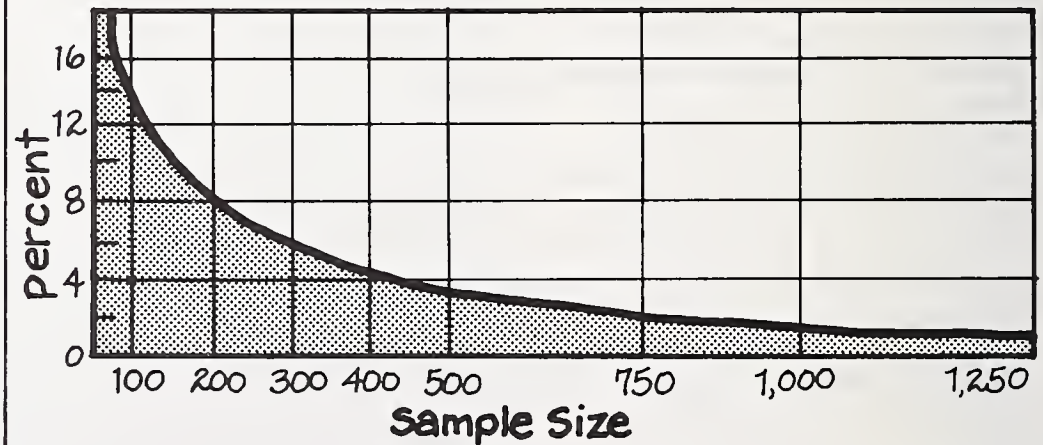

<sup>8</sup> J. A. Roebuck, K. H. E. Kroemer and M. S. Thompson, *Engineering Anthropometry Methods* (New York, 1975).



## Normal Probability Curve

Why judge M/E research findings by comparing a group of measurements with a "normal distribution"?

The research plan described earlier was used to test the null hypothesis, i.e., to determine if differences among groups of scores are attributable to chance factors. In statistical terms, "chance" is the probability of an event—its expected frequency of occurrence among similar events. Frequency of occurrence is sometimes based upon a knowledge of conditions which determine the occurrence of a phenomenon—as in dice throwing or coin tossing. In these instances, given a large number of cases, the outcome of a study (assuming unbiased coins and dice) is not only predictable in terms of chance factors, but describable by a simple mathematical formulation known as binomial expansion, which, when plotted, is roughly in the form of a normal probability curve. The normal distribution (probability) curve is a symmetrical bell-shaped curve with most measurements bunched up near the middle and tapering off at the sides. The normal curve is very useful when one compares observed distributions of data with distributions expected by chance—i.e., when tests of the null hypothesis are valid. (Comparisons are made of the "areas" under the normal curve.) Fortunately, many behavioral research factors are distributed among the general population in accordance with a normal distribution.

The standard deviation is a direct measure of the variation of individual measurements organized around the average value. It determines the width of the normal curve.

### The Normal Law of Error

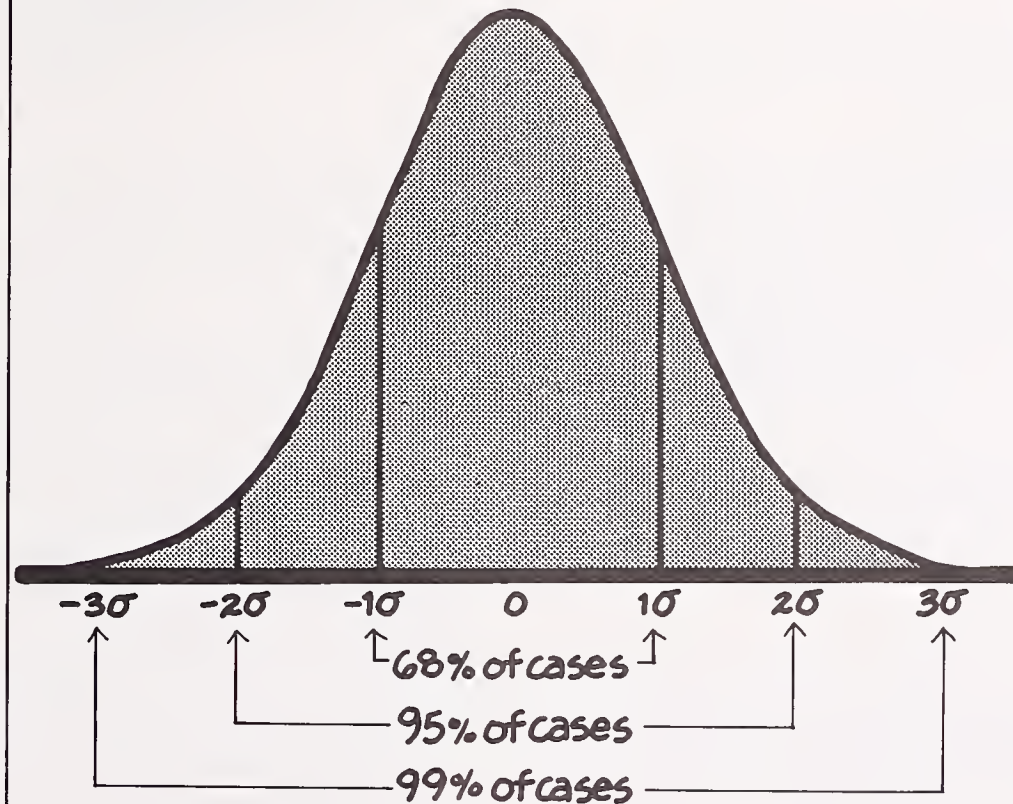

$\sigma$  = Standard Deviation

As W. Youden indicates:

...if we drew a vertical line through the highest point of a (normal) curve, the curve would be symmetrical about it. The vertical line or high point of the curve represents the value for the average of the data. It is customary to use this vertical line as a reference point for marking off multiples of the standard deviation to the right and to the left. You will see that when we have proceeded as much as three standard deviations on either side of the center line, the curve has dropped to about one percent of its height at the center... Ordinates erected at plus (and minus) two standard deviations include approximately 95 percent of the area. Similarly ordinates at 2.57 standard deviations enclose 99 percent of the area.<sup>9</sup>

In the room size example, let us assume a confidence level of 99%. We then want to find out if small and large rooms typically are occupied by the same number of people. In the proposed study the total number of observations is considerable for each size room, 10 (rooms) x 6 (time periods) x 10 (replications) = 600. Let us examine two subsamples (10 x 1 x 10), and assume they are representative of all data.

The simplest (and ideal) case consists of data which would not even require statistical analysis since the results would be relatively self-evident, e.g., average occupancy "scores" of 20 (large) and 5 (small) or 10 (large) and 10 (small).

<sup>9</sup> W. J. Youden, *Risk, Choice and Prediction* (Belmont, Calif., 1974).

What is meant by an average score?

An average score is a measure of "central tendency" (that is, a typical value in some sense) in that it gives a concise description of a group of scores. It also enables us to compare the scores of two or more groups in terms of typical performance. Three average scores are in common use—the **median**, the **mode**, and the arithmetic mean, which is usually used as the average score.

Whereas an average score summarizes one major characteristic of a group of scores, it does not describe their variability, i.e., the scatter of the individual scores around the measure of central tendency. Finding the variability of groups of scores is critical in deciding whether compared scores are different from one another, because it asks how typical are the average scores being compared. For example, in the ideal case, the "average" score would be a grouping of identical scores, i.e., every measure would be the same.

In general, the narrower the range of scores, the more typical the average score. The wider the distribution of scores, the less justification we have in using an average score with any degree of confidence. The reason for this is the concern that we are grouping measures (observations) of things or events which may be very imprecise, i.e., large experimental errors are included in the data.

## Measures of Central Tendency—Distributions (After Arkin and Colton)

Mean (Arithmetic)	Mode	Median
<b>Definition:</b> The average score; the sum of scores divided by the number of cases	Most frequent or common value	Value of the middle item when items are arranged according to size—e.g. if item total is 21, then value of 11th item is median.
<b>Characteristics:</b> <ul style="list-style-type: none"> <li>• A calculated average</li> <li>• Every case has a determinate value</li> <li>• The sum of deviations about the mean is zero</li> </ul>	<ul style="list-style-type: none"> <li>• Independent of extreme items</li> <li>• Average position</li> </ul>	<ul style="list-style-type: none"> <li>• Average position affected by number of items, not by the size of extreme values</li> </ul>
<b>Advantages:</b> <ul style="list-style-type: none"> <li>• Most commonly used average</li> <li>• Most easily understood</li> <li>• Computation is relatively simple</li> <li>• Total values and number of values sufficient for computation</li> <li>• It may be treated algebraically</li> </ul>	<ul style="list-style-type: none"> <li>• Most typical and therefore most descriptive value</li> <li>• Simple to approximate by observation where there are a small number of cases</li> <li>• Not necessary to arrange or compute values</li> </ul>	<ul style="list-style-type: none"> <li>• Easily calculated</li> <li>• Not distorted by extreme values</li> <li>• May be calculated when distributions are "open ended", i.e. where items are grouped as "over" and "under" values</li> </ul>
<b>Disadvantages:</b> <ul style="list-style-type: none"> <li>• Value may be distorted by extreme values and therefore may not be typical</li> </ul>	<ul style="list-style-type: none"> <li>• Can be approximated only when data are limited</li> <li>• Of limited usefulness when a large number of values is not available</li> <li>• Mode may not exist (values not repeated)</li> <li>• Cannot be manipulated algebraically</li> </ul>	<ul style="list-style-type: none"> <li>• Relatively unfamiliar</li> <li>• Items must be arranged in terms of size</li> <li>• Cannot be manipulated algebraically</li> </ul>



Our task is to compare the usage of small and large rooms. Let us assume that the appropriate measure is the room's peak occupancy. A data point would therefore be the highest "score" among the observations made of a particular room on a given day. The total data set consists of 200 observations, 100 each for small and large rooms (10 rooms, 10 observations). The comparison will be made by statistically comparing the "averages" of the peak scores. However, if the comparisons are to be meaningful, we must first find out how typical the average scores are—that is, to what extent the scores in each group differ from one another. Differences within each group take two forms. In one case, it is a problem of reliability—i.e., the extent to which the peak number of people occupying a room is the same on the 10 occasions when observations are made. The other way that scores within the group may be expected to vary is with respect to the 10 different rooms which constitute the study sample. For example, the rooms in some buildings might be used intensively and those in others might not be used at all.

The need to look at the variability of a group of scores is a major factor in determining the sample size in a study. The research question becomes one of the amount of data required to make a decision about whether the two groups being compared have different requirements. We must trade off between collecting a minimal amount of data (with the attendant risk of not reaching the correct decision about the "reality" of the

## In General, More Data Means More Reliability

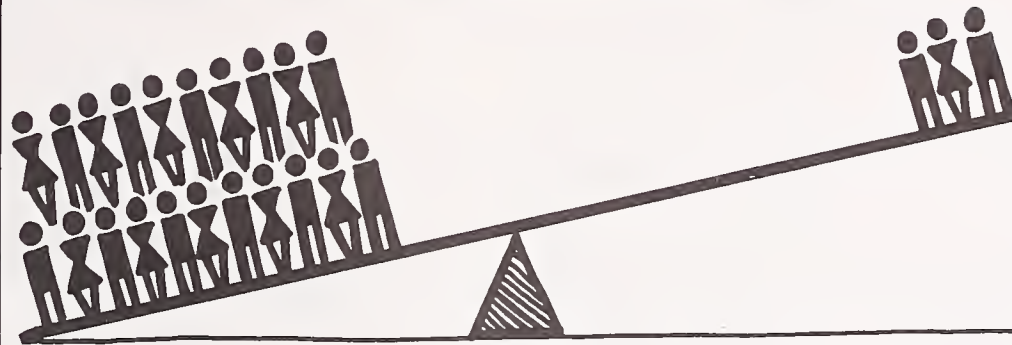

differences found) and collecting a great deal of data (which increases time and money costs but improves the chances of making a correct decision).

For example, in our study, if we have a minimum number of rooms in each group (e.g., 10), one may need a 5-point difference (3,8) in ratings between groups in order to conclude that room size differences are necessary to account for the findings. On the other hand, assuming 100 rooms in each group, then a 3-point difference in scores might be statistically significant, that is, a difference not attributable to chance factors. (One purpose of the pilot study is to estimate the range of variation among measures.) The fact that differences are statistically significant should not dictate the design decision, however. If the actual peak occupancy values were 20 for small rooms and 25 for large rooms, the absolute difference—i.e., 5, might not justify the amount of space required for a large room.

If occupancy rates for large rooms were found to be significantly greater than those for smaller rooms, how are these findings to be interpreted?

In scientific research, the goal is to be able to make cause-effect statements. Can we reasonably say that the number of people occupying a room is caused by the size of that room? No, too many other factors are not accounted for, i.e., the random variables (decor, seats, quality of television, etc.).

What can be said is that room size and occupancy are highly and positively correlated with one another. The two variables vary systematically in the same direction. In contrast, occupancy rates and noise levels are probably highly correlated also, but the correlation in this case would be negative, i.e., the greater the noise level, the fewer the people in the room (unless of course, the source of the noise is the people).

## Conclusion

It soon becomes apparent that the environment where people perform activities is extremely complex. Social, cultural, and personal factors come into play and interact with building and environmental features in all their complexity. Consequently, simple cause-effect relationships between environmental and behavioral variables are rare. Instead, it is more realistic to assume that environmental features influence the activities of people to differing degrees, depending on circumstances.

The goal of M/E research is to better understand these variables and to determine the extent to which behavior is associated (correlates) with design feature variables.

## Correlational Data

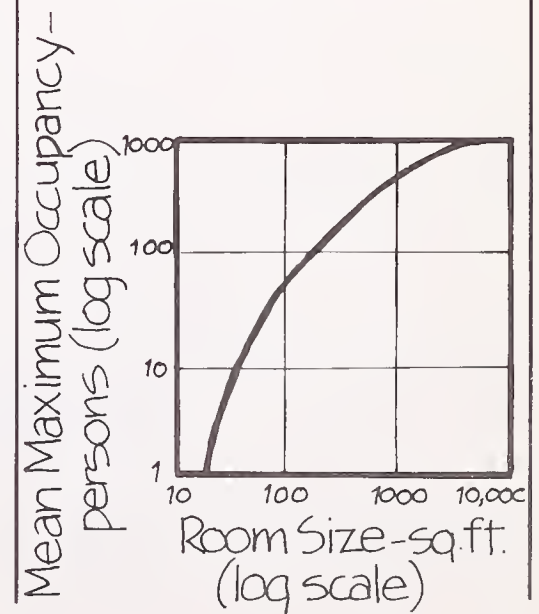

# Common Vocabulary Needed

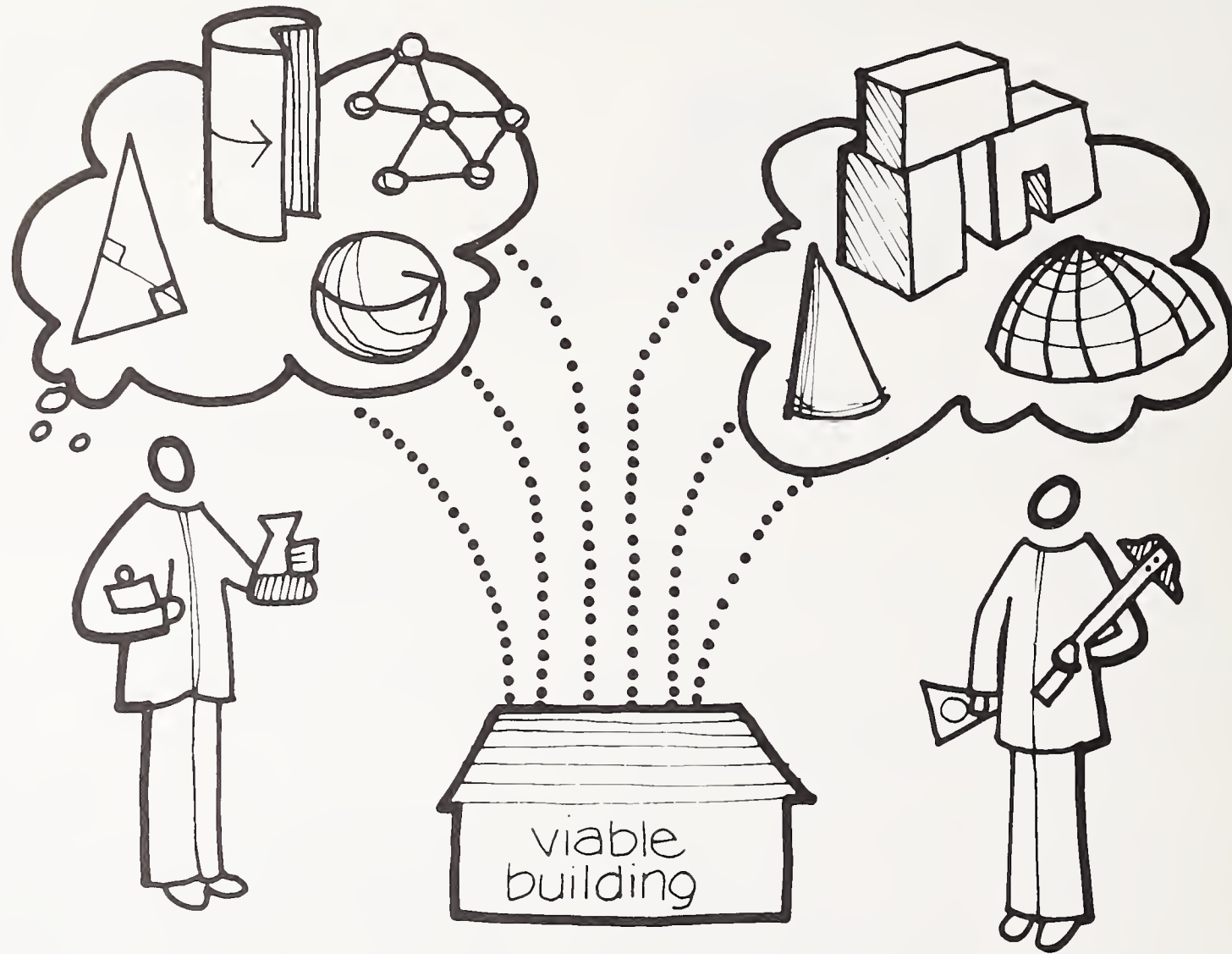

Social Scientist

architect

Each needs to understand the vocabulary of the other.



# Glossary

## Absolute Threshold

The minimum amount of physical stimulus that is needed to produce a sensation; frequently interpreted as responding to half (50%) of the stimuli presented (psychophysics).

## Achromatic

Lacking in hue and saturation. Achromatic colors vary only in brightness, from black to white, e.g., various shade of gray.

## Acoustics

1. Acoustics is the science of sound, including its production, transmission, and effects.
2. The acoustics of a room are those qualities that together determine its character with respect to distinct hearing.

## Activity

Anything an organism does or that happens within an organism; anything requiring expenditure of energy by an organism.

## Adaptation

In general, adjustment to environmental conditions. Sensory adaptation involves a change in the characteristics of experience as a result of prior experience. In design, becoming less sensitive to environmental attributes after prolonged experience.

## Additive Mixture

A color formed by the combination of light of different colors, for example, the combination of blue and red light sources to produce violet.

## Amplitude

The amount or value of a wave or a fluctuating magnitude or variable.

## Analytic Approach

One that assumes that a complex process can be understood by breaking it into its components, and that the complex can best be improved by improving its parts.

## Analytical Survey

A survey designed to clarify associations and provide explanations. It presupposes a theoretical framework suggesting causality among

variables, as contrasted with a descriptive survey, which enumerates but does not ask "why."

## Anechoic Chamber

One whose surfaces absorb effectively all the sound incident thereon, affording essentially conditions where the effects of boundaries are negligible. Space where hearing research is often conducted.

## Anthropometry

The science of measuring the human body and its parts and functional capacities.

## Architecture

1. The profession of designing buildings, open areas, communities, etc., usually with some regard to aesthetic effect.
2. The result or product of architectural work, as a building.
3. The character or style of a building.

## Arrival Distance

The distance that a newcomer uses to separate himself from a person already occupying a space.

## Articulation Index (AI)

A numerically calculated measure of the intelligibility of transmitted or processed speech. It takes into account the limitations of the transmission path and the background noise.

## Articulation Test

A test for accuracy in pronouncing speech sounds, both singly and in connected speech.

## Attenuation

A reduction in the degree or amount of anything. For example, the attenuation of noise produced by a barrier.

## Audiogram

A graph showing hearing thresholds in terms of frequency and intensity.

## Audiometer

An instrument for measuring hearing sensitivity.

## Autonomic Response

Response by a division of the nervous system serving the endocrine glands and smooth muscles.

## A Common Set of Anthropometric Instruments

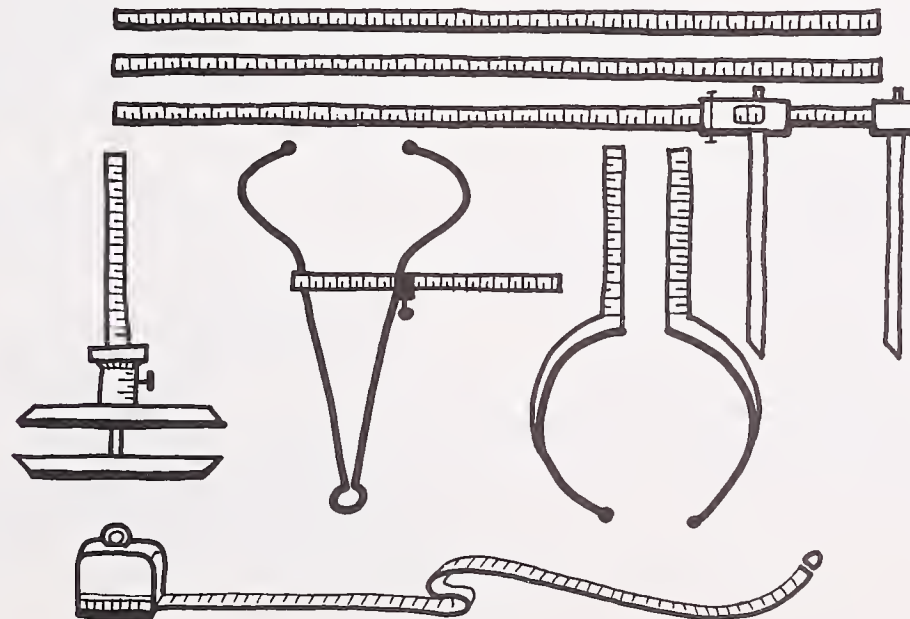

**Average**

Measure of central tendency. Three average scores are in common use—median, mode, and arithmetic mean.

**A-Weighted Sound Pressure Level (A-Level,  $L^a$ )**

A measurement of sound pressure level in which the sound has been filtered or weighted to quantitatively reduce the effects of the high and low frequency components. It was designed to approximate the response of the human ear to sound. A-level is measured in decibels with a standard sound level meter which contains the weighting network for "A."

**Background Noise**

The total of all noise in a system or situation, independent of the presence of the desired signal.

**Behavior Setting**

In ecological psychology, the bounded units (towns, schools, meetings, etc.) within which the behavior studied occurs. (Barker)

**Behavioral Mechanisms**

Affective, gross motor, manipulation, verbal, and thinking mechanisms used in studying behavior settings.

**Bi-modal**

Refers to a frequency distribution with two peaks.

**Bounded Units**

The behavior settings in which ecological behavior occurs. They are: 1) self-generated 2) with specific time-space loci 3) with unbroken boundaries which separate them from differing external patterns. (Barker)

**Brightness**

The subjective impression of the total amount of light reaching the eye from a visual stimulus.

**Case Study**

A collection of all relevant evidence—social, psychological, physiological, biographical, environmental, vocational—to illustrate a single activity, individual, or a single social unit such as a family.

**Cerebrum**

In man, the largest portion of the brain occupying the entire upper part of the cranium and consisting of the right and left hemispheres.

**Chance**

In research, something that happens unpredictably without discernable human intention or observable cause.

**Chroma**

Synonym for color saturation.

**Chroma Scale**

A scale ranging from neutral (gray, black, or white) to the most saturated or nongray color. In the Munsell surface-color solid, the chroma scale is represented by distance from the central axis.

**Chromaticity**

The quality of a color stimulus determined by its dominant wavelength and its purity.

**Chronocyclography**

A photographic method of recording movements. A series of pictures of the sequence of movements is obtained by several exposures at known intervals on one and the same photograph.

**Cine Camera**

A camera used in interval photography with intervals that can be set from 2 exposures/second to 1 exposure/54 seconds.

**Class Interval**

In statistics, a small section of a scale, according to which frequency distributions are grouped, e.g., heights, weights.

**Clo Value**

A numerical value given to clothing in thermal comfort computations (0 = no clothing).

**Closed Message Set**

Used in speech intelligibility studies in which the subject knows all of the possible messages.

**Cochlea**

A coiled structure of the inner ear which contains the receptors essential for hearing.

**Coding**

1. (Statistics). The process of transforming a set of scores into a more convenient set. 2. (Information theory). The transformation of messages into signals.

**Cognitive Map**

1. The ability to reorder and reconstruct parts of our experience to provide a complete picture of a situation 2. The description of a place in terms of its location and psychological influences, from the standpoint of an individual.

**Color**

Visual sensation determined by the interaction of wavelength, intensity, and mixture of wavelengths of light.

**Color Rendering**

The effect of a light source on the color appearance of objects as compared with appearance under a standard light source.

**Colorimeter**

A device for measuring colors and specifying them in numerical or symbolic terms.

**Comparison**

The member of a stimulus pair which is varied by the subject until it matches the standard, or other stimulus in the pair. Also, the pair member upon which a judgment is made relative to the standard.

**Conditioned Reflex**

A reflex based on previous experience rather than inherited structure, such as dogs salivating at the sound of a bell (Pavlov).

**Cone**

One of the cone-shaped cells of the retina used in color vision.

**Confederate**

A person working with an experimenter as a covert participant in a research study.

**Confidence Level**

The probability of the truth of a statement that a parametric value will be included in a confidence interval.

**Constancy Phenomena**

The tendency for brightness, color, size, or shape to remain relatively constant despite marked changes in stimulation.

**Control Group**

Similar in all respects to an experimental group, but not subject to changes in experimental conditions.

**Control Setting**

In laboratory research, control of the stimulus.

**Control Variables**

Those which are unchanged in an experiment, as distinguished from independent variables.



## Correlation

A relationship between variables such that changes in one are accompanied by changes in the other, either positively (as when weight tends to increase with height) or negatively.

## Correlational Data

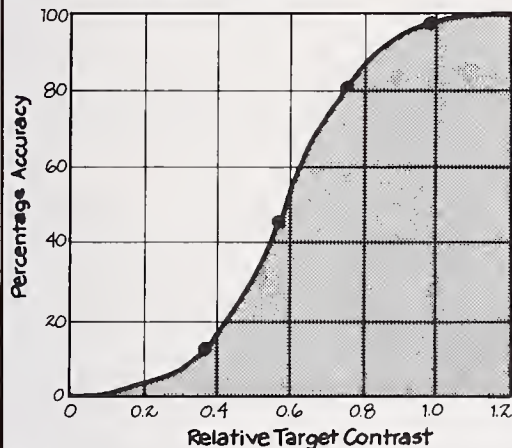

Sample accuracy curve: response probability data fitted by a cumulative curve.

## Critical Distance

The flight distance, or point at which encroachment into an animal's territory by another animal produces flight or attack. (Also: flight distance.)

## Critical Flicker Frequency (CFF)

The frequency of light flashes necessary to produce an uninterrupted experience of brightness, i.e., without flicker.

## Cross-Sectional Survey

A type of survey in which the data result from a time-ordered series of questions asked of a sample of a pre-defined population of subjects.

## Cutaneous

Pertaining to the skin.

## Dark Adaptation

The process by which the daylight cone vision is taken over by nighttime rod vision. Eyes are considerably more sensitive after dark adaptation.

## Data

Information obtained from a scientific study, or by other techniques.

## Data Analysis

Analysis of information obtained from a scientific study, or other techniques.

## dB

A quantity in decibels which can be read from a standard sound level meter. The A-weighting network is designed to approximate the sensitivity of the human ear at moderate sound levels.

## Decibel (dB)

The unit of sound intensity.

## Deductive

The mode of reasoning that starts with premises or propositions and attempts to derive valid conclusions therefrom.

## Defensible Space

Concept developed by Oscar Newman; involves idea that neighborhood security can be increased by specific architectural design features that allow surveillance by residents as a part of their everyday activities.

## Dependent Variable

The variable whose value changes as a result of the experimenter's changes in another variable, the *independent variable*.

## Descriptive Survey

One designed to answer questions about the distribution of some datum (e.g., income) in a population or among subgroups of a population.

## Diary

A method used in M/E studies where people maintain records of activities performed. Duration times and frequencies are often critical.

## Dichotomous items

Survey questions which require the subject to make a forced choice between two explicit alternatives.

## Difference Limen (threshold DL)

The smallest change in a physical variable that is detected by an observer; frequently interpreted as responsive to 50% of the stimuli presented (psychophysics).

## Disability Glare

Glare resulting in reduced visual performance and visibility.

## Discomfort Glare

Glare which results in a feeling of annoyance. It does not necessarily interfere with visual performance or visibility.

## Discontinuous Photography

A technique for recording the behavior of subjects at discrete instants of time of interest to the researcher.

## Display

Any means of presenting information to a person.

## Distance Relationships Among People (Hall)

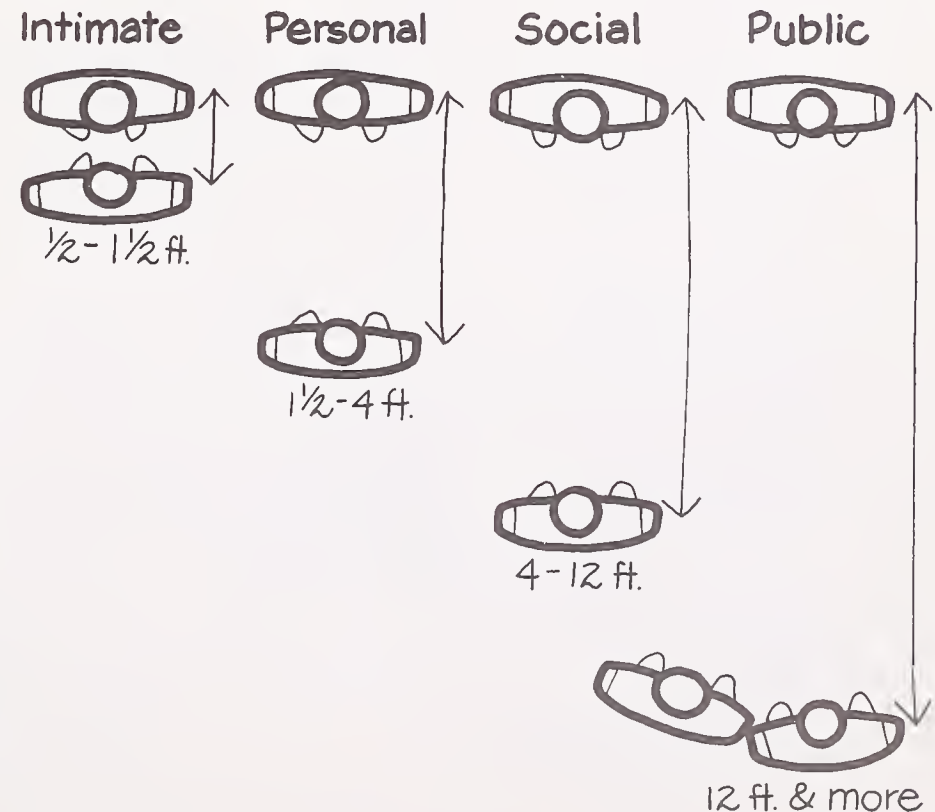

**Distance After Departure**

The distance which birds (or other organisms) will keep between each other after intermediate birds have left.

**Drift**

Movement of buildings such as high rise structures during storm conditions when high velocity winds are present.

**Ecological Psychology**

The study of organisms in reference to their physical environment, especially their responses to stimuli which are environmental.

**Effective Temperature**

A combination of air temperature, wind velocity, and relative humidity used in investigations designed to establish and define a comfort zone for human subjects.

**Electrocardiogram (EKG)**

Graphic records produced by an electrocardiograph, a galvanometer device that detects and records the minute differences in potential between different parts of the body caused by heart action.

**Electroencephalogram (EEG)**

A graphic record of the wavelike changes in the electric potential observed when electrodes are placed on the surface of the head.

**Electromyography (EMG)**

The graphic recording of electrical activity or currents in a muscle.

**Elements**

Parts or constituents of a whole, especially those that cannot be reduced to simpler units.

**Equal Loudness Contours**

A curve which shows sound pressure levels for different frequencies, heard as having a fixed loudness level.

**Ergograph**

An instrument for studying fatigue in a restricted muscle group.

**Ergonomics**

The scientific study of the relationships between men and machines, particularly the psychological, biological, and cultural, with the purpose of adapting machines and jobs to meet the needs of men and of choosing suitable persons for particular jobs or machines.

**Errors of the First Kind**

If as the result of a statistical test, a statistical hypothesis is rejected when it should be accepted.

**Errors of the Second Kind**

If as the result of a test, a statistical hypothesis is accepted when it is false, i.e., when it should have been rejected.

**Experiment**

Controlled arrangement and manipulation of conditions in order to systematically observe particular phenomena with the intention of defining the influences and relationships which affect those phenomena.

**Experimental Design**

Plan of an experiment structured to answer specific experimental questions. Design usually specifies: 1) choice of variables; 2) choice of subjects, species, age, sex, etc.; 3) apparatus used or stimulus presentation and response recording; 4) experimental procedure; 5) type of analysis of results.

**Experimental Psychology**

1. The investigation of psychological phenomena by experimental methods.  
2. The methods and the results obtained by experiment, systematically set forth (often arbitrarily limited to the psychology of the laboratory).

**Experimental Setting**

The characteristics of a space where a study is being performed.

**Experimental Subjects**

Organisms to whom stimuli are applied for the purpose of evoking responses; or, more generally, the organisms whose reactions are observed.

**Feedback**

Knowledge of the results of an action; perception of a state of the body or of the environment.

**Field Study**

Collection of data outside the laboratory, library, or clinic; the study of organisms in their usual habitats.

**Figure-Ground**

The principle that all perception and even awareness is fundamentally patterned into two parts or aspects that mutually influence each other: a) the *figure*, which has good contour, unity, and is perceived as being separate from the ground, and b) the *ground* which is typically relatively homogeneous and whose parts are not clearly patterned.

**Film Color**

Hue seen as such without reference to its being a surface or other characteristic of an object.

**Filter Question**

A question, primarily factual in nature, which may be used in public opinion research to enable the interviewer to determine the extent of knowledge possessed by the respondent about the topic under study.

**Fixed-Feature Space**

Features of buildings that are not movable, e.g., windows, walls.

**Flight Distance**

A critical distance at which point further encroachment on an animal's territory by another animal causes flight or attack.

**Focused Interview**

An interview which uses an interview guide with a list of objectives and suggested questions. Using this technique, an interviewer can explore new topics as they are introduced and can follow up in detail when this appears to be a useful approach.

**Fovea**

Central part of the eye used for daytime vision.

**Free Association**

1. An unrestricted, random flow of words or ideas. 2. In psychoanalysis, a method employed in which the patient says whatever comes into his mind and speaks freely.

**Frequency**

1. The number of cycles per unit time in a periodic vibration. 2. The number of times a given event occurs; especially, the number of times the several values of a variable are found.

**Galvanic Skin Response (GSR)**

The changes in the electrical resistance of the skin measured by a galvanometer. It is used as an indicator of emotional arousal and tension.



**Gaming**

A research technique in which subjects' needs, activity patterns, preferences, etc., are determined by how they play certain games.

**Gestalt**

A configuration or figure whose integration sometimes differs from the totality obtained by summing the parts.

**Glare**

See *disability glare*, *discomfort glare*.

**Gradient**

Any regular change in a magnitude which slopes from high to low or vice versa.

**Hard Architecture**

A phrase used by R. Sommer to describe design features which hinder interaction and lead to feelings of isolation.

**Hawthorne Studies**

A pioneering series of studies started in 1927 and continuing into the early 1930's done at the Western Electric Company by Elton May, F. J. Roethlisberger, W. J. Dickson, and their associates. The studies showed the importance of social variables and demonstrated that work efficiency was not just the product of physical or economic conditions.

**Heel Impact Test**

A test to determine whether there is a vibration problem in a building. A 170-lb. (77 kg) man stands on his toes at the geometric center of a floor, then drops suddenly to his heels, while a subject standing near him gives subjective impressions of the vibration experienced.

**Hertz (Hz)**

Cycles per second; a specification of energy in waves, commonly used in sensory research for auditory stimuli.

**Hodometer**

An instrument used to measure foot movement activity.

**Hollistic**

A principle which holds that an organism is not equal to the sum of its parts and must be considered as a whole.

**Home Range**

A series of linkages and settings traversed and occupied by an individual in his normal activities.

**Homogeneous**

Of the same or a similar kind or nature.

**Hue**

The perceived dimension of color which corresponds to the wavelength of light which stimulates the retina. Hues may be grouped as reds, yellows, greens, and blues with their intermediates, the oranges, yellow-greens, blue-greens, and purples.

**Hue Circle**

Scale for constant visual hues represented by symmetrical color circle.

**Human Factors**

A discipline concerned with the optimization of the human component in man/machine systems. (Also referred to as human engineering or human factors engineering).

**Hypnosis**

An artificially induced sleep-like state characterized by increased suggestibility, decreased initiative and will to act on one's own, recollection of events not remembered in the normal state, and often amnesia for that which occurred while hypnotized.

**Hypothesis**

1. An assumption; a guess. 2. A tentative statement to be proven or disproven by evidence.

**Illuminometer**

An instrument which measures luminance, the objective correlate for brightness.

**Illusion-Visual**

An incorrect visual perception usually affecting spatial relations.

### Illusion- Perceived Size Change

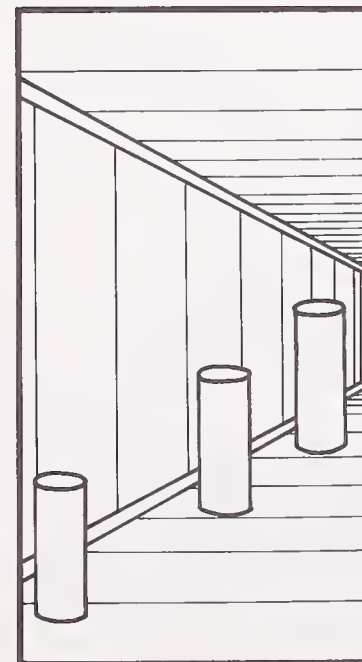
**Imageability**

Characteristics of the environment which lend themselves to forming a vivid image in the person experiencing it.

**Incident Light**

Light shining on a specified object.

**Independent Variable**

1. A variable that can be observed and assessed as a determinant of behavior. 2. The variable that is altered independently of any other variable, usually by the experimenter.

**Individual Differences**

Any psychological characteristic, quality, or trait by which an individual may be distinguished from others. Also, the differences characteristic of individuals in different categories.

**Induction**

The logical process by which principles or rules are derived from observed facts.

**Industrial Design**

A discipline concerned with improving the performance of products through better design.

**Innate**

Present in the individual at birth.

**Instructional Set**

A preparatory adjustment or readiness for a particular kind of action or experience, as a result of instructions.

**Intensity**

1. (Physics) the magnitude of energy or force per given unit of space and/or time, as of a physical stimulus. 2. The strength of any behavior, emotion, or motivation.

### Interval Photography

A technique for recording behavior on film during selected intervals of time. Interval photography is suitable for use with continuous sequences of events where it is sufficient to record only a sample of the process.

### Interval Scale

A type of scale which does not have an absolute zero point but possesses equal intervals and differences.

### Intimate Distance

The distance maintained between two people discussing matters of a personal nature.

### Invisible Bubble

The space around a person which, when violated, is perceived as an intrusion of one's privacy.

### Just Noticeable Difference (JND)

The minimum amount of difference detectable between two stimuli being compared.

### Laboratory Study

A study performed in a place set aside for scientific research, especially, but not exclusively, for experiment. (Laboratory studies contrast with field studies and library research).

### Landolt Ring

An incomplete circle having a gap of varying size, used in the determination of visual acuity.

### Learning Approach

A viewpoint which emphasizes the role of experience in behavior research.

### Legibility

The quality of a visual symbol, usually of a printed or written symbol, that makes it easy to read or to distinguish from other symbols.

### Level of Significance

Statistical term indicating the degree of confidence we can have that the result was not caused by chance alone. The level of significance is expressed as the number of times in 100 that the given result could be expected to occur by chance alone. Thus a level of "5%" means that the result would be expected by chance alone only 5 times in 100.

### Life Space (Lewin)

The entire set of phenomena in the environment and in the organism itself which influences present behavior or the possibility of behavior. Emphasis is placed on the interaction between the organism and its environment in an organized, unified field.

### Lightness

An attribute of an object color by means of which it can be placed in the series between black and white.

### Lightness Scale

A scale ranging from white to black with shades of gray between. The lightness of a chromatic (nongray) color determines the gray to which it is equivalent on the lightness scale.

### Landolt Ring

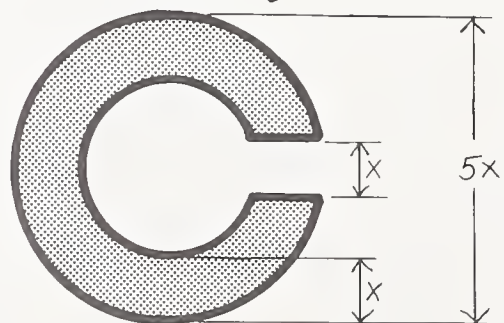

Dimensions of Landolt broken circle

### Life Space

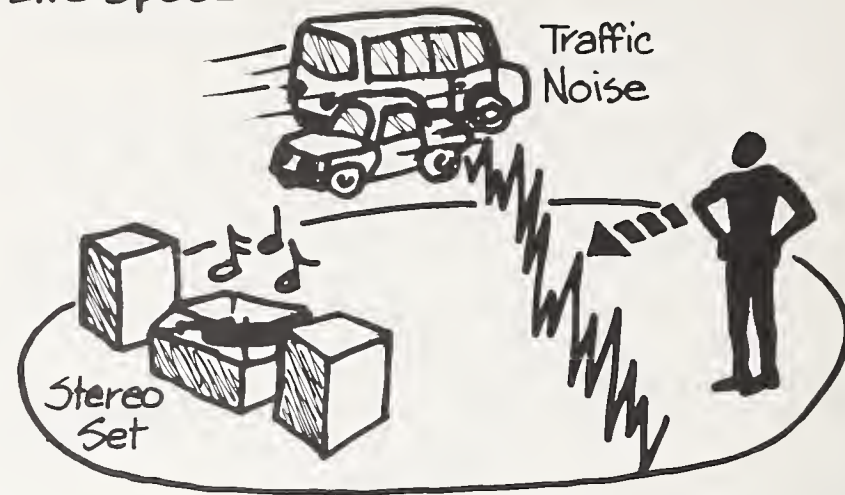

♫ Attraction of Activity  
Psychological Environment

◀ Desire to Listen to Music  
Barrier to be Overcome

### Loudness

The heard attribute of an auditory stimulus which corresponds to the physical attribute of intensity.

### Luminance

Light energy transmitted, reflected, or emitted from a source; the actual strength of light in the whole of the space involved. It is the objective correlate of the subjective variable of brightness.

### Macro

A combining form meaning "large," or "extended," in contrast to micro.

### Mail Survey

A method of data collection in which self-administered questionnaires are mailed to subjects; typically, the response rate is low.

### Masking

Interference with the perception of a stimulus caused by the simultaneous occurrence of another stimulus. In hearing, for example, a tone becomes harder to hear if it is accompanied by *white noise*. The noise is said to "mask" the tone.

### Maslow's Need Hierarchy

A postulated hierarchy or order in which the individual must satisfy physiological needs first, followed by needs for safety, love, esteem, and self-actualization.

### Matched Group

(Experimental research) one of the groups used in an experiment which is made equivalent in as many respects as possible to ensure experimental control.



**Mean**

The average score; the sum of the scores divided by the number of cases.

**Median**

The middlemost score in a series arranged in rank order.

**Metabolic Rate**

The rate at which certain vital physical and chemical and physiological reactions occur within an organism.

**Metamerism**

The phenomenon of color stimuli having different spectrophotometric characteristics but appearing identical under favorable conditions of comparison.

**Method of Average Error**

One of three classic psychophysical procedures for measuring either the differential or the absolute threshold. The observer controls the independent stimulus dimension and sets it according to experimental instructions, e.g., "just audible," "just noticeably different," etc. Also known as the method of adjustment.

**Method of Constant Stimuli**

(Fechner) a psychophysical technique used for determining absolute and differential thresholds by requiring the subject to compare various stimuli drawn from a preselected sample with a standard, or to state when a given stimulus is noticed.

**Method of Limits**

A psychophysical technique used for determining the smallest difference in a stimulus that can be discriminated by a subject. The distance between two nondiscriminable stimuli is increased, or the distance between two discriminable stimuli is decreased and the average point at

which the former is first discerned or the latter not discerned is recorded.

**Methodology**

1. The systematic and logical study and formulation of the principles and methods used in research. 2. The procedures actually used in a particular investigation.

**Micro**

A combining form meaning "small," "very small," or "diminished" in contrast to macro.

**Milieu**

A surround which provides a context for a setting and the behaviors which occur.

**Mode**

In statistics, the most frequent score of a series.

**Model**

A system of principles or hypotheses or a representation which is postulated to explain relationships in the data and is usually presented in mathematical terms.

**Muller-Lyer Illusion**

The distorted perception of length when a line has arrowheads, or reversed arrowheads. The former looks shorter, the latter longer than the line without arrowheads.

**Multiple Choice Question**

A question in which the subject is given several responses from which to choose.

**Multiple Criterion Technique**

A research technique in which the subject adjusts one parameter at a time out of a set of previously identified variables relevant to the behavior being studied.

**Multivariate**

In statistics, a technique of analysis designed to assess the existence and size of effect of many variables acting simultaneously. Also, characterizing a measure that reflects several variables.

**Munsell System**

A system for ordering surface colors by specifying hue (color), value (lightness), and chroma (saturation).

**Nativists**

A group of perceptual psychologists who place emphasis on the inherited factors determining perception rather than on experience.

**Needs**

1. Conditions of lacking, wanting, or requiring things which if present would benefit the organism by facilitating behavior or satisfying a tension. 2. Tensions induced in the organism by a lack, either internal or external.

**Noise**

1. The sensory effect of irregular sound waves; a sound that lacks tone, that is composed of conflicting pitches. 2. Undesired sound. 3. Anything that introduces extraneous

variability into a communication process, or that reduces the information.

**Noise Criteria (NC) Curves**

Any of several versions (SC, NC, NCA, PNC) of criteria used for rating the acceptability of continuous indoor noise levels, such as produced by air-handling systems.

**Nominal Scale**

A scale in which numbers are assigned to events or event classes for identification and with no reference to any property of the event or class. Thus, the number does not represent any dimension of the event or class.

**Nonsense Syllable**

A syllable, usually of three letters (consonant-vowel-consonant), which has no meaning. Sometimes considered useful in eliminating the influence of meaning on memorizing, but the evidence is that people memorize nonsense by giving it a meaning of their own.

**Normal Distribution Curve**

Symmetrical bell-shaped frequency curve with most of the measurements near the middle and tapering off at the sides.

THE  
NORMAL  
LAW OF ERROR  
STANDS OUT IN THE  
EXPERIENCE OF MANKIND  
AS ONE OF THE BROADEST  
GENERALIZATIONS OF NATURAL  
PHILOSOPHY • IT SERVES AS THE  
GUIDING INSTRUMENT IN RESEARCHES  
IN THE PHYSICAL AND SOCIAL SCIENCES AND  
IN MEDICINE, AGRICULTURE AND ENGINEERING •  
IT IS AN INDISPENSABLE TOOL FOR THE ANALYSIS AND THE  
INTERPRETATION OF THE BASIC DATA OBTAINED BY OBSERVATION AND EXPERIMENT

(after Youden)

**Noy**

A unit used in the calculation of perceived noise levels.

**Null Hypothesis**

(Statistics) a hypothesis stating that an experimental effect does not exist, that the mean of a group is equal to zero, or that there is no difference between means.

**Object Constancy**

The fact that perceptual objects retain a certain standard appearance, in considerable independence of surrounding stimuli and also of the component stimuli making up the perceptual pattern.

**Objective**

Not depending on the judgment or accuracy of the individual observer; free from personal bias.

**Observational Techniques**

Techniques and procedures for assisting the observer to make more complete and accurate observations. Included are mechanical aids to observation, charts and checklists for prompt and inclusive records, motion picture photography and sound recording, and special training of the observer.

**Octave Band**

A frequency interval including those frequencies between two tones whose frequencies are related by a ratio of 1:2.

**Olfactometer**

An instrument that regulates the degree of concentration of a substance used in odor research.

**Open-Ended Question**

Any question which allows the person answering flexibility of form and substance in his response.

**Open Message Set**

A set of messages, all of which are unknown to a listener. These message units are presented under adverse conditions of communication in order to measure probability of reception.

**Operational Definition**

Scientific facts and concepts are identified by the concrete operations through which they were produced.

**Ordinal Scale**

A type of scale which arranges objects with reference to their magnitude and assigns numbers accordingly—first, second, third, etc. It does not possess equal intervals or an absolute zero point.

**Organism (O)**

Any living entity which has the potential to maintain itself and exist independently as a self-contained system with functions such as respiration, digestion, etc. This includes all plants and animals.

**Osmoscope**

An instrument used in determining odor thresholds.

**Paired Comparisons**

The pairing of stimuli in all possible combinations, a technique often used in psychophysics and social psychology. The subject is asked to make comparisons for each pair formed.

**Panel Study**

A study in which one sample of people is interviewed recurrently over a long period of time to investigate the processes of response change, usually in reference to the same variable.

**Parallax**

The apparent movement of objects when the viewpoint is shifted laterally in the field of vision.

**Parametric**

A research strategy which emphasizes definition and understanding of basic variables usually in a laboratory setting.

**Participant Observer**

An observer who gathers observation data while taking part in a group or an activity being observed.

**Passive Observer**

An observer who gathers data by not intruding into the observed situation nor altering the situation in any way.

**Peak Noise**

The maximum instantaneous sound pressure (a) for a transient or impulsive sound of short duration in time, or (b) in a specified time interval for a sound of long duration.

**Pedometer**

An instrument which measures distance walked by recording the number of steps taken.

**Perceived Noisiness (PN)**

The level in dB assigned to noise by means of a calculation procedure that is based on an approximation to subjective evaluations of "noisiness."

**Perception**

The process of obtaining information about the world through the senses.

**Perceptual Constancy**

A general term referring to the tendency of objects to be perceived in the same way despite wide variations in the manner of viewing them.

**Performance Concept**

An organized procedure or framework within which it is possible to state the desired attributes of a material component or system in order to fulfill the requirements of the intended user without regard to the specific means to be employed in achieving the results.

**Permanent Threshold Shift (PTS)**

A permanent increase in a hearing threshold level, e.g., the loss of hearing that results from exposure to noise.

**Permissive**

An attitude which grants freedom of choice and expression to another person out of respect for his personality.

**Personal Space**

The normal spacing between individuals in their environments.

**Phenomenologist**

Pursues the philosophical study of the progressive development of the mind.

**Phonetically Balanced (PB) Words**

A list of monosyllabic words that contains a distribution of speech sounds that approximates the distribution of the same sounds as they occur in conversational American English.



## Photometric Room Layout (Body Measures - Hunt & Giles)

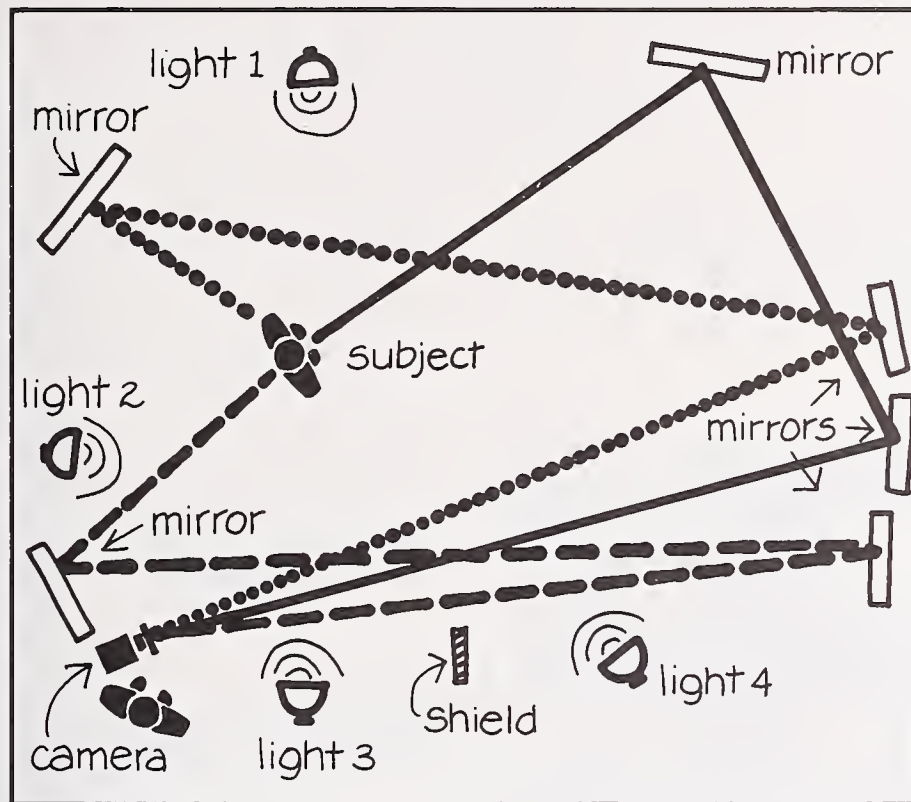

Focal paths:



### Phototropic

Tendency to involuntarily look at brightest spot.

### Pilot Study

Preliminary limited research performed as a forerunner to an experiment, e.g., to test the adequacy of a research approach.

### Pink Noise

Noise that when averaged over a period of time will show equal energy in each frequency interval (e.g., octave bands, 1/3-octave bands, etc.).

### Population

In statistics, any collection or aggregation of individual units, e.g., buildings.

### Preferred Noise Criterion (PNC)

Modification of the currently used Noise Criterion (NC) curves.

### Proxemics

A formulation which describes relationships among people and animals in terms of distance, where physical distance may be described on the basis of cultural, behavioral, physiological, and social factors.

### Psychoacoustics

A discipline that links physics and psychology which deals with the physical phenomena of sound as related to audition, as well as with the physiology and psychology of sound receptor processes.

### Psychoanalysis

A systematic approach to the study of human functioning, normal and abnormal, originated by Freud. The psychoanalytic method is designed to bring about accessibility to the unconscious process in the patient, and enable him to master those forces previously unknown to him which have seriously impaired his ability to function satisfactorily.

### Psychology

A branch of science dealing with the behavior of organisms.

### Psychophysics

The branch of psychology which investigates the relationships between physical stimulus magnitudes, or the differences between stimuli and the corresponding sensory experiences.

### Public Opinion Poll

A sampling of the general state of feeling, opinion, or attitude of some predefined segment of the population on an issue or group of issues.

### Pulse Rate

The rate of the rhythmic rise and fall of pressure at a given point in the arteries, resulting from heart action.

### Pupillometer

An instrument which measures changes in eye pupil size; used in studying emotional responses and other phenomena related to eye pupil changes.

### Qualitative

Concerned with characteristics, properties, or attributes not specified in numerical terms.

### Quantitative

Pertaining to the description or measurement of anything in numerical terms.

### Questionnaire

A set of questions, often elaborate, which is designed so as to investigate a given subject.

### Questionnaire Items

Questions which make up a questionnaire survey.

## Radiation

1. Diffusion in all directions from a source or center. 2. The spreading of neural excitation to adjacent nerve elements. 3. Emitted waves or particles, or the process of such emission.

## Random

Occurring by chance, without voluntary control.

## Random Noise

Noise that when averaged over a period of time will show equal energy at all frequencies in the audio range. (The magnitude of any specific frequency at any given point in time is random.)

## Random Sample

A sample selected by using a random selection procedure.

## Ratio Scale

A type of scale consisting of magnitudes with an absolute zero point, for which both intervals (differences) and ratios can be calculated. All statements of ratio must be based on this scale.

## Reflection

The reversal or turning back of particles or waves which strike a surface.

## The Radiant Energy Spectrum

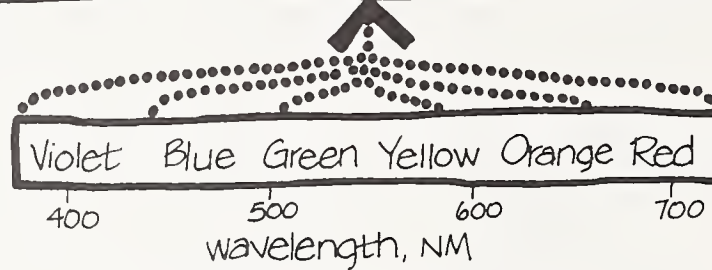
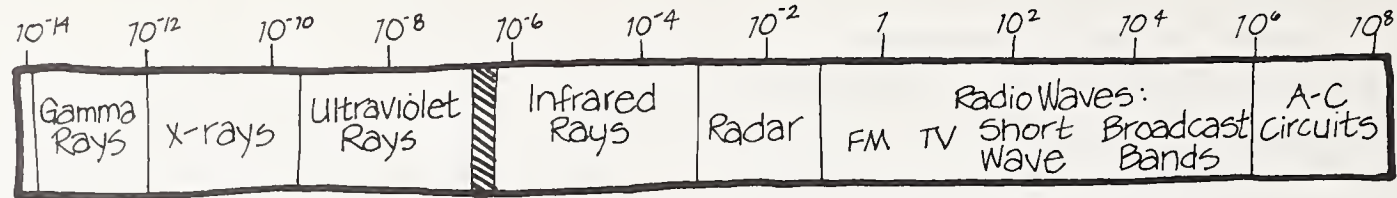

The Visible Spectrum

## Reflection

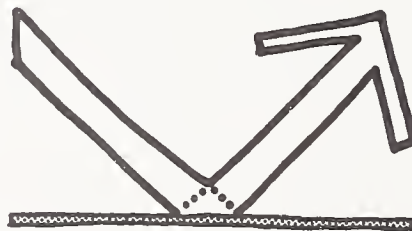

Smooth surface

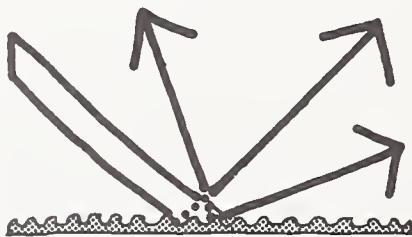

Rough surface

Reflection of light from a glossy material and from a matte (nonglossy) material.

## Refraction

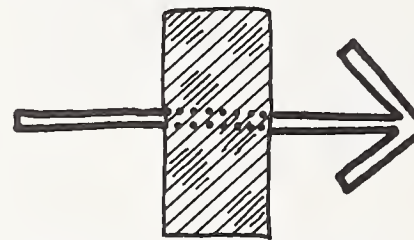

Particles & medium have the same refractive index

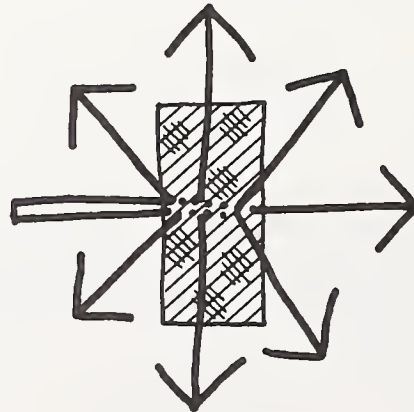

Particles & medium have different refractive indexes

## Refraction

A change or bending in the direction of flow of a wave, especially of a light wave, caused by passage of the wave from one medium to another.

## Relativity

The attitude or belief that the truth of anything is always dependent on the context, that standards of conduct are not absolute but relative to time, place, culture, and historical circumstances.

## Relatoscope

An instrument used in assessing an individual's perception of an environment. The relatoscope is a long pencil-shaped tube with a lens; it extends from a mobile television camera down into a naturalistic model giving a view from eye level.



**Reliability**

The degree to which results are consistent upon repetition of an experiment, or test.

**Requirements**

Needs of the user (of a building) such as those of health, safety, and comfort.

**Response (R)**

1. Any overt or covert behavior. 2. Any process in the body of an organism which results from stimulation.

**Rhodopsin**

A substance found in the rods of the dark adapted eye, which bleaches on exposure to the light.

**Rods**

Rod-shaped cells in the retina which are thought to be the specific structures for the reception of light for vision at the lower intensities. Rod vision is achromatic—in shades of gray.

**Sample**

A part of a larger set, usually selected deliberately, to investigate the properties of the parent population.

**Sample Size**

The number of sampling units included in a given sample.

**Saturation**

The degree to which any color possessing a hue differs from a gray of the same brightness.

**Scale**

Any series of items which is progressively arranged according to value or magnitude, into which an item can be placed according to its quantification.

**Scale Model**

Reduced-size physical representation of some aspect of the real world.

**Scentometer**

An instrument used in measuring odor intensities. A combination of critically sized holes admits ambient air to a mixing chamber which then passes through two nosepieces on the way to the subject's lungs.

### Sample Shares Characteristics with Population

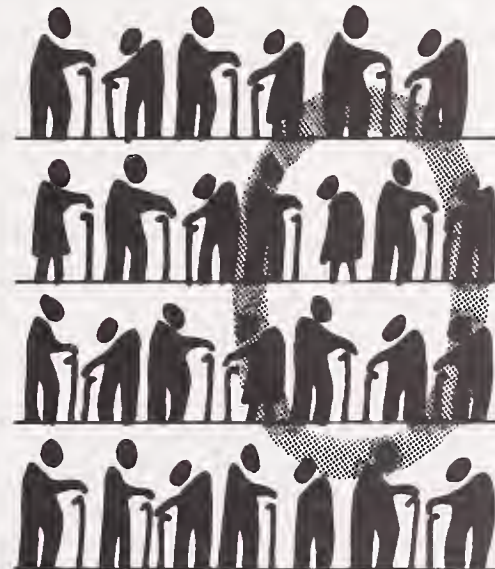

## Decibel Scale - Representative Levels (Stevens)

VISION	decibels	AUDITION
Luminance of sun	160	
	150	
	140	Jet plane with afterburner
	130	
Discomfort	120	Pain
Sunlight on snow	110	Discomfort
	100	
Luminance of moon	90	Subway
	80	Heavy traffic
Good reading light 1 candela/sq. meter	70	
	60	Normal conversation
	50	
	40	
Photopic threshold	30	Whisper
	20	
	10	
	0	

**Scientific Approach**

Principles and procedures for the systematic pursuit of knowledge involving the recognition and formulation of a problem, the collection of data through observation and experiment, and testing of hypotheses.

**Semantic Differential**

A method of measuring the subjective reaction to a concept or actual environment in which the person rates the concept on one or more bipolar scales.

**Semi-Fixed Feature**

Feature of building to which limited modification is acceptable and possible.

**Sensation**

Immediate elementary experiences requiring no verbal, symbolic, or conceptual elaboration, and related primarily to sense organ activity such as occurring in an eye or ear and in the associated nervous system leading to a particular sensory area in the brain.

**Settled Distance**

The distance maintained between two individuals following adjustments after arrival of one of them.

**Signal-to-Noise (S/N) Ratio**

The ratio of the signal intensity to noise intensity, usually expressed as the decibel difference between the signal level and the noise level.

**Significant Difference**

A difference in measured values which cannot reasonably be attributed to chance factors.

**Silent Language**

Nonverbal communication whereby the individual reacts to subtle influences such as gestures and other body and facial movements.

**Simple Reaction Time**

The time from the onset of a single stimulus until the organism responds.

**Simulation**

The imitation of certain environmental and other conditions for purposes of training or experimentation.

**Sinusoidal**

Characterized by simple harmonic, vibratory motions, such as those of the sine wave.

**Snellen Eye Chart**

A test of visual acuity consisting of a chart of printed letters ranging from very large to very small which the subject is asked to read at a predetermined distance.

**Social Distance**

The relative accessibility of one person or group to association with another person or group; the degree of intimacy with which a person is willing to associate with another person or group.

**Social Psychology**

The branch of psychology concerned with the study of individuals in groups. It deals with the psychological processes and interpersonal interactions in groups and between groups.

**Sociofugal**

An arrangement of people maximizing interpersonal distance.

**Sociogram**

(Moreno) a diagram in which group interactions are analyzed on the basis of mutual attractions or antipathies between group members.

**Sociology**

The science of human societies, groups, organizations, and institutions.

**Sociometry**

(Moreno) a technique for the measurement of attraction and repulsion among people which uses the method of the sociogram, a diagram in which group interactions are analyzed on the basis of mutual attractions or antipathies between group members.

**Soclopetal**

An arrangement of people in small groups with little space between persons, as around two small tables in the middle of a large room.

**Sone**

The sone is a unit of loudness. By definition, a simple tone of frequency 1000 Hz, 40 dB above a listener's threshold, produces a loudness of 1 sone. The loudness of any sound that is judged by the listener to be  $n$  times that of the 1-sone tone is  $n$  sones.

**Sound**

1. An oscillation in pressure, stress, particle displacement, particle velocity, etc., in a medium. 2. An auditory sensation evoked by the oscillation described above.

**Sound Insulation**

The use of structures and materials designed to reduce the transmission of sound from one room or area to another or from the exterior to the interior of a building.

**Sound Level (noise level)**

Sound level is the frequency-weighted sound pressure level measured by the use of a sound level meter with A, B, or C weightings.

**Sound Level Meter**

An instrument, comprising a microphone, an amplifier, an output meter, and frequency-weighting networks, that is used for the measurement of noise and sound levels in a specified manner.

**Sound Transmisslon Class (STC)**

The preferred single figure rating system designed to give an estimate of the sound insulation properties of a partition or a rank ordering of a series of partitions. It is intended for use primarily when speech and office noise constitute the principal noise problem.

**Spectrophotometer**

An instrument used to measure the fraction of light transmitted through or reflected from an object, wavelength by wavelength, throughout the visible spectrum.

**Speech Communication (SC)****Crilterlon Curve**

One of a family of curves generated to indicate different amounts of speech interference in auditory environments.

**Speech Interference Levels (SIL)**

Calculated quantities providing a guide to the interfering effect of a noise on speech. The speech interference level is the arithmetic average of the sound pressure levels of noise in the most important part of the speech frequency range—commonly the three octave-frequency bands centered at 500, 1000, and 2000 Hz.

**Speech Spectrogram**

A graphic recording of speech used as a method of analyzing speech into its component frequencies.

**Standard**

In experimental psychology, a constant stimulus against which varying stimuli are compared.



### Standard Deviation

A statistical measure of the variability of scores in a frequency distribution; provides a basis for expressing scores in terms of norms.

### Standing Pattern

A discrete behavioral entity taking place at a given place at a particular time—e.g., worship service, piano lesson.

### Statistical Probability

The likelihood of an occurrence, expressed by the ratio of the number of actual occurrences to that of possible occurrences; the relative frequency with which an event occurs or is likely to occur.

### Statistical Significance

The degree of probability that, in an infinite series of measurements of the kind in question, the value or score obtained will not by chance alone occur with significant frequency, hence can be attributed to something other than chance.

### Stereophotography

A photographic method used for recording very detailed information about a bodily movement. The stereo camera consists of two interconnected cine cameras with synchronized exposures.

### Stimulus (S)

Any action or situation that elicits response from an organism.

### Stratified Sample

A sample selected from a population which has been divided into parts, a portion of the sample coming from each stratum.

### Stress

A condition of physical or mental strain which produces changes in the autonomic nervous system.

### Stroboscope

An instrument for determining speeds of rotation or frequencies of vibration of a revolving disk with holes around the edge through which an object is viewed.

### Subject

The person or animal to whom stimuli are applied for the purpose of evoking responses; or, more generally, the person whose reactions are observed.

### Subjective

1. Referring to experience available only to the person having the experience. 2. Referring to judgments made without the use of devices or instruments.

### Subsystem

A major functional part of a system, usually consisting of several components, such as equipment, activities performed by people, or a combination of the two.

### Subtractive Mixture

Color which is formed by selectively absorbing, or subtracting out certain wavelengths from light.

### Suprathreshold Task

A task which requires a judgment of how well an object can be seen.

### Surface-Color Solid

A three-dimensional diagram, each point of which represents a unique color. In the Munsell surface-color solid, the central axis represents lightness, the distance from this axis is saturation, and the angle about the central axis is hue.

### Survey

A method of collecting data by sampling a cross section of people, as distinguished from experimental methods.

### System

An organized arrangement in which each component part responds in accordance with an overall design. It includes all equipment and personnel integrated in a manner to perform a function.

### Tachistoscope

An apparatus used in experimental studies of perception, learning, etc., for exposure of visual stimuli (photos, digits) for brief intervals.

### Task

A group of related job elements performed to accomplish work, e.g., discrimination, decisions, motor actions related to one another.

### Task Analysis

Task analysis is used to determine the psychological and physical factors essential to the adequate performance of a task. Its goal is to define the critical activities occurring in an operational or training situation in

such a way as to provide a sound basis for performance evaluation.

### Telephone Survey

Usually a questionnaire survey conducted over the telephone.

### Temporary Threshold Shift (TTS)

A temporary increase in a hearing threshold level resulting from exposure to noise.

### Territoriality

The perception of a person or group that they possess a given place, and all others are intruders there.

### Territory

Domain of an animal which is defended upon intrusion by another animal of the same or a different species.

### Threshold

(Psychophysics) the minimum stimulus energy or energy change necessary for an experimental subject to indicate an awareness of the stimulus or stimulus change.

## Thresholds-Vibration

(Chen, Robertson)

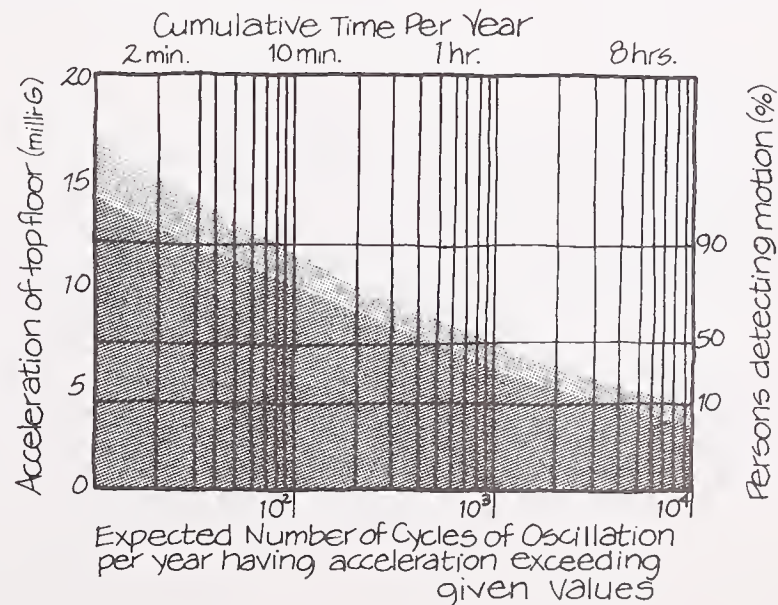

**Time and Motion**

A study involving the observation and analysis of movements in a task with an emphasis on the amount of time required to perform the task.

**Time Budget Study**

A record is made of what a person has done during a specified period of time.

**Trace Photography**

A photographic method of recording behavior in which the most interesting points on the object or test subject are fitted with small lights. Light tracks of the subject are recorded by making a time exposure of his movements in a dark room.

**Tracking Tasks**

Tasks involving intermittent or continuous adjustment of an instrument or machine to maintain a desired or normal value, or to follow a moving reference marker.

**Traffic Noise Index (TNI)**

A measure of the noise environment created by highways; it is computed from measured values of the sound levels exceeded 10% and 90% of the time.

**Transient Adaptation**

A brief variation in an observer's condition of visual adaptation caused by momentary exposure to a stimulus differing from the more stable background (as by being brighter or dimmer).

**Transmission Loss (TL)**

A measure of sound insulation provided by a structural configuration. Expressed in decibels, it is 10 times the logarithm to the base 10 of the reciprocal of the sound transmission coefficient of the configuration. (The sound transmission coefficient is the fraction of incident sound energy transmitted through a structural configuration).

**Transposition**

1. The reaction to the relationships among stimuli rather than to the absolutes of the stimuli. 2. The interchange of spatial, logical, or psychological relationships between two units of a system.

**Trend Analysis**

The statistical analysis of a series of measurements of a variable, taken at several points in time, in order to discover whether there is a basic direction of change.

**Triangle Test**

A method for selecting subjects for participation in odor tests. The person is presented with three odors, two of which are identical, and is asked to select the odd one. A series of such trials constitutes the triangle test.

**Unobtrusive Measures**

Methods of studying behavior which do not interfere with the normal environment in which the behavior occurs. The researcher observes without intruding into the scene.

**User**

An occupant of a building, i.e., anyone who uses or performs activities in a building.

**Validity**

The degree to which a research study or test can predict performance in a realistic situation—that is, where the problem investigated actually exists.

**Value**

Relative lightness or darkness of a color.

**Vapor Dilution Method**

A method of determining odor threshold levels by mixing various amounts of uncontaminated air with odorous air.

**Variable**

1. A factor the quantity of which can be increased or decreased either in discrete or continuous steps or along some continuum without any other concomitant change in that factor. 2. Anything that can change or take on different characteristics appropriate to specified conditions.

**White Noise**

An acoustical stimulus composed of all audible frequencies at the same intensity with random phase relations between them; it sounds like "shhhhhhhhhhh."

**Word Association Test**

A projective technique consisting of a list of words which is presented to the subject one at a time. The subject is asked to respond with the first word that comes into his mind.



# Bibliography

To further guide the reader, one or more of the following descriptive codes appears after each entry.

- [1] Popular treatment serving as a good introduction to a subject
- [2] Detailed technical work on a particular subject
- [3] Edited compendium of research studies covering a restricted range of subjects
- [4] Edited compendium of research studies covering a broad range of subjects
- [5] Handbook containing densely packed information
- [6] Theoretical work
- [7] Research study, typically a journal article
- [8] Literature search

## GENERAL REFERENCES

- Archea, J., & Eastman, C. (Eds.),** *EDRA 2: Proceedings of the 2nd Annual Environmental Design Research Association Conference*. Pittsburgh, Pa.: Carnegie-Mellon University, October 1970. [4]
- Bell, G., Randall, E., & Roeder, J.,** *Urban Environments and Human Behavior: An Annotated Bibliography*, (Community Development Series). Stroudsburg, Pa.: Dowden, Hutchinson & Ross, 1973. [8]
- Bliss, W. (Ed.),** *Proceedings of the Symposium on Environmental Effects on Behavior*, Montana State University, July 21-22, 1975. [4]
- Borgata, E. F. (Ed.),** *Social Psychology: Readings and Perspective*. Chicago: Rand McNally, 1969. [4]
- Broadbent, G.,** *Design in Architecture—Architecture and the Human Sciences*. New York: John Wiley & Sons, 1973. [2]
- Canter, D. V. (Ed.),** *Architectural Psychology: Proceedings of the Conference at Dalandhvi*, University of Strathclyde, U.K., February 23-March 1, 1969. [4]

- Canter, D. V. (Ed.),** *Architectural Psychology*. London: RIBA, 1970. [4]
- Canter, D. V., & Lee, T. R. (Eds.),** *Psychology and the Built Environment*. London: Architectural Press, 1974. [4]
- Canter, D. V. et al.,** *Environmental Interaction—Psychological Approaches to Our Physical Surroundings*. London: Surrey University Press, 1975. [2]
- Coates, G. J., & Moffett, K. M. (Eds.),** *Response to Environment, Student Publications of the School of Design*, (Vol. 18). Raleigh, N.C.: North Carolina State University, 1969. [4]
- Craik, K. H. et al.,** *New Directions in Psychology 4*. New York: Holt, Rinehart & Winston, 1970. [8]
- Ellingstad, U. S., & Helmstra, N. W.,** *Methods in the Study of Human Behavior*. Monterey, Calif.: Brooks/Cole, 1974. [2]
- Galtung, J.,** *Theory and Methods of Social Research*. New York: Columbia University Press, 1969. [2]
- Gutman, R. (Ed.),** *People and Buildings*. New York: Basic Books, 1972. [4]
- Helmstra, N. W., & Ellingstad, U. S.,** *Human Behavior: A Systems Approach*. Monterey, Calif.: Brooks/Cole, 1972. [2]
- Helmstra, N. W., & McFarling, L. H.,** *Environmental Psychology*. Monterey, Calif.: Brooks/Cole, 1974. [2]
- Honkman, B. (Ed.),** *Proceedings of the Architectural Psychology Conference at Kingston Polytechnic*. [4]
- Honkman, B. (Ed.),** *Responding to Social Change*, (Community Development Series). Stroudsburg, Pa.: Dowden, Hutchinson & Ross, 1975. [4]
- Ittleson, W. H. (Ed.),** *Environment and Cognition*. New York: Seminar Press, 1973. [3]
- Kuller, R. (Ed.),** *Architectural Psychology—Proceedings of the Lund Conference*. Stroudsburg, Pa.: Dowden, Hutchinson & Ross, 1973. [4]
- Lang, J. (Ed.),** *Designing for Human Behavior: Architecture and the Behavioral Sciences*, (Community Development Series). Stroudsburg, Pa.: Dowden, Hutchinson & Ross, 1974. [4]
- Lee, T.,** "Psychology and living space." *Transactions of the Barlett Society*, 1963-64, 2, 87-108. [7]

**Michelson, W.**, *Man and His Urban Environment: A Sociological Approach*. Reading, Mass.: Addison-Wesley, 1970. [2]

**Michelson, W.**, *Behavioral Research Methods in Environmental Design*, (Community Development Series). Stroudsburg, Pa.: Dowden, Hutchinson & Ross, 1975. [2]

**Mitchell, W. J. (Ed.)**, *Environmental Design: Research and Practice, Proceedings of the EDRA 3/AR 8 Conference*, Los Angeles: University of California at Los Angeles, 1972. [4]

**Perin, C.**, *With Man in Mind: An Inter-Disciplinary Prospectus for Environmental Design*. Cambridge, Mass.: MIT Press, 1970. [2,6]

**Preiser, W. F. E. (Ed.)**, *Environmental Design Research: Proceedings of the 4th Annual Environmental Design Research Association Conference* (2 vols.), (Community Development Series). Stroudsburg, Pa.: Dowden, Hutchinson & Ross, 1973. [4]

**Proshansky, H. M., Ittleson, W. H., & Rivlin, L. G. (Eds.)**, *Environmental Psychology: Man and His Physical Setting*. New York: Holt, Rinehart & Winston, 1970. [4]

**Raskin, E.**, *Architecture and People*. Englewood Cliffs, N.J.: Prentice-Hall, 1974. [2]

**Rubin, A. I., & Elder, J.**, *User Requirements in the Home—Data Collection Methodology—A State of the Art Report* (NBS Report 10 852). Washington, D.C.: National Bureau of Standards, 1971. [2,8]

**Sanoff, N., & Cohen, S. (Eds.)**, *EDRA I: Proceedings of the 1st Annual Environmental Design Research Association Conference*, Chapel Hill, N.C., June 1969. [2]

**Wohlwill, J. F.**, "The averaging discipline of environmental psychology." *American Psychologist*, 1970, 25, 303-312. [4]

**Zeisel, J.**, *Social Science Frontiers: 6, Sociology and Architectural Design*. New York: Russell Sage Foundation, 1975. [1]

## CHAPTER 1. INTRODUCTION

**Giedion, S.**, *Space, Time and Architecture* (5th ed.). Cambridge, Mass: Harvard University Press, 1974. [2]

**Gropius, W.**, *The New Architecture and the Bauhaus*. London: Faber, 1935. [1]

**Gropius, W.**, *Scope of Total Architecture*. New York: MacMillan, 1970. [1]

**Neutra, R.**, *Survival Through Design*. New York: Oxford University Press, 1969. [2]

**Wright, J. R.**, "Performance Criteria in Buildings." *Scientific American*, 1971, 224(3). [7]

## CHAPTER 2. BACKGROUND

**Caudill, W. W.**, *Architecture by Team*. New York: Van Nostrand Reinhold, 1971. [1]

**Doxiadis, C. A.**, *Architecture in Transition*. New York: Oxford University Press, 1968. [2]

**Maslow, A. H.**, *Motivation and Personality*. New York: Harper & Row, 1954. [2]

**Sommer, R.**, *Tight Spaces: Hard Architecture and How to Humanize It*. Englewood Cliffs, N.J.: Prentice-Hall, 1974. [1]

## CHAPTER 3. DESIGN/BEHAVIORAL RESEARCH BRIDGES

**American Institute of Architects.** *Emerging Techniques 2: Architectural Programming*. Washington, D.C.: Author, 1969. [7]

**Brill, M.**, "Evaluating Buildings on a Performance Basis." In J. Lang (Ed.), *Designing for Human Behavior: Architecture and the Behavioral Sciences*, (Community Development Series). Stroudsburg, Pa.: Dowden, Hutchinson & Ross, 1974. [7]

**Cooper, C. C.**, *Easter Hill Village*. New York: MacMillan, 1975. [2]

**Cooper, C. & Hackett, P.**, *Analysis of the Design Process at Two Moderate-Income Housing Developments* (Working Paper No. 80). Berkeley, Calif.: University of Calif., Department of Landscape Architecture, June 1968. [7]

**Cronberg, T.**, *Performance Requirements for Buildings—A Study Based on User Activities*. (Swedish Council for Building Research D3: 1975). [2]

**Eberhard, J. P. (Ed.)**, *The Performance Concept: A Study of Its Application to Housing*, Vols. 1, 2, & 3. Washington, D.C.: National Bureau of Standards, June 1969. [2]

**Gustafson, C. E.**, *Pocket Glossary for Personnel Subsystem Development*. Wright-Patterson AFB, Ohio: Wright Air Development Division, 1960. [1]

**Hester, R. T., Jr.**, *Neighborhood Space*, (Community Development Series, Vol. 17). Stroudsburg, Pa.: Dowden, Hutchinson & Ross, 1975. [1]

**Horowitz, H.**, "The architect's program and the behavioural sciences." *Architectural Science Review*, 1966, 9(3), 71-79. [7]

**Ittleson, W. H., Proshansky, H. M., & Rivlin, L. G.**, "Bedroom size and social interaction on the psychiatric ward." *Environment and Behavior*, 1970, 2(3), 255-270. [7]



- Kraegel, J. M., Mosseau, V., Goldsmith, C., & Arora, R.,** *Patient Care Systems*. Philadelphia: Lippincott, 1974. [2]
- Markus, T. A.,** "The role of building performance measurement and appraisal in design method." *The Architects' Journal Information Library*, December 20, 1967. [7]
- Michelson, W., & Reed, P.,** "The time budget." In W. Michelson (Ed.), *Behavioral Research Methods in Environmental Design*. Stroudsburg, Pa.: Dowden, Hutchinson & Ross, 1975. [4]
- Miller, R.,** *A Method for Man-Machine Task Analysis* (RDO No. 694-44). Wright-Patterson Air Force Base, Ohio: Aero-Med Laboratory, Wright Air Development Center, 1953. [7]
- Performance Concept in Buildings—Joint RILEM-ASTM-CIB Symposium Proceedings* (National Bureau of Standards Special Publication 361). Washington, D.C.: National Bureau of Standards, 1972. [4]
- Programming of Buildings: A Seminar Course of the AIA Professional Development Program*. American Institute of Architects, December 5-6, 1969 (Instructors: Gerald Davis and Sandra Ellis). [2]
- Rubin, A. I.,** *Energy Conservation in Buildings—A Human Factors/Systems Viewpoint* (National Bureau of Standards Building Science Series 88). Washington, D.C.: U.S. Government Printing Office, 1976. [7]
- Sanoff, H.,** *Techniques of Evaluation for Designers*. Raleigh, N.C.: North Carolina State University, School of Design, 1970. [2]
- Suchman, E. A.,** *Evaluative Research, Principles and Practice in Public Service and Social Action Progress*. New York: Russell Sage Foundation, 1967. [2]
- Van Ettinger, J.,** *Decision Making and Functional Principles of Housing*. Rotterdam: Bouwcentrum, January 1970. [2]
- White, E. T.,** *Introduction to Architectural Programming*. Tucson, Arizona: Architectural Media, 1972. [1]
- Wright, J. R.,** "Performance criteria in buildings." *Scientific American*, 1971, 224(3). [7]

## CHAPTER 4. SCIENTIFIC APPROACH

- Alexander, C.,** *Notes on the Synthesis of Form*. Cambridge, Mass.: Harvard University Press, 1964. [2,6]
- Bechtel, R. B., Achelpohl, C., & Akers, R.,** *Television and Social Behavior* (Technical report to the Surgeon General's Scientific Advisory Committee on Television and Social Behavior). Rockville, Md.: U.S. Department of Health, Education, and Welfare. [7]

- Bernard, C.,** *An Introduction to the Study of Experimental Medicine*. New York: Dover, 1957. [2]
- Blalock, H. M., & Blalock, A. B. (Eds.),** *Methodology in Social Research*. New York: McGraw-Hill, 1968. [4]
- Boring, E. G.,** *History of Experimental Psychology*. New York: Appleton-Century-Crofts, 1950. [2]
- Bridgman, P. W.,** *The Logic of Modern Physics*. New York: Macmillan, 1960. [2]
- Craik, K. H.,** "Human responsiveness to landscape: An environmental psychological perspective." In G. J. Coates & K.M. Moffett (Eds.), *Response to Environment, Student Publications of the School of Design* (Vol. 18). Raleigh: North Carolina State University, 1969. [7,4]
- Craik, K. H.,** "The assessment of places." In P. McReynolds (Ed.), *Advances in Psychological Assessment* (Vol. 2). Palo Alto, Calif.: Science and Behavior Books, 1971. [7,4]
- Fechner, G. T.,** In Boring, E. G., *A History of Experimental Psychology* (2nd ed.). New York: Appleton-Century-Crofts, 1950. [2]
- Filstead, W. J. (Ed.),** *Qualitative Methodology: Firsthand Involvement with the Social World*. Chicago: Markham, 1970. [2]
- Koch, S. (Ed.),** *Psychology: A Study of a Science: Study I, Conceptual and Systematic* (Vol. 1, Sensory, Perceptual, and Physiological Formulations). New York: McGraw-Hill, 1959. [4]
- Koch, S. (Ed.),** *Psychology: A Study of a Science: Study I, Conceptual and Systematic* (Vol. 3, Formulation of the Person and the Social Context). New York: McGraw-Hill, 1959. [4]
- Koch, S. (Ed.),** *Psychology: A Study of a Science: Study II, Empirical Substructure and Relations with Other Sciences* (Vol. 6, Investigations of Man as Socius: Their Place in Psychology and the Social Sciences). New York: McGraw-Hill, 1963. [4]
- Lynch, K.,** *The Image of the City*. Cambridge, Mass.: Harvard University Press, 1960. [2,6]
- Rosenthal, R.,** *Experimenter Effects in Behavior Research*. New York: Appleton-Century-Crofts, 1966. [2]
- Skinner, B. F.,** *Science and Human Behavior*. New York: Macmillan, 1953. [2]
- Stevens, S. S.,** *Psychophysics*. New York: John Wiley & Sons, 1975. [2]
- Wilson, E. B.,** *An Introduction to Scientific Research*. New York: McGraw-Hill, 1952. [2]
- Woodworth, R. S.,** *Experimental Psychology*. New York: Holt, Rinehart and Winston, 1938. [2]

## CHAPTER 5. MAN/ENVIRONMENT RESEARCH

- Aas, D.**, "Observing environmental behavior: The behavior setting." In W. Michelson (Ed.), *Behavioral Research Methods in Environmental Design*. Stroudsburg, Pa.: Dowden, Hutchinson & Ross, 1975. [7,4]
- Abelson, R. P.**, "Simulation of social behavior." In G. Lindzey & E. Aronson (Eds.), *The Handbook of Social Psychology* (2nd ed., vol. 2). Reading, Mass.: Addison-Wesley, 1968. [7,4]
- Barker, R. G.**, *Ecological Psychology: Concepts and Methods for Studying the Environment of Human Behavior*. Stanford, Calif.: Stanford University Press, 1968. [2,6]
- Bechtel, R. B.**, "The semantic differential and other paper-and-pencil tests." In W. Michelson (Ed.), *Behavioral Research Methods in Environmental Design*. Stroudsburg, Pa.: Dowden, Hutchinson & Ross, 1975. [7,4]
- Bloomfield, B. C., & Hay, D. C.**, *The Auditory Environment in the Home*. Milwaukee, Wis.: Koss Electronics, 1971. [7]
- Blum, M.**, *Industrial Psychology and Its Social Foundations*. New York: Harper Bros., 1949. [2]
- Blum, M., & Candee, B.**, "Family living as a basis for dwelling design." In *Family Behavior, Attitudes and Possessions* (Vol. 4). New York: John B. Pierce Foundation, 1944. [2]
- Chapin, F. S.**, "The study of urban activity systems." In F. S. Chapin, *Urban Land Use Planning* (2nd ed.). Urbana, Ill.: University of Ill. Press, 1965. [2]
- Cohn, S.**, "Simulating the architectural control process." In G. J. Coates & K. M. Moffett (Eds.), *Response to Environment, Student Publications of the School of Design* (Vol. 18). Raleigh, N.C.: North Carolina State University, 1969. [7,4]
- Fitch, J. M.**, *The Architectural Manipulation of Space, Time, and Gravity*. New York: Columbia University, 1969. [2]
- Lau, J.**, "Use of scale models as a stimulus mode." In J. Archa & C. Eastman (Eds.), *EDRA 2: Proceedings of the 2nd Annual Environmental Design Research Association Conference*. Pittsburgh, Pa.: Carnegie-Mellon University, 1970. [7,4]
- Markus, T. A.**, "The role of building performance measurements and appraisal in design method." *The Architects' Journal Information Library*, December 20, 1967. [7]
- Newman, O.**, *Defensible Space: Crime Prevention Through Urban Design*. New York: Macmillan, 1972. [2]

**Osgood, C. E., Sucl, G. J., & Tannenbaum, P. H.**, *The Measurement of Meaning*. Urbana, Ill.: University of Ill. Press, 1967. [2,6]

**Seaton, R., & Collins, J. B.**, "Validity and reliability of ratings of simulated buildings." In W. J. Mitchell (Ed.), *Environmental Design: Research and Practice, Proceedings of the EDRA 3/AR 8 Conference*. Los Angeles: University of California at Los Angeles, 1972. [7,4]

**Shils, K. A.**, "Social inquiry and the autonomy of the individual." In D. Lerner (Ed.), *The Human Meaning of the Social Sciences*. Cleveland, Ohio: Meridian, 1959. [4]

**Stevens, S. S.**, *Psychophysics*. New York: John Wiley & Sons, 1975. [2]

**Webb, E. J. et al.**, *Unobtrusive Measures: Nonreactive Research in the Social Sciences*. Chicago: Rand McNally, 1966. [1]

**Willis, C. W.**, "An empirical study of bathtub and shower accidents." In W. D. Bliss (Ed.), *Symposium on Environmental Effects on Behavior*. Bozeman: Montana State University, 1975. [7,4]

**Winkel, G., Malek, R., & Thiel, P.**, "A study of human response to selected roadside environments." In H. Sanoff & S. Cohn (Eds.), *EDRA I: Proceedings of the 1st Annual Environmental Design Research Association Conference*. Raleigh: North Carolina State University, 1970. [7,4]

## CHAPTER 6. SCALES OF OBSERVATION

**Downs, R. M., & Stea, D. (Eds.)**, *Image and Environment—Cognitive Mapping and Spatial Behavior*. Chicago, Ill.: Aldine, 1973. [2]

**Esser, A. H., Chamberlain, A. S., Chapple, E. D., & Kilne N. S.**, "Territoriality of patients on a research ward." In H. M. Proshansky, W. H. Ittleson L. G. Rivlin (Eds.), *Environmental Psychology: Man and His Physical Setting*. New York: Holt, Rinehart & Winston, 1970. [7,4]

**Godschalk, D.**, "Negotiate: An experimental planning game." In H. Sanoff & S. Cohn (Eds.), *EDRA I: Proceedings of the 1st Annual Environmental Design Research Association Conference*. Raleigh: North Carolina State University, 1970. [7,4]

**Grandjean, E.**, *Ergonomics of the Home*. New York: Halsted Press, 1974. [5,2]

**Ittleson, W. H., Rivlin, L. G., & Proshansky, H. M.**, "The use of behavioral maps in environmental psychology." In H. M. Proshansky, W. H. Ittleson & L. G. Rivlin (Eds.), *Environmental Psychology: Man and His Physical Setting*. New York: Holt, Rinehart & Winston, 1970. [7,4]

**Keller, S.**, *The Urban Neighborhood: A Sociological Perspective*. New York: Random House, 1968. [2]



- Ladd, F.**, "Black youths view their environment: Neighborhood maps." *Environment and Behavior*, June 1970, 2(1), 74-99. [7]
- Lowrey, R.**, "Distance concepts of urban residents." *Environment and Behavior*, June 1970, 2(1), 52-73. [7]
- Lynch, K.** *The Image of the City*. Cambridge, Mass.: Harvard University Press, 1960. [2,6]
- Perlin, D.**, "Concepts and methods for studying environments in use." In W. J. Mitchell (Ed.), *Environmental Design: Research and Practice*, Proceedings of the EDRA 3/AR 8 Conference. Los Angeles: University of California at Los Angeles, 1972. [7,4]
- Peterson, G. L.**, "A model of preference: Quantitative analysis of the perception of the visual appearance of residential neighborhoods." *Journal of Regional Science*, 1967, 7(1), 19-30. [7]
- Southworth, M.**, "The sonic environment of cities." *Environment and Behavior*, June 1969, 1(1), 49-70. [7]
- Wilson, R. L.**, "Livability of the city: Attitudes and urban development." In F. S. Chapin & S. F. Wiss (Eds.), *Urban Growth Dynamics in a Regional Cluster of Cities*. New York: John Wiley & Sons, 1962. [7,4]
- Wirth, L.**, *On Cities and Social Life*. Chicago: University of Chicago Press, 1964. [2]
- Worrall, R., Peterson, G., & Redding, M. J.**, "Toward a theory of accessibility acceptance." In H. Sanoff & S. Cohn (Eds.), *EDRA I: Proceedings of the 1st Annual Environmental Design Research Association Conference*. Raleigh: North Carolina State University, 1970. [7,4]
- Dabbs, J. M., Jr., Fuller, J., & Carr, T.**, "Personal space when "cornered": College students and prison inmates." *Proceedings of the 81st Annual Convention of the American Psychological Association*, 1973, 213-214. [4]
- Dreyfuss, H.**, *The Measure of Man: Human Factors in Design* (2nd ed.). New York: Whitney Library of Design, Billboard Publications, 1967. [5,1]
- Evans, G. W., & Howard, R. B.**, "A methodological investigation of personal space." In W. J. Mitchell (Ed.), *Environmental Design: Research and Practice*, Proceedings of the EDRA 3/AR 8 Conference. Los Angeles: University of California at Los Angeles, 1972. [7,4]
- Hall, E. T.**, *The Silent Language*. Garden City, N.Y.: Doubleday, 1959. [1,6]
- Hall, E. T.**, *The Hidden Dimension*. New York: Doubleday, 1966. [1,6]
- Hansen, R., & Cornog, D. Y.**, *Annotated Bibliography of Applied Physical Anthropology in Human Engineering* (WADC Tech. Rep. 56-30). Wright-Patterson Air Force Base, Ohio: Aero Medical Laboratory, Wright Air Development Center, May 1958. [8]
- Holahan, C. J.**, "Experimental investigations of environment behavior relationships in psychiatric facilities." *Man-Environment Systems*, 1974, 4(2), 109-113. [7,4]
- "Industrial design USA: Human system." *Design Quarterly*, 1973, 88, entire issue. [3]
- Le Corbusier**, *The Modulor*. Cambridge: Harvard University Press, 1954. [1]
- Leibman, M.**, "The effects of sex and race norms on personal space." *Environment and Behavior*, December 1970, 2(2), 208-246. [7]
- Lewin, K.**, *A Dynamic Theory of Personality*. New York: McGraw-Hill, 1935. [2,6]
- Man Is The Measure: The Human Element in Design*, (Design seminar sponsored by the American Iron and Steel Institute). [2]
- Moreno, J. L.**, *Who Shall Survive? Foundations of Sociometry, Group Psychotherapy, and Sociodrama*. New York: Beacon House, 1953. [2]
- Moreno, J. L.**, *Sociometry and the Science of Man*. New York: Beacon House, 1956. [2]
- Pastalan, L. A.**, *The Simulation of Age Related Sensory Losses: A New Approach to the Study of Environmental Barriers*. (Reprint from author). Ann Arbor: University of Michigan. [7]
- Pastalan, L. A.**, "Involuntary environmental relocation: Death and survival." In W. F. E. Preiser (Ed.), *Environmental Design Research: Proceedings of the 4th Annual Environmental Design Research Association Conference* (Vol. 2: Symposia and Workshops). Stroudsburg, Pa.: Dowden, Hutchinson & Ross, 1973. [7,4]

## CHAPTER 7. MAN

- Anastasi, A.**, *Psychological Testing* (4th ed.). New York: Macmillan, 1976. [2]
- Anderson, J., & Tindall, M.**, "The concept of home range: New data for the study of territorial behavior." In W. J. Mitchell (Ed.), *Environmental Design: Research and Practice*, Proceedings of the EDRA 3/AR 8 Conference. Los Angeles: University of California at Los Angeles, 1972. [7,4]
- Baum, A., & Davis, G. E.**, "Spatial and social aspects of crowding perception." *Environment and Behavior*, December 1976, 8(4). [7]
- Calhoun, J. B.**, "Population density and social pathology." In L. Duhl (Ed.), *The Urban Condition*. New York: Basic Books, 1963. [7,4]
- Collins et al.**, In F. A. Geldard, *The Human Senses* (2nd Ed.) New York: John Wiley & Sons, 1972. [2]

**Pastalan, L. A., & Carson, D. H. (Eds.),** *Spatial Behaviour of Older People*. Ann Arbor: University of Michigan, 1970. [3]

**Rapoport, A.,** *House Form and Culture*. Englewood Cliffs, N.J.: Prentice-Hall, 1969. [2]

**Rapoport, A., & Watson, N.,** "Cultural variability in physical standards." In R. Gutman (Ed.), *People and Buildings*. New York: Basic Books, 1972. [7,4]

**Roebuck, J. A., Kroemer, K. H. E., & Thomson, M. S.,** *Engineering Anthropometry Methods*. New York: John Wiley & Sons, 1975. [2]

**Saegart, S. (Ed.),** *Crowding in Real Environments*. New York: Sage Publications, 1976. [3]

**Sommer, R.,** *Personal Space: The Behavioral Basis of Design*. Englewood Cliffs, N.J.: Prentice-Hall, 1974. [2,6]

**Steinfeld, E. H.,** "Physical planning for increased cross-generation contact." In W. F. E. Preiser (Ed.), *Environmental Design Research: Proceedings of the 4th Annual Environmental Design Research Association Conference* (Vol. 1: Selected Papers). Stroudsburg, Pa.: Dowden, Hutchinson & Ross, 1973. [7,4]

**Wells, B. W. P.,** "The psycho-social influence of building environment: Sociometric findings in large and small office spaces." In R. Gutman (Ed.), *People and Buildings*. New York: Basic Books, 1972. [7,4]

**Williamson, P., Le Resche, L., & Geldzahler, M.,** "Space use and behavior in an open plan school: An ethological study." In W. D. Bliss (Ed.), *Proceedings of the Symposium on Environmental Effects on Behavior*. Bozeman: Montana State University, 1975. [7,4]

## CHAPTER 8. MAN/ENVIRONMENT INTERACTIONS

**Acking, C., & Kuller, R.,** "Presentation and judgement of planned environment and the hypothesis of arousal." In W. F. E. Preiser (Ed.), *Environmental Design Research: Proceedings of the 4th Annual Environmental Design Research Association Conference* (Vol. 1: Selected Papers). Stroudsburg, Pa.: Dowden, Hutchinson & Ross, 1973. [7,4]

*Anatomy for Planners* (Vols. 2-4, R12: 1970). Stockholm: Swedish Institute for Building Research, 1970. [5]

**Berns, T. et al.,** *Causes of Accidents Involving Children in Their Homes or the Immediate Vicinity—A Method Study* (National Swedish Building Research Summaries R66: 1973). Stockholm: Svensk Byggtjanst, 1973. [2]

**Best, G. A.,** "Direction-finding in large buildings." In D. V. Canter (Ed.), *Architectural Psychology: Proceedings of the Conference at Dalandhvi*, University of Strathclyde, U.K., 1969. [7,4]

**Blum, M.,** *Industrial Psychology and its Social Foundations*. New York: Harper Bros., 1949. [2]

**Bonsteel, D.,** "Investigation of a televised image in simulation of architectural space." In G. J. Coates & K. M. Moffett (Eds.), *Response to Environment, Student Publications of the School of Design* (Vol. 18). Raleigh: North Carolina State University, 1969. [7,4]

**Conway, P.,** "Measuring man." *Design and Environment*, Winter 1972, pp.14-23. [7]

**Diffrient, N.,** "Design for humans" (Reprinted from seminar, *Man is the Measure*). New York: American Iron and Steel Institute. [2]

**Diffrient, N.,** "Design with backbone" *Industrial Design*, October 1970, 44-47. [7]

**Fitch, J. M.,** *The Architectural Manipulation of Space, Time, and Gravity*. New York: Columbia University, 1969. [2]

**Grandjean, E.,** *Ergonomics of the Home*. New York: Halsted Press, 1974. [5,2]

**Kira, A.,** *The Bathroom: Criteria for Design*. Ithaca, N. Y.: Cornell University, Center for Housing and Environment Studies, 1966. [1]

**Lerup, L.,** *Mapping Behavior: The Case of Fire*. Berkeley, Cal.: University of Calif., Berkeley, Department of Architecture, December 1975. [7]

**McCormick, E. J.,** *Human Factors in Engineering and Design* (4th ed.). New York: McGraw-Hill, 1976. [2]

**Miller, R.,** *A Method for Man-Machine Task Analysis* (RDO No. 694-44). Wright-Patterson AFB, Ohio: Aero Med Laboratory, Wright Air Development Center, 1953. [7]

**Neutra, R.,** "Accident epidemiology and the design of the residential environment." *Human Factors*, 1972, 14(5), 405-420. [7]

**Pauls, J. L.,** "Movement of people in building evacuations." In D. J. Conway (Ed.), *Human Response to Tall Buildings*. Stroudsburg, Pa.: Dowden, Hutchinson & Ross, 1977. [7,4]

**Preiser, W. F. E.,** *Analysis of Pedestrian Velocity and Stationary Behavior in a Shopping Mall*. Blacksburg, Va.: Virginia Polytechnic Institute, Environmental Systems Laboratories, 1973. [2]

**Rubin, A. I., & Cohen, A.,** *Occupant Behavior in Building Fires* (Technical Note 88). Washington, D.C.: National Bureau of Standards, February 1974. [7]

**Sheridan, J. A.,** "Designing the work environment." In W. D. Bliss (Ed.), *Proceedings of the Symposium on Environmental Effects on Behavior*. Bozeman: Montana State University, 1975. [7,4]



- Stillitz, I. B.**, "Pedestrian congestion." In D. V. Canter (Ed.), *Architectural Psychology: Proceedings of the Conference at Dalandhvi, University of Strathclyde, U.K.*, 1969. [7,4]
- Suchman, E. A.**, "A conceptual analysis of the accident phenomena." In *Behavioral Approaches to Accident Research*. New York: Association for Aid to Crippled Children, 1961. [2]
- Ward, J. S., & Kirk, N. S.**, "The relation between some anthropometric dimensions and preferred working surface heights in the kitchen." *Ergonomics*, 1970, 13(6), 783-797. [7]
- Winkel, G. H., & Sasanoff, R.**, "An approach to an objective analysis of behavior in architectural space." In H. M. Proshansky, W. H. Ittleson & L. G. Rivlin (Eds.), *Environmental Psychology: Man and His Physical Setting*. New York: Holt, Rinehart & Winston, 1970. [7,4]

## CHAPTER 9. THE MAN-MADE ENVIRONMENT

- Blake, R. R. et al.**, "Housing, architecture and social interaction." *Sociometry*, 1956, 19, 133-139. [7]
- Boyce, P. R.**, "Users' assessments of a landscaped office." *Journal of Architectural Research*, 1974, 3(3), 44-62. [7]
- Brookes, M. J.**, "Changes in employee attitudes and work practices in an office landscape." In W. J. Mitchell (Ed.), *Environmental Design: Research and Practice, Proceedings of the EDRA 3/AR 8 Conference*. Los Angeles, Calif.: University of Calif., 1972. [7,4]
- Coates, G., & Sanoff, H.** "Behavioral mapping: The ecology of child behavior in a planned residential setting." In W. J. Mitchell (Ed.), *Environmental Design: Research and Practice, Proceedings of the EDRA 3/AR 8 Conference*. Los Angeles, Calif.: University of Calif., 1972. [7,4]
- Collins, B.**, *Windows and People: A Literature Survey* (Building Science Series Report No. 70). Washington, D.C.: National Bureau of Standards, 1975. [7,8]
- Conway, D. J.**, *Human Response to Tall Buildings*. Stroudsburg, Pa.: Dowden, Hutchinson & Ross, 1977. [3]
- Davls, G., & Rolzen, R.**, "Architectural determinants of student satisfaction in college residence halls." In J. Archea & C. Eastman (Eds.), *EDRA 2: Proceedings of the 2nd Annual Environmental Design Research Association Conference*. Pittsburgh, Pa.: Carnegie-Mellon University, October 1970. [7,4]
- Durlak, J. T., Beardsley, B. E., & Murray, J. S.**, "Observations of user activity patterns in open and traditional plan school environments." In W. J. Mitchell (Ed.), *Environmental Design: Research and Practice, Proceedings of the EDRA 3/AR 8 Conference*. Los Angeles, Calif.: University of Calif., 1972. [7,4]
- Egolf, B., & Herrenkohl, R. C.**, "The influence of familiarity and age factors on responses to residential structures." In D. J. Conway (Ed.), *Human Response to Tall Buildings*. Stroudsburg, Pa.: Dowden, Hutchinson & Ross, 1977. [7,3]
- Englund, M., & Hallberg, G.**, *Video Tape Techniques in Full-Scale Tests* (National Swedish Building Research Document D3:1973), 1973. [7]
- Festinger, L.**, "Architecture and group membership." In R. Gutman (Ed.), *People and Buildings*. New York: Basic Books, 1972. [7,4]
- Festinger, L., Schachter, S., & Black, K.**, *Social Pressures in Informal Groups: A Study of Human Factors In Housing*. Stanford, Calif.: Stanford University Press, 1963. [7]
- Fltch, J. M.**, *The Architectural Manipulation of Space, Time, and Gravity*. New York: Columbia University, 1969. [2]
- Fltch, J. M., Templer, J., & Corcoran, P.**, "The dimensions of stairs." *Scientific American*, 1974, 231(4). [7]
- Fried, M., & Gleicher, P.**, "Some sources of residential satisfaction in an urban slum." In H. M. Proshansky, W. H. Ittleson & L. G. Rivlin (Eds.), *Environmental Psychology: Man and His Physical Setting*. New York: Holt, Rinehart & Winston, 1970. [7,4]
- Gans, H. J.**, "Planning and social life: Friendship and neighbor relations in suburban communities." In H. M. Proshansky, W. H. Ittleson & L. G. Rivlin (Eds.), *Environmental Psychology: Man and His Physical Setting*. New York: Holt, Rinehart & Winston, 1970. [7,4]
- Gelb, P. M.**, "High-rise impact on city and neighborhood livability." In D. J. Conway (Ed.), *Human Response to Tall Buildings*. Stroudsburg, Pa.: Dowden, Hutchinson & Ross, 1977. [7,3]
- Hall, E. T.**, "Environmental communication." In A. H. Esser (Ed.), *International Symposium on the Use of Space by Animals and Men*. Dallas, Texas, 1968. [3]
- Hartford, B., & Keleman, K. S.**, "Nurse behavior and nursing unit design." In W. D. Bliss (Ed.), *Proceedings of the Symposium on Environmental Effects on Behavior*. Bozeman: Montana State University, 1975. [7,4]
- Imamoglu, V., & Markus, T. A.**, "The effect of window size, room proportion and window position on spaciousness evaluation of rooms." In *Proceedings of CIE Conference on Windows and Their Function in Architectural Design*, Istanbul, October 1973. [7,3]

**Inui, M., & Miyata, T.,** "Spaciousness in interiors." *Lighting Research and Technology*, 1973, 5, 103-111. [7]

**Keighley, E. C.,** "Visual requirements and reduced fenestration in office buildings—A study of window shape." *Journal of Building Science*, 1973, 8, 311-320. [7]

**Keighley, E. C.,** "Visual requirements and reduced fenestration in offices—A study of multiple apertures and window area." *Journal of Building Science*, 1973, 8, 321-331. [7]

**Kleeman, W.,** "Behavioral change on ward 8." In W. D. Bliss (Ed.), *Proceedings of the Symposium on Environmental Effects on Behavior*. Bozeman: Montana State University, 1975. [7,4]

**Lynch, K.,** *The Image of the City*. Cambridge, Mass.: Harvard University Press, 1960. [2,6]

**Maslow, A. H.,** *Motivation and Personality*. New York: Harper, 1954. [2]

**Maslow, A. H., & Mintz, N. L.,** "Effects of esthetic surroundings: I. Initial short-term effects of three esthetic conditions upon perceiving "energy" and "well-being" in faces." In R. Gutman (Ed.), *People and Buildings*. New York: Basic Books, 1972. [7,4]

**Mintz, N. L.,** "Effects of esthetic surroundings: II. Prolonged and repeated experience in a "beautiful" and an "ugly" room." In R. Gutman, *People and Buildings*. New York: Basic Books, 1972. [7,4]

**Ne'eman, E., & Hopkinson, R. G.,** "Critical minimum acceptable window size: A study of window design and provision of a view." *Lighting Research and Technology*, 1970, 2, 17-27. [7]

**Pile, John F.,** "The open office: Does it work?" *Progressive Architecture*, June 1977, 68-81. [7]

**Porteous, C. W., & Porteous J. D.,** "The learning environment: Enrichment or impoverishment?" In W. D. Bliss (Ed.), *Proceedings of the Symposium on Environmental Effects on Behavior*. Bozeman: Montana State University, 1975. [7,4]

**Riemer, S., & Demerath, N. J.,** "The role of social research in housing design." *Land Economics*, 1952, 28(3), 230-243. [7]

**Savinar, J.,** "The effect of ceiling height on personal space." *Man-Environment Systems*, 1975, 5. [7]

**Schorr, A. L.,** *Slums and Social Insecurity* (Research Report No. 1). Washington, D.C.: U.S. Dept. of HEW, Social Security Administration, 1966. [2]

**Sommer, R.,** *Tight Spaces: Hard Architecture and How to Humanize It*. Englewood Cliffs, N.J.: Prentice-Hall, 1974. [2,6]

**Vigler, F. C.,** "An experimental approach to urban design." *Journal of the American Institute of Planners*, February 1965, 31(1), 21-31. [7]

"Watch your step." *Dimensions/NBS*, November 1974, pp. 252-254. [1]

## CHAPTER 10. THE AUDITORY ENVIRONMENT

**Beraneck, L.,** In C. Harris (Ed.), *Handbook of Noise Control*. New York: McGraw-Hill, 1957. [4]

**Cavanaugh, W. et al.,** "Speech privacy in buildings." *Journal of the Acoustical Society of America*, 1962, 36(4). [7]

**Clark, D. M.,** "Subjective study of the sound-transmission class system for rating building partitions." *Journal of the Acoustical Society of America*, 1970, 47(3), 676-682. [7]

**Fidell, S., Jones, G., & Pearson, K. S.,** *Feasibility of a Novel Technique for Assessing Noise-Induced Annoyance*, (DOT Pub. DOT-TST-74-3). Washington, D.C.: Department of Transportation, September 1973. [7]

**Fletcher, H., & Munson, W.,** In J. D. Harris, *Forty Germinal Papers in Human Hearing*. Groton, Conn.: Journal of Auditory Research, 1969. [3,7]

**Geber, W. F., Anderson, T. A., & Van Dyne, B.,** "Physiologic responses of the albino rat to chronic noise stress." *Archives of Environmental Health*, June 1966, 12, 751-754. [7]

**Griffiths, I. D., & Langdon, F. J.,** "Subjective response to road traffic noise." *Journal of Sound and Vibration*, 1968, 8(1), 16-32. [7]

**Harris, J. D.,** *Forty Germinal Papers in Human Hearing*. Groton, Conn.: Journal of Auditory Research, 1969. [3]

**Kryter, K.,** "Scaling human reactions to the sound from aircraft." *Journal of the Acoustical Society of America*, 1959, 31(11), 1415-1429. [7]

**Kryter, K.,** *The Effects of Noise on Man*. New York: Academic Press, 1970. [2]

**Kryter, K., Johnson, P. J., & Young, J. R.,** *Judgement Tests of Flyover Noise from Various Aircraft* (NASA CR-1635). Washington, D.C.: National Aeronautics and Space Administration, August 1970. [7]

**Peterson, A. P. G., & Gross, E. E., Jr.,** *Handbook of Noise Measurement*. Concord, Mass.: General Radio, 1972. [5]

**Schultz, T. J.,** *Noise Assessment Guidelines Technical Background* (HUD Report No. TE/NA 172). Washington, D.C.: U.S. Government Printing Office, 1972. [2]

**Schultz, T. J., & McMahon, N. M.,** *HUD Noise Assessment Guidelines*. Washington, D.C.: U.S. Government Printing Office, 1971. [2]



- Stevens, S. S.**, *Psychophysics*. New York: John Wiley & Sons, 1975. [2]
- Welch, B. L., & Welch, A. S.**, *Physiological Effects of Noise*. New York: Plenum Press, 1970. [2]
- Yaniv, S., & Flynn, D.**, *Noise Criteria for Buildings: A Critical Review* (NBS Special Publication 499). Washington, D.C.: National Bureau of Standards, Jan. 1978. [7]

## CHAPTER 11. VISUAL PERCEPTION

- Beardslee, D. C., & Wertheimer, M., (Eds.)**, *Readings in Perception*. Princeton, N.J.: Van Nostrand, 1958. [3]
- Carr, S., & Schissler, D.**, "The city as a trip." *Environment and Behavior*, June 1969, 1(1), 7-35. [7]
- Garling, T.**, "The relation of judged depth to judged size of space under different viewing conditions." In S. Hesselgren, *Experimental Studies on Architectural Perception*. National Swedish Building Research Document D2, 1971. [7]
- Gibson, E., & Walk, R.**, In J. E. Hochberg, *Perception*. Englewood Cliffs, New Jersey: Prentice-Hall, 1964. [2]
- Gibson, J. J.**, *The Perception of the Visual World*. Cambridge, Mass.: Riverside Press, 1950. [2,6]
- Heath, T. F.**, "Problems of measurement in environment aesthetics." *Architectural Science Review*, March 1968, pp. 17-28. [7]
- Henle, M.**, *The Selected Papers of Wolfgang Kohler*. New York: Liveright, 1971. [2,6]
- Hochberg, J. E.**, *Perception*. Englewood Cliffs, New Jersey: Prentice-Hall, 1964. [2]
- Ittleson, W., & Kilpatrick, F.**, In J. E. Hochberg, *Perception*. Englewood Cliffs, New Jersey: Prentice-Hall, 1964. [2]
- Katz, D.**, In D. C. Beardslee & M. Wertheimer (Eds.), *Readings in Perception*. Princeton, New Jersey: Van Nostrand, 1958. [3]
- Koffka, K.**, *Principles of Gestalt Psychology*. New York: Harcourt, 1935. [2]
- Kohler, W.**, *Gestalt Psychology*. New York: Liveright, 1947. [2,6]
- Lucklesh, M.**, *Visual Illusions, Their Causes, Characteristics and Applications*. New York: Dover Publications, 1965. [1]
- Mowatt, M.**, In D. C. Beardslee and M. Wertheimer (Eds.), *Readings in Perception*. Princeton, New Jersey: Van Nostrand, 1958. [7,3]

- Murch, G. M.**, *Visual and Auditory Perception*. New York: Bobbs-Merrill, 1973. [2,6]
- Pickett, R. M.**, *Perceiving Visual Texture: A Literature Survey* (AMRL-TR-68-12). Dayton, Ohio: Wright-Patterson Air Force Base, Aerospace Medical Research Laboratories, March 1968. [2,8]
- Rubin, E.**, In D. C. Beardslee & M. Wertheimer (Eds.), *Readings in Perception*. Princeton, New Jersey: Van Nostrand, 1958. [7,3]
- Valentine, C. W.**, *The Experimental Psychology of Beauty*. London: Associated Book Publishers, 1968. [2]
- Vernon, M. D.**, *Experiments in Visual Perception*. Baltimore, Md.: Penguin Books, 1966. [2]
- Wertheimer, M.**, In D. C. Beardslee & M. Wertheimer (Eds.), *Readings in Perception*. Princeton, New Jersey: Van Nostrand, 1958. [7,3]
- Yarbus, A. L.**, *Eye Movements and Vision*. New York: Plenum Press, 1967. [2]

## CHAPTER 12. THE VISUAL ENVIRONMENT—ILLUMINATION

- Blackwell, H. R.**, "Specification of interior illumination levels." *Illuminating Engineering*, 1959, 54(6), 317-353. [7]
- Blackwell, H. R.**, "The evaluation of interior lighting on the basis of visual criteria." *Applied Optics*, 1967, 6(9), 1443-1467. [7]
- Bodmann, H.**, In R. G. Hopkinson & J. B. Collins, *The Ergonomics of Lighting*. London: MacDonald, 1970. [2]
- Boynton, R. M.**, "Some visual factors in reducing lighting levels." In D. K. Ross (Ed.), *The Basis for Effective Management of Lighting*. Washington, D.C.: Federal Energy Administration, October 1975. [7]
- British Illuminating Engineering Society**, "Artificial lighting." *The Architects' Journal Information Library*, January 1967, 13-36. [7]
- Collins, J.**, In R. G. Hopkinson & J. B. Collins, *The Ergonomics of Lighting*. London: MacDonald, 1970. [2]
- Faulkner, W.**, *Architecture and Color*. New York: John Wiley & Sons, 1972. [1]
- Flynn, J. E. et al.**, "Interim study of procedures for investigating the effect of light on impression and behavior." *Journal of IES*, October 1973, 3(1). [7]
- Gilbert, M., & Hopkinson, R. G.**, In R. G. Hopkinson & J. B. Collins, *The Ergonomics of Lighting*. London: MacDonald, 1970. [2]
- Holmes, J. G.**, *Essays on Lighting*. New York: Crane, Russak & Co., 1974. [2]

- Hopkinson, R. G., & Collins, J. B.,** *The Ergonomics of Lighting*. London: MacDonald, 1970. [2]
- IES Lighting Handbook* (5th ed.). New York: Illuminating Engineering Society, 1972. [5]
- Lam, W. M. C.,** "Lighting for architecture." (Reprinted from *Architectural Record*, undated.) [1]
- Lythgoe, R.,** In R. G. Hopkinson & J. B. Collins, *The Ergonomics of Lighting*. London: MacDonald, 1970. [2]
- Neenan, C. J.,** "Shadow characteristics of stage lights for theatre, television and motion pictures." *Illuminating Engineering*, 1968, 63(6), 321-326. [7]
- Ostberg, O., & Stone, P.,** "Methods for evaluating discomfort glare aspects of lighting." *Goteborg Psychological Reports*, Univ. of Goteborg, Sweden, 1974, 4(4). [7]
- Ribiero, J. S., Allen, W. A., & Deamorim, M.,** "Lighting of the Calouste Gulbenkian Museum." *Lighting Research and Technology*, 1971, 3(2). [7]
- Weston, M.,** In R. G. Hopkinson & J. B. Collins, *The Ergonomics of Lighting*. London: MacDonald, 1970. [2]
- Yonemura, G., & Kohayakawa, Y.,** *A New Look at the Research Basis for Lighting Level Recommendations* (NBS Building Science Series 82). Washington, D.C.: National Bureau of Standards, March 1976. [7]

## CHAPTER 13. COLOR

- Acking, C. A., & Kuller, R.,** "The perception of interior as a function of colour." *Ergonomics*, 1972, 15(6), 645-654. [7]
- Ashton, S. M., & Bellchambers, H. E.,** "Illumination, colour rendering and visual clarity." *Lighting Research and Technology*, 1969, 1(4), 259-261. [7]
- Berglund, E.,** *Application of the Natural Colour System*. Stockholm: Swedish Colour Centre Foundation. [7]
- Billmeyer, F. W., & Saltzman, M.,** *Principles of Color Technology*. New York: John Wiley & Sons, 1966. [1]
- Birren, F.,** *Light, Color and Environment*. New York: Van Nostrand, 1969. [1]
- Burnham, R. W., Hanes, R. M., & Bartleson, C. J.,** *Color: A Guide to Basic Facts and Concepts*. New York: John Wiley & Sons, 1963. [2]
- Evans, R. M.,** *An Introduction to Color*. New York: John Wiley & Sons, 1948. [2]

- Faulkner, W.,** *Architecture and Color*. New York: John Wiley & Sons, 1972. [1]
- Hard, A.,** "NCS: A descriptive colour order and scaling system with application for environmental design." *Man-Environment Systems*, 1975, 5(3). [7]
- Hunter, R. S.,** *The Measurement of Appearance*. New York: John Wiley & Sons, 1975. [2]
- Inui, M.,** *Practical Analysis of Interior Color Environment* (BRI Occasional Report No. 27). Tokyo: Building Research Institute, Ministry of Construction, July 1966. [7]
- Judd, D. B.,** "Choosing pleasant color combinations." *Lighting Design and Application*, August 1971, 1(3). [7]
- Judd, D. B.,** *Color in Our Everyday Lives* (NBS Consumer Guide Series 6). Washington, D.C.: National Bureau of Standards, March 1975. [1]
- Judd, D. B., & Kelly, K. L.,** *Color-Universal Language and Dictionary of Names* (NBS Special Publication 440). Washington, D.C.: National Bureau of Standards, December 1976. [7]
- Judd, D. B., & Nickerson, D.,** "Relation between Munsell and Swedish natural color system scales." *Journal of the Optical Society of America*, Jan. 1975, 65(1). [7]
- Judd, D. B., & Wyszecki, G.,** *Color in Business, Science and Industry* (3rd ed.). New York: John Wiley & Sons, 1975. [2]
- Kelly, K. L.,** In D. B. Judd & K. L. Kelly, *Color—Universal Language and Dictionary of Names* (NBS Special Publication 440). Washington, D.C.: National Bureau of Standards, December 1976. [7]
- Kuller, R.,** *The Perception of an Interior as a Function of its Colour* (Report 1). Lund, Sweden: Lund Institute of Technology, Section of Architecture, 1969. [7]
- Nimeroff, I. (Ed.),** *Precision Measurement and Calibration* (NBS Special Publication 300, Vol. 9, Colorimetry). Washington, D.C.: National Bureau of Standards, June 1972. [4]
- Payne, I.,** "Pupillary response to architectural stimuli." In D. V. Canter (Ed.), *Architectural Psychology: Proceedings of the Conference at Dalandhvi*, University of Strathclyde, U.K., 1969. [7,4]
- Srivastava, R. K., & Peel, T. S.,** *Human Movement as a Function of Color Stimulation*. Topeka, Kan.: Environmental Research Foundation, 1968. [7]
- Wright, W. D.,** *The Measurement of Color*. London: Hilger & Watts, 1958. [2]



## CHAPTER 14. THE THERMAL ENVIRONMENT

**Acking, C. A., & Kuller, R.,** *Factors in the Perception of the Human Environment: Semantic Ratings of Interiors from Colour Slides.* Lund, Sweden: Lund Institute of Technology, Department of Theoretical and Applied Aesthetics, 1967. [7]

**Acking, C. A., & Kuller, R.,** "The perception of an interior as a function of its colour." *Ergonomics*, 1972, 15, 645-654. [7]

**American Society of Heating, Refrigerating and Air-Conditioning Engineers,** *ASHRAE Handbook of Fundamentals.* New York: ASHRAE, 1972. [2,5]

**Bruce, W.,** *Man and His Thermal Environment* (Division of Building Research Technical Paper 84). Ottawa: NRC-DBR, Feb. 1960. [2,8]

**Canter, D. V., & Stringer, P.,** *Environmental Interaction—Psychological Approaches to Our Physical Surroundings.* London: Surrey University Press, 1975. [1]

**Fanger, P. O.,** *Thermal Comfort.* Copenhagen: Danish Technical Press, 1970. [2,6]

**Fanger, P. O., & Griffiths, I.,** In P. O. Fanger, *Thermal Comfort.* Copenhagen: Danish Technical Press, 1970. [2]

**Fanger, P. O., & Olesen, B.,** In P. O. Fanger, *Thermal Comfort.* Copenhagen: Danish Technical Press, 1970. [2]

**Fitch, J. M.,** *The Architectural Manipulation of Space, Time, and Gravity.* New York: Columbia University, 1969. [2]

**Hardy, J. D.,** In J. D. Hardy, A. P. Gagge & J. A. Stolwijk (Eds.), *Thermal Comfort, Physiological and Behavioral Temperature Regulation.* Springfield, Illinois: Chas. Thomas, 1970. [3,7]

**Holmberg, I., & Wyon, D.,** In *Thermal Comfort and Moderate Heat Stress* (BRE Report 2). Garston, Watford, U.K.: HMSO, 1973. [7]

**Houghton, F. C., & Yagloglou, C. P.,** "Determination of the comfort zone." *ASHVE Transactions*, 1923, 29. [7]

**Humphreys, M. A.,** *Clothing and Thermal Comfort of Secondary School Children* (CIB Commission W45). Symposium on Thermal Comfort and Moderate Heat Stress, September, 1972. [7]

**Humphreys, M. A., & Nicol, J. F.,** *Theoretical and Practical Aspects of Thermal Comfort* (BRS CP 14/71). Garston, Watford, U.K.: Building Research Station, April 1971. [7]

**Jones, R. D.,** *Effect of Thermal Stress on Human Performance: A Review and Critique of Existing Methodology* (Tech. Memo 11-70). Aberdeen, Md: Human Engineering Laboratories, 1970. [2,8]

**Langdon, F. J.,** "Human sciences and the environment in buildings." *Build International*, Jan.-Feb. 1973, 6(1). [7]

**Langdon, F. J., & Loudon, A.,** "Discomfort in schools from overheating in summer." *Journal of the Institution of Heating and Ventilation Engineers*, March 1970, 37, 265-274. [7]

**Mangum, D. W., & Hill, J. E.,** *Thermal Analysis—Human Comfort—Indoor Environments* (NBS Special Publication 491). Washington, D.C.: National Bureau of Standards, Sept. 1977. [3]

**McIntyre, D.,** In *Thermal Comfort and Moderate Heat Stress* (BRE Report 2). Garston, Watford, U.K.: HMSO, 1973. [7]

**McNall, P. et al.,** "The relative effects of convection and radiation heat transfer on thermal comfort for sedentary and active human subjects." *ASHRAE Transactions*, 1968, 74 (Part II), 131-143. [7]

**Newton, A. et al.,** In F. C. Houghton, C. Gutbercet & A. Rosenberg, *Summer cooling requirements in Washington, D.C. and other metropolitan districts.* *ASHVE Transactions*, 1939, 45(577). [7]

**Rohles, F. H.,** "Psychological aspects of thermal comfort." *ASHRAE Journal*, January 1971, 86-90. [7]

**Ryd, H., & Wyon, D.,** *Methods of Evaluating Human Stress Due to Climate* (National Swedish Building Research Report D6:1970). Stockholm, 1970. [7]

**Teichner, W. H.,** "The subjective response to the thermal environment." *Human Factors*, 1967, 9(5), 497-510. [7]

*Thermal Comfort and Moderate Heat Stress* (BRE Report 2). Garston, Watford, U.K.: HMSO, 1973. [7]

**Wyon, D. P., Asgeirsdettir, T., Kjerulf-Jensen, P., & Fanger, P. O.,** "The effects of ambient temperature swings on comfort, performance and behavior." *Proceedings of Conference on Prediction of Thermal Environment in Man*, Strasbourg, France, July 1973. [7]

## CHAPTER 15. THE OLFACTORY ENVIRONMENT—AIR QUALITY

**American Society for Testing and Materials.** *Correlation of Subjective-Objective Methods in the Study of Odors and Taste* (Special Tech. Pub. ASTM 440). Philadelphia: ASTM, June 1968. [2]

**Elsberg, C., & Levy, I.,** In D. G. Moulton, A. Turk & J. W. Johnston (Eds.), *Methods in Olfactory Research.* New York: Academic Press, 1975. [3]

**McCord, C. P., & Witheridge, W. N.,** *Odors, Physiology and Control*. New York: McGraw-Hill, 1949. [2]

**Miner, R. W.,** "Basic odor research correlation." *Annals of the N.Y. Academy of Sciences*, March 1954, 58, art. 2. [3]

**Moulton, D. G., Turk, A., & Johnston, J. W.,** *Methods in Olfactory Research*. New York: Academic Press, 1975. [3]

**Springer, K. J., & Hare, C. T.,** *A Field Study to Determine Public Opinion of Diesel Engine Exhaust Odor* (Rep. AR-718). San Antonio, Texas: Southwest Research Institute, February 1970. [7]

**Turk, A.,** In D. G. Moulton, A. Turk & J. W. Johnston (Eds.), *Methods in Olfactory Research*. New York: Academic Press, 1975. [3]

**Turk, A., & Mehlman, S.,** In D. G. Moulton, A. Turk & J. W. Johnston (Eds.), *Methods in Olfactory Research*. New York: Academic Press, 1975. [3]

**Wittes, J., & Turk, A.,** In D. G. Moulton, A. Turk & J. W. Johnston (Eds.), *Methods in Olfactory Research*. New York: Academic Press, 1975. [3]

## CHAPTER 16. ENVIRONMENTAL STABILITY—MOVEMENTS

**Allen, D.L., & Swallow, J.L.,** "Annoying floor vibrations—diagnosis and therapy." *Journal of Sound and Vibration*, 1975. [7]

**Bender, E. K., & Collins, A. M.,** *Effects of Vibration on Human Performance: A Literature Review* (Bolt, Beranek and Newman Report 1767). Boston: Bolt, Beranek and Newman, February 1969. [2,8]

**Chen, P. W., & Robertson, F.,** "Human perception thresholds of horizontal motion." *Journal of Structural Division*, Proceedings of ASCE, August 1972. [7]

**Dennis, J.,** In E. K. Bender & A. M. Collins, *Effects of Vibration on Human Performance: A Literature Review* (Bolt, Beranek and Newman Report 1767). Boston: Bolt, Beranek and Newman, Feb. 1969. [2,8]

**Helberg, W., & Sperling, E.,** In W. Bryce, *A Review and Assessment of Criteria for Human Comfort of Vibration* (N.G.T.E. R286). Pyestock, Hants, U.K.: Ministry of Aviation, National Gas Turbine Establishment, Dec. 1966. [2,8]

**Holland, C. et al.,** In E. K. Bender & A. M. Collins, *Effects of Vibration on Human Performance: A Literature Review* (Bolt, Beranek and Newman Report 1767). Boston: Bolt, Beranek and Newman, Feb. 1969. [8]

**Hornick, R.,** In E. K. Bender & A. M. Collins, *Effects of Vibration on Human Performance: A Literature Review* (Bolt, Beranek and Newman Report 1767). Boston: Bolt, Beranek and Newman, Feb. 1969. [8]

**Irwin, A. W.,** "Human reactions to oscillations of buildings—acceptable limits." *Build International*, 1975, 8(2). [7]

**Jacklin, H., & Lidell, G.,** In E. K. Bender & A. M. Collins, *Effects of Vibration on Human Performance: A Literature Review* (Bolt, Beranek and Newman Report 1767). Boston: Bolt, Beranek and Newman, Feb. 1969. [8]

**Parks, D. L., & Snyder, F. W.,** *Human Reaction to Low Frequency Vibration* (Tech. Rep. D3-3512-1). Wichita, Kansas: Boeing Co., July 1961. [7]

**Reed, J. W.,** *Wind-Induced Motion and Human Discomfort in Tall Buildings* (Research Report R71-42). Cambridge, Mass.: Massachusetts Institute of Technology, Department of Civil Engineering, November, 1971. [7]

**Reiher, H., & Meister, F.,** In W. Bryce, *A Review and Assessment of Criteria for Human Comfort of Vibration* (N.G.T.E. R286). Pyestock, Hants, U.K.: Ministry of Aviation, National Gas Turbine Establishment, Dec. 1966. [8]

**Schmitz, M.,** In E. K. Bender & A. M. Collins, *Effects of Vibration On Human Performance: A Literature Review* (Bolt, Beranek and Newman Report 1767). Boston: Bolt, Beranek and Newman, Feb. 1969. [8]

**Van Deusen,** In E. K. Bender & A. M. Collins, *Effects of Vibration on Human Performance: A Literature Review* (Bolt, Beranek and Newman Report 1767). Boston: Bolt, Beranek and Newman, Feb. 1969. [8]

**Weisz, A. et al.,** In E. K. Bender & A. M. Collins, *Effects of Vibration on Human Performance: A Literature Review* (Bolt, Beranek and Newman Report 1767). Boston: Bolt, Beranek and Newman, Feb. 1969. [8]

**Yamada, M., & Goto, T.,** "Human response to tall building motion." In D. Conway (Ed.), *Human Response to Tall Buildings*. Stroudsburg, Pa.: Dowden, Hutchinson & Ross, 1977. [3,7]

## CHAPTER 17. THE CUTANEOUS ENVIRONMENT—SKIN SENSES

**Austin, T., & Sleight, R.,** In C. H. Baker & R. J. Hall, *Cutaneous Sensitivity: A Review of Some Literature, Problems, and Approaches* (U.S. Army Tech. Memo 21-69). Aberdeen, Md.: Human Engineering Laboratories, Dec. 1969. [8]

**Bach Y Rita et al.,** In F. A. Geldard, *The Human Senses* (2nd ed.). New York: John Wiley & Sons, 1972. [2]

**Baker, C. H., & Hall, R. J.,** *Cutaneous Sensitivity: A Review of Some Literature, Problems and Approaches* (U.S. Army Tech. Memo 21-69). Aberdeen, Md.: Human Engineering Laboratories, Dec. 1969. [8]



**Burnham, C. A., & Grim, C. T.,** *Toward a Rational Aesthetic Criterion for the Selection of the Visual Properties of Architectural Surfaces.* Paper presented at the 7th Annual Architectural Research Conference, University of Cinn., Nov. 1970. [7]

**Burrows, A., & Cummings, F.,** In C. H. Baker & R. J. Hall, *Cutaneous Sensitivity: A Review of Some Literature, Problems and Approaches* (U. S. Army Tech. Memo 21-69). Aberdeen, Md.: Human Engineering Laboratories, Dec. 1969. [8]

**Geldard, F. A.,** *The Human Senses* (2nd ed.). New York: John Wiley & Sons, 1972. [2]

**Gillner, C.,** "Tactual discrimination thresholds for shape and texture in young children." *Journal of Experimental Child Psychology*, 1967, 5, 536-547. [7]

**Hawkes, G.,** *Absolute Identification of Cutaneous Stimuli* (FAA Report 62-16). Washington, D.C.: Federal Aviation Administration, Sept. 1962. [7]

**Katz, D.,** In D. C. Beardslee & M. Wertheimer (Eds.), *Readings in Perception*. Princeton, New Jersey: Van Nostrand, 1958. [7,3]

**McCormick, E. J.,** *Human Factors in Engineering and Design* (4th ed.). New York: McGraw-Hill, 1976. [2]

**Siegel, A., & Vance B.,** "Visual and haptic dimensional preference." *Developmental Psychology*, 1970, 3(2), 264-266. [7]

**Sinclair, D. C.,** *Cutaneous Sensation*. New York: Oxford University Press, 1967. [2]

**Stevens, S. S.,** *Psychophysics*. New York: John Wiley & Sons, 1975. [2]

**Von Frey, M.,** In F. A. Geldard, *The Human Senses* (2nd ed.). New York: John Wiley & Sons, 1972. [2]

**Yoshida, M.,** "Dimensions of tactual impressions." *Psychological Research*. 1968, 10(3), 123-137. [7]

## CHAPTER 18. SUMMARY, CONCLUSIONS, AND DIRECTIONS

**Gropius, W.,** *The New Architecture and the Bauhaus*. London: Faber, 1935. [1]

**Gropius, W.,** *Scope of Total Architecture*. New York: Macmillan, 1970. [1]

**Riemer, S.,** "Livability—A new factor in home value." *The Appraisal Journal*, April 1946, 14(2), 148-158. [7]

**Riemer, S.,** "Hidden dimensions of neighborhood planning." *Land Economics*, May 1950, 26, 197-201. [7]

**Riemer, S., & Demerath, N. J.,** "The role of social research in housing design." *Land Economics*, Aug. 1952, 28(3), 230-243. [7]

**Seligman, C. et al.,** *Psychological Strategies to Reduce Energy Consumption: First Annual Progress Report* (Center for Environmental Studies, Report No. 41). Princeton, New Jersey: Princeton University, 1976. [7]

## CHAPTER 19. BEHAVIORAL RESEARCH—HISTORICAL FACTORS (OVERVIEW)

**Anderson, H. H., & Anderson, G. L.,** *An Introduction to Projective Techniques and Other Devices for Understanding the Dynamics of Human Behavior*. New York: Prentice-Hall, 1951. [2]

**Beardslee, D. C., & Werthelmer, M. C. (Eds.),** *Readings in Perception*. Princeton, New Jersey: Van Nostrand, 1958. [3]

**Blum, M.,** *Industrial Psychology and Its Social Foundations*. New York: Harper Bros., 1949. [2]

**Borling, E.,** *Sensation and Perception in the History of Experimental Psychology*. New York: Appleton, Century-Crofts, 1942. [2]

**Borling, E.,** *A History of Experimental Psychology* (2nd ed.). New York: Appleton, Century-Crofts, 1950. [2]

**Chaplin, J., & Krawlec, T.,** *Systems and Theories of Psychology*. New York: Holt, Rinehart & Winston, 1962. [2]

**Cooper, C. C.,** *Easter Hill Village*. New York: Macmillan, 1975. [2]

**Dennis, W. (Ed.),** *Readings in the History of Psychology*. New York: Appleton, Century-Crofts, 1948. [4]

**Gutman, R. (Ed.),** *People and Buildings*. New York: Basic Books, 1972 [4]

**John B. Pierce Foundation,** *Family Living as the Basis for Dwelling Design*, Vols. 1-5. New York: John B. Pierce Foundation, 1943. [2]

**Kohler, W.,** *Gestalt Psychology*. New York: Mentor Books, 1947. [1]

**Proshansky, H. M., Ittleson, W. H., & Rivlin, L. G. (Eds.),** *Environmental Psychology: Man and His Physical Setting*. New York: Holt, Rinehart & Winston, 1970. [4]

**Reimer, S.,** "Livability—A new factor in home value." *The Appraisal Journal*, April 1946, 14 (2), 148-158. [1]

**Stevens, S. S.,** *Psychophysics*. New York: John Wiley & Sons, 1975. [2]

**Vernon, M. (Ed.),** *Experiments in Visual Perception*. Baltimore, Md.: Penguin Books, 1966. [3]

**Wright, W. D.,** *The Measurement of Color*. London: Hilger & Watts, 1958. [2]

## CHAPTER 20. SURVEYS

**Blankenship, A. B.,** *Consumer and Opinion Research: The Questionnaire Technique*. New York: Harper & Bros., 1943. [1,2]

**Cantril, H.,** *Gauging Public Opinion*. Princeton, New Jersey: Princeton University Press, 1944. [2]

**Edwards, A. L.,** *Techniques of Attitude Scale Construction*. New York: Appleton, Century-Crofts, 1957. [2,6]

**Gallup, G.,** *Qualitative Measurement of Public Opinion: The Quintamensional Plan of Question Design*. Princeton, New Jersey: American Institute of Public Opinion, 1947. [7]

**Glock, C. Y. (Ed.),** *Survey Research in the Social Sciences*. New York: Russell Sage Foundation, 1967. [3]

**Hyman, H.,** *Survey Design and Analysis: Principles, Cases and Procedures*. New York: The Free Press, 1955. [2]

**Langdon, F. J.,** *Modern Offices: A User Survey (National Building Studies Research Paper 41)*. London: HMSO, 1966. [7]

**Langdon, F. J., & Keighley, E. C.,** "User research in office design." *Architects' Journal*, February 5, 1964. [7]

**Lucas, D. B., & Britt, S. H.,** *Advertising Psychology and Research*. New York: McGraw-Hill, 1950. [1]

**Manning, P. B. (Ed.),** *Office Design: A Study of Environment*. University of Liverpool, Department of Building Science, Pilkington Research Unit, 1965. [2,7]

**Nicholls, W. L., II, & Babbie, E. R.,** *Oakland In Transition: A Summary of the 701 Household Survey*. Berkeley, Calif.: University of Calif., Berkeley, Survey Research Center, June 1969. [7]

**Oppenheim, A. N.,** *Questionnaire Design and Attitude Measurement*. New York: Basic Books, 1966. [2]

**Payne, S. L.,** *The Art of Asking Questions*. Princeton, N. J.: Princeton University Press, 1951. [1]

**University of Illinois at Urbana, Committee on Housing Research and Development,** *Families in Public Housing: An Evaluation of Three Residential Environments in Rockford, Illinois*. Champaign, Illinois: Author, 1972. [7]

## CHAPTER 21. CLASSIFICATION, MEASUREMENTS, AND STATISTICS

**Anastasi, A.,** *Psychological Testing* (4th ed.). New York: Macmillan, 1976. [2]

**Arkin, H., & Colton, R. R.,** *Statistical Methods*. New York: Barnes & Noble, 1955. [2]

**Cattell, R. B. (Ed.),** *Handbook of Multivariate Psychology*. Chicago: Rand McNally, 1966. [3]

**Edwards, A. L.,** *Techniques of Attitude Scale Construction*. New York: Appleton, Century-Crofts, 1957. [2]

**Edwards, A. L.,** *Experimental Design in Psychological Research*. New York: Holt, Rinehart & Winston, 1965. [2]

**Garrett, H. E.,** *Statistics in Psychology and Education*. New York: Longmans, Green and Co., 1953. [2]

**Moroney, M.,** *Facts From Figures* (3rd ed.). Baltimore, Md.: Penguin Books, 1956. [1]

**Roebuck, J. A., Kroemer, K. H. E., & Thompson, M. S.,** *Engineering Anthropometry Methods*. New York: John Wiley & Sons, 1975. [2]

**Siegel, S.,** *Nonparametric Statistics*. New York: McGraw-Hill, 1956. [2]

**Skinner, B. F.,** *Science and Human Behavior*. New York: Macmillan, 1953. [2]

**Stevens, S. S.,** *Psychophysics*. New York: John Wiley & Sons, 1975. [2]

**Wilson, E. B.,** *An Introduction to Scientific Research*. New York: McGraw-Hill, 1952. [2]

**Youden, W. J.,** *Risk, Choice and Prediction*. Belmont, Calif.: Wadsworth, 1974. [1]



# Index

## SUBJECT INDEX

Absolute threshold 62  
Accident research 65  
Activities 29, 30  
AI 133  
Analytic (see Research)  
Anechoic chamber 132  
Anthropometry 92, 93, 102, 245  
Applied (see Research)  
Articulation index (see AI)  
Audiogram 140  
Audiometer 140  
Average error (see Psychophysical methods)  
Averages 139  
  mean 246, 272  
  median 272  
  mode 272  
  
Background noise 139  
Basic (see Research)  
Behavior setting 56, 57  
Binomial expansion 27  
  
Chance 269, 271  
Chroma 173  
Classical conditioning 236  
Color  
  film 169  
  surface 169  
  volume 169  
Cones 79, 154  
Constancy phenomena 148, 150  
Constant stimuli (see Psychophysical methods)  
Control setting 75  
Control variable 45

Controls 51, 104, 213  
Correlation 21, 273  
Critical incident 109  
Crowding 90  
  
Dark adaptation 154  
Data 41  
dBA scale 47  
Defensible space 65, 66  
Dependent variable 34, 45, 59  
Dichotomous item 260  
Disability glare (see Glare)  
Discomfort glare (see Glare)  
Displays 104, 213  
  
Ecological psychology 57  
Electromyography 101  
Equal loudness contours 137  
Ergonomics 22  
Errors of first kind 270  
Errors of second kind 270  
Experiment 41  
Experimental setting 75  
Eye movements 59, 146, 147, 150, 234  
  
Figure-ground 149  
Film color (see Color)  
Filter questions 262  
Fixed-feature space 123  
Focused interview 257  
Fovea 154  
  
Galvanic skin response (GSR) 89  
Games (see Simulation)  
Gestalt 148, 149, 233  
Glare 153  
  disability 158  
  discomfort 158, 159  
Gradient 144

Hard architecture 114  
Hawthorne studies 249  
Hodometer 111  
Hue 173  
Hue circle 178  
Human factors 22, 25, 95, 100, 104, 112, 251  
Hypothesis 21, 34, 54  
  
Incident light 164  
Independent variable 34, 45  
Interval scale (see Scale)  
Interviews 256  
  
Just noticeable difference (JND) 237  
  
Landolt ring 161  
Life space 84, 86  
Lightness scale 178  
Literature review 42  
Loudness 137  
  
Mapping 71, 72, 73  
Matched group 90  
Mean (see Average)  
Median (see Average)  
M/E models  
  correlation 55  
  decision 58  
  descriptive 58  
  predictive 58  
  S-O-R (see S-O-R)  
  S-R (see S-R)  
Mode (see Average)  
Movable space feature 122  
Multiple choice 260  
Multiple criterion technique 165  
Multivariate (see Research)  
Munsell Color System 173

Nativistic 233  
Natural Color System 178, 179  
NC curves 130, 133  
Noise 128, 141  
Noise criteria (see NC)  
Nominal scale (see Scale)  
Normal curve 246  
Normal distribution 270, 271  
Null hypothesis 269  
  
Observations 30, 49, 54  
Observer  
  participant 87  
  passive 58  
Olfactometer 200  
Open-ended questions 259  
Operational definition 49, 50  
Ordinal scale (see Scale)  
  
Paired comparison 74, 138, 260  
Panel survey (see Survey)  
Parameter 45, 54  
Parametric research (see Research)  
Participant observer (see Observer)  
Passive observer (see Observer)  
PB word 135  
Peak noise 139  
Pedometer 101  
Perceived noisiness 137  
Performance approach 6, 25, 28, 29  
Performance measures 191, 209  
Permanent threshold shift (see PTS)  
Personal space 87  
Phenomenologist 233  
Phonetically balanced (see PB)  
Photographic (see Simulation)  
Phototropic 154  
Physiological 62, 77, 78, 89, 129, 180, 234, 235  
Pilot study 43, 266

PNC 137  
Population 253, 264  
Prediction survey (see Survey)  
Preferred noise criteria (see PNC)  
Projective techniques 247, 248  
Psychoanalytic 247  
Psychophysical methods 236, 237  
    average error 137, 238  
    constant stimuli 238  
    method of limits 238  
Psychophysics 21, 232  
PTS 139

Questionnaires 49, 51, 115, 116, 193,  
    245, 253  
    mail 258  
    self-administered 258  
    telephone interviews 259

Random sample 265  
Ratio scale (see Scale)  
Relatoscope 112  
Reliability 47, 48, 273  
Research  
    analytic 44, 232  
    applied 41  
    basic 40  
    multivariate 45  
    parametric 45, 47  
Respondents 46

Rhodopsin 45  
Rods 79, 154

Sample 253  
Scale model (see Simulation)  
Scales  
    interval 267  
    ordinal 267  
    nominal 267  
    ratio 267  
SC curves 13  
Scentometer 201  
Scientific approach 34, 39  
Scientific method 21  
Self-actualization 17  
Semantic differential 63, 116  
Semifixed-feature space 117  
Sensations 233  
SIL 131  
Silent language 257  
Simulation 60, 72  
    games 62, 72, 74, 75  
    photographic 48, 71, 75, 76, 111,  
        114, 181  
    scale model 60, 61, 72, 90, 91, 111,  
        120, 121, 123, 181  
Sinusoidal 207  
Snellen eye chart 160, 161  
Social distance 89  
Sociogram 89

Sociometry 89  
Sone 137  
S-O-R 55  
Sound 141  
Sound transmission class (see STC)  
Speech communication (see SC)  
Speech interference level (see SIL)  
Speech intelligibility 134  
S-R 55  
Standard deviation 246, 271  
Standard observer 241  
Standardized research 42, 51  
STC 28, 130, 131  
Stereophotography 102  
Stimulus 55, 257  
Stratified sample 265  
Stoboscope 159  
Subsystem 25  
Suprathreshold 156, 163  
Surface color (see Color)  
Survey designs 255  
    panel 255  
    prediction 255  
    trend 255  
Systematic observation 30, 59, 75,  
    115, 117  
Systems approach 23, 24, 112

Tachistoscope 114, 244  
Task analysis 25, 26

Temporary threshold shift (see TTS)  
Territoriality 87  
Texture gradients 144, 145  
Thermal comfort 186, 188  
Thermal neutrality 186  
Thermography 234  
Time and motion studies 100  
Time budget 26, 64  
TL 132  
TNI 139  
Traffic noise index (see TNI)  
Transient adaptation 155  
Transmission loss (see TL)  
Trend studies (see Survey)  
Triangle test 200  
TTS 139

Universal Color Language 174, 175,  
    176, 177  
Unobtrusive measures 64, 111  
User requirements 13

Validity 47, 48  
Value 173  
Vapor dilution method 200  
Visual acuity 160  
Volume color (see Color)

White noise 141



# AUTHOR INDEX

Aas, D. 57  
Abelson, R. 61  
Abney 241  
Acking, C. 112  
Allen, D. 206  
Allen, W. 155  
Anderson, J. 87  
Anderson, L. 193  
Archea, J. 119  
Arkin 272  
Aston, S. 169  
Astrand, I. 77  
Austin, T. 213  
  
Bach Y Rita 97, 174, 215  
Barker, R. 56, 57  
Barnes 202  
Baum, A. 91  
Beadslee, D. 148  
Bechtel, R. 48, 56, 110  
Beecher, C. 99  
Bell, C. 235  
Bellchambers, H. 169  
Beranek, L. 130, 133  
Berglund, E. 179  
Bernard, C. 39  
Berns, T. 109  
Bessel, F. 245  
Best, G. 110  
Billmeyer, F. 172  
Blackwell, H. 158, 161, 162, 163  
Blackwell, O. 161, 162  
Blake, R. 118  
Blankenship, A. 256, 261  
Bliss, J. 214  
Blondel, F. 119  
Bloomfield, B. 65  
Blum, M. 61, 64  
Bodmann, H. 162  
Bonsteel, D. 111  
Boring, E. 150, 234, 236, 237, 239,  
240, 241, 244  
Boyce, P. 116  
Boynton, R. 155, 158  
Bradley 245

Brentano, F. 244  
Bridgman, P. 49  
Brill, M. 28, 33  
Britt, S. 254, 262  
Broadbent, C. 20  
Broca, P. 235  
Brookes, M. 116  
Burandt, U. 103  
Burrows, A. 215  
Buttolph, L. 162  
  
Calhoun, J. 90, 91  
Candee, B. 61  
Canter, D. 187, 189  
Cantril, H. 260, 261  
Carr, S. 146  
Caudill, W. 19, 29  
Cavanaugh, W. 133  
Chapanis, A. 104  
Chapin, F. 62  
Chen, P. 204  
Clark, D. 132  
Coates, G. 114  
Cohen, A. 106  
Cohn, S. 62  
Collins, J. 62, 97, 159  
Colton 272  
Colucci 202  
Conway, D. 115  
Cooper, C. 33, 251  
Craik, K. 48, 226  
Cronberg, T. 29, 35  
Crook, J. 86  
Crouch, C. 152, 157  
Cummings, F. 215  
  
Dabbs, J. 88  
Dallenbach 216  
Davis, G. 91, 115  
Dempsey, C. 94, 100  
Dennis, J. 209  
Descartes, R. 233  
Dickson, W. 249  
Diffrient, N. 103  
Doxiades, C. 18  
Dreyfuss, H. 95  
Durlak, J. 117  
  
Eberhard, J. 23

Egolf, B. 115  
Elsberg, C. 201  
Englund, M. 117  
Esquirol 245  
Esser, A. 76  
Evans, G. 89  
  
Fanger, P. 187, 188, 190, 191, 195  
Faulkner, W. 168  
Fechner, G. 237, 238  
Festinger, L. 113  
Fidell, S. 133, 138  
Fitch, J. 53, 99, 119, 183  
Fisher, G. 244  
Flanagan, J. 109  
Fletcher, H. 137  
Fluorens, P. 235  
Flynn, D. 130, 131  
Flynn, J. 157  
Freud, S. 84, 232, 247  
Fritsch, G. 235  
Fry, G. 159  
  
Gallup, G. 262  
Galton, F. 92, 245  
Galtung, J. 41  
Garling, T. 145, 146  
Garrett, H. 267  
Gelb, P. 115  
Geldard, F. 215  
Gerbers, C. 202  
Gibson, J. 144, 145  
Giedion, S. 4, 7  
Gilbert, M. 160  
Gilbreth, F. 100  
Gilbreth, L. 100  
Gliner, C. 217  
Glock, C. 253  
Godschalk, D. 72  
Goethe, J. 242  
Goto, T. 204, 205, 209  
Grandjean, E. 77, 96, 103  
Griffiths, I. 139, 195  
Gropius, W. 4, 221  
Gustafson, C. 23  
Guth, S. 159  
Gutman, R. 83, 251

Hackett, P. 33  
Hall, E. 86, 117, 257  
Hall, M. 235  
Hallberg, G. 117  
Hard, A. 178  
Hare, C. 202  
Hartford, B. 115  
Hawkes, G. 214  
Hay, D. 65  
Helberg, W. 207  
Helmholtz, H. 240, 241  
Helson, H. 169  
Henning 199  
Hering, E. 143, 242  
Herrenkohl, R. 115  
Hester, R. 31  
Hewitt 165  
Hitzig, I. 235  
Hobbes, T. 233  
Hochberg, J. 143  
Holahan, C. 88  
Holland, C. 207  
Holmberg, I. 192  
Holmes, J. 152, 153  
Hopkinson, R. 120, 159, 160, 165  
Hornick, R. 209  
Horstman 199  
Houghton, F. 180, 186, 187  
Howard, R. 63, 89  
Humphreys, M. 191, 195  
  
Imagoglu, M. 121  
Inui, M. 121, 181  
Ittleson, W. 30, 75, 76, 147, 148, 251  
  
Jacklin, H. 208  
Jaensch, E. 244  
Johansson, T. 167, 178  
Judd, D. 167, 168, 169, 170, 171, 172,  
173, 178  
  
Katz, D. 169, 217, 218  
Kant, I. 233, 243  
Keighley, E. 120  
Keleman, K. 115  
Kelly, K. 174, 175, 176, 177  
Kilpatrick, F. 147, 148  
Kinnebrook, D. 245

Kira, A. 106  
Kirk, M. 102  
Kleeman, W. 115  
Kliment, S. 19  
Kohler, I. 147  
Kohler, W. 242  
Konig, A. 241  
Kraegel, J. 24  
Kroemer, K. 270  
Kronlund 159  
Kryter, K. 137, 138  
Küller, R. 112, 179, 180

Ladd, F. 72  
Lam, W. 152  
Lambert, J. 240  
Langdon, F. 139, 185, 193  
Lau, J. 61  
Learner, D. 103  
Le Carpentier 103  
Le Courbusier 92, 183  
Leibnitz, G. 233, 243  
Lerup, L. 107, 108  
Levin, P. 33, 34  
Levy, I. 201  
Lewin, K. 84  
Lidell, G. 209  
Liebman, M. 88  
Lindenbaum, L. 104  
Locke, J. 234  
Lotze, R. 233  
Loudon, A. 193  
Lowrey, R. 74  
Lozar, C. 225  
Lucas, D. 254, 262  
Luckiesh, M. 144, 159  
Lynch, K. 42, 71, 75, 114, 248  
Lythgoe, R. 161

Magendie, F. 235  
Malek, R. 61  
Markus, T. 32, 33, 34, 35, 58, 121  
Maskelyne, N. 245  
Maslow, A. 16, 17, 123  
Maxwell, C. 241  
McCormick, E. 44, 213  
McIntyre, D. 193, 194  
McMahon, N. 136

McNall, P. 189, 190  
Mehlman, S. 200  
Melton, A. 110  
Meister, D. 94  
Meister, F. 203  
Michelson, W. 26, 27, 41, 67  
Mill, J. 234  
Mill, J. S. 234, 237  
Miller, R. 26, 101  
Mintz, N. 123  
Miyata, T. 121  
Moreno, J. 89  
Moskowitz 202  
Mowatt, M. 150  
Munsell, A. 167, 173  
Munson, W. 137

Ne'eman, E. 120  
Neenan, C. 164  
Neutra, R. 5  
Nevins, A. 190, 195  
Newhall 177  
Newman, O. 65, 66  
Newton, A. 192  
Newton, I. 167, 239  
Nickerson, D. 178  
Nicol, J. 195  
Nutting, P. 159

Olesen, B. 190, 191, 193  
Oppenheim, A. 255  
Ostberg, O. 159

Parks, D. 207  
Pastalan, L. 90, 97  
Pauls, J. 108  
Pavlov, I. 236  
Payne, I. 181  
Payne, S. 261  
Pearson, K. 137  
Perin, C. 76  
Peterson, G. 75  
Porteous, C. 116, 117  
Porteous, J. 116, 117  
Proshansky, H. 30, 75, 251

Rademacher 132  
Rapoport, A. 83, 84, 85, 86, 90, 92,  
246

Redding, M. 75  
Reed, J. 206  
Reed, P. 26, 27  
Reiher, H. 203  
Reimer, S. 221, 250  
Ribiero, J. 155, 156  
Rivlin, L. 30, 75, 251  
Roberts 84, 246  
Robertson, C. 204  
Roebuck, J. 270  
Roethlisberger, F. 249  
Rohles, F. 188, 189  
Roizen, R. 115  
Rosenzweig, S. 247  
Rubin, A. 25, 106  
Rubin, E. 149  
Russo, N. 86, 87

Saltzman, M. 172  
Sanoff, H. 114  
Sasanoff, R. 111  
Savinar, J. 118  
Shlisser, D. 146  
Schmitz, M. 209  
Schroder 244  
Schultz, T. 136  
Seaton, R. 62  
Sechenov, M. 236  
Sheridan, J. 105  
Shils, E. 59  
Siegel, A. 217  
Skinner, B. 40, 263  
Sleight, R. 213  
Smith, S. 162  
Snyder, F. 207  
Sommer, R. 10, 87, 114, 122  
Southworth, M. 73  
Sperling, E. 207  
Springer, K. 202  
Steinfeld, E. 90  
Stevens, S. 55, 137, 216, 239  
Stiles 165  
Stilitz, I. 111  
Stokols, D. 90  
Stone, P. 159  
Stroud, H. 92  
Suchman, E. 109, 261  
Swallow, J. 206

Taylor, F. 100  
Thiel, P. 61  
Thompson, M. 270  
Tindall, M. 87  
Turk, A. 200, 202

Vance, B. 217  
Van Cott, H. 26, 58, 134, 219  
Van Deusen 208  
Venze 132  
Verillo 216  
Vigier, F. 114  
von Frey, M. 216

Wachsler, R. 103  
Ward, J. 102  
Ware, T. 27  
Watson, N. 83, 84, 85, 92  
Webb, E. 64, 65  
Weber, E. 237  
Wells, B. 89  
Wertheimer, M. 148, 149, 150, 243  
Weisz, A. 207  
Weston, M. 161, 162  
Williamson, P. 88  
Wilson, E. 51, 263, 264, 270  
Wilson, R. 74  
Winkel, G. 61, 111  
Wittes, J. 200  
Worrall, R. 75  
Wright, J. 6, 28  
Wright, W. 241  
Wundt, W. 237, 244  
Wyon, D. 191, 192, 195  
Wyszecki, G. 167, 168, 173

Yagloglou, C. 186, 187  
Yamada, M. 204, 205, 209  
Yaniv, S. 130, 131  
Yarbus, A. 146, 147  
Yonemura, G. 156, 163, 164  
Yoshida, M. 218  
Youden, W. 271  
Young, T. 240

Zwaardemaker 200



U.S. DEPT. OF COMM. BIBLIOGRAPHIC DATA SHEET	1. PUBLICATION OR REPORT NO.  NBS SP 474	2. Gov't. Accession No.	3. Recipient's Accession No.
4. TITLE AND SUBTITLE  Building for People -- Behavioral Research Approaches and Directions			
5. Publication Date  June 1980			
6. Performing Organization Code			
7. AUTHOR(S)  Arthur I. Rubin and Jacqueline Elder			
8. Performing Organ. Report No.			
9. PERFORMING ORGANIZATION NAME AND ADDRESS  NATIONAL BUREAU OF STANDARDS DEPARTMENT OF COMMERCE WASHINGTON, DC 20234			
10. Project/Task/Work Unit No.			
11. Contract/Grant No.			
12. SPONSORING ORGANIZATION NAME AND COMPLETE ADDRESS (Street, City, State, ZIP)  Same as item 9.			
13. Type of Report & Period Covered  Final			
14. Sponsoring Agency Code			
15. SUPPLEMENTARY NOTES  Library of Congress Catalog Card Number: 80-600065 <input type="checkbox"/> Document describes a computer program; SF-185, FIPS Software Summary, is attached.			
16. ABSTRACT (A 200-word or less factual summary of most significant information. If document includes a significant bibliography or literature survey, mention it here.)  The primary goal of this report is to acquaint the practicing architect and the architectural student with the potential contributions of the social sciences to the solution of building design problems. The report is divided into seven major parts, each part containing several chapters. Part I explores problems connected with today's buildings and advocates a design approach based on a team concept including architects, behavioral researchers, and engineers. Part II takes up the scientific approach to research, stressing the need for employing experimental controls and systematic procedures to collect objective data. Parts III, IV, and V describe methods employed by researchers to collect Man/Environment (M/E) data. The emphasis is on the need to develop systematic procedures to collect information, because only in this way can significant progress be made in developing a discipline of M/E studies. Part VI summarizes the major points and indicates approaches and directions for developing such a discipline. Part VII contains reference information to broaden the perspective of the reader with respect to M/E issues. The final part of the work contains a glossary, bibliographic information, and an index.			
17. KEY WORDS (six to twelve entries; alphabetical order; capitalize only the first letter of the first key word unless a proper name; separated by semicolons)  Architecture; audition; built environment; color; environmental psychology; illumination; perception; questionnaires; research methodology; sensory environment; social sciences; thermal environment.			
18. AVAILABILITY  <input checked="" type="checkbox"/> Unlimited  <input type="checkbox"/> For Official Distribution. Do Not Release to NTIS		19. SECURITY CLASS (THIS REPORT)  UNCLASSIFIED	
20. SECURITY CLASS (THIS PAGE)  UNCLASSIFIED		21. NO. OF PRINTED PAGES  315	
22. Price  \$14.			













